



Installation and commissioning instructions VACUTAP® VM®. On-load tap-changer

4338382/03 EN



© All rights reserved by Maschinenfabrik Reinhausen
Dissemination and reproduction of this document and use and disclosure of its content are strictly prohibited unless expressly permitted.
Infringements will result in liability for compensation. All rights reserved in the event of the granting of patents, utility models or designs.
The product may have been altered since this document was published.
We reserve the right to change the technical data, design and scope of supply.
Generally the information provided and agreements made when processing the individual quotations and orders are binding.
The original operating instructions were written in German.

Table of contents

1 Introduction	5	5.2 Installing the on-load tap-changer in the transformer (standard version)	32
1.1 Manufacturer	5	5.2.1 Fastening on-load tap-changer to transformer cover	32
1.2 Completeness	5	5.2.2 Connecting the tap winding and on-load tap-changer take-off lead	36
1.3 Safekeeping	5	5.2.3 Performing transformer ratio test before drying	43
1.4 Notation conventions	5	5.2.4 Performing DC resistance measurement on transformer	43
1.4.1 Hazard communication system	5	5.2.5 Drying on-load tap-changer in autoclave.....	44
1.4.2 Information system	6	5.2.6 Drying on-load tap-changer in transformer tank	50
1.4.3 Instruction system.....	6	5.2.7 Filling the oil compartment of the on-load tap-changer with insulating fluid.....	63
2 Safety	8	5.2.8 Performing transformer ratio test after drying	65
2.1 Appropriate use	8	5.3 Installing on-load tap-changer in transformer (bell-type tank version)	66
2.2 Inappropriate use	9	5.3.1 Inserting on-load tap-changer into supporting structure	66
2.3 Fundamental safety instructions	9	5.3.2 Connecting the tap winding and on-load tap-changer take-off lead	69
2.4 Personnel qualification	10	5.3.3 Performing transformer ratio test before drying	76
2.5 Personal protective equipment.....	11	5.3.4 Performing DC resistance measurement on transformer	76
3 Product description	12	5.3.5 Drying on-load tap-changer in autoclave.....	77
3.1 Scope of delivery.....	12	5.3.6 Lifting top part of on-load tap-changer head off supporting flange (bottom part)	83
3.2 On-load tap-changer	12	5.3.7 Attaching the bell-type tank and connecting the on-load tap-changer to the top part of the on-load tap-changer head.....	90
3.2.1 Function description.....	12	5.3.8 Drying on-load tap-changer in transformer tank	101
3.2.2 Setup/models	13	5.3.9 Filling the oil compartment of the on-load tap-changer with insulating fluid.....	115
3.2.3 Nameplate and serial number.....	15	5.3.10 Performing transformer ratio test after drying	117
3.2.4 Protective devices	16		
3.3 Drive shaft	22		
3.3.1 Function description.....	22		
3.3.2 Design/versions.....	22		
4 Packaging, transport and storage	27		
4.1 Packaging	27		
4.1.1 Suitability	27		
4.1.2 Markings	27		
4.2 Transportation, receipt and handling of shipments	28		
4.3 Storage of shipments	29		
4.4 Unpacking shipments and checking for transportation damages	29		
5 Mounting	30		
5.1 Preparatory work	30		
5.1.1 Fitting mounting flange on transformer cover.....	30		
5.1.2 Fitting stud bolts on mounting flange	31		

5.4 Fitting protective devices and drive components.....	118	8.2 Technical data for protective relay	201
5.4.1 Electrically connecting the temperature sensor.....	118	8.3 Special models of protective relay	203
5.4.2 Connecting the tap-change supervisory device	118	8.3.1 Protective relay with CO change-over contact as tripping switch	203
5.4.3 Installing protective relay in piping and connecting	118	8.3.2 Protective relay with several dry-reed magnetic switches	203
5.4.4 Installing and connecting the pressure monitoring device	128	8.4 Technical data for pressure monitoring device	204
5.4.5 Fitting motor-drive unit	131	8.5 Limit values for dielectric strength and water content of insulating fluids.....	205
5.4.6 Fitting drive shaft.....	131	8.6 On-load tap-changer for Y connection with open neutral point.....	206
5.4.7 Centering on-load tap-changer and motor-drive unit	179	9 Drawings	207
5.4.8 Making the electrical connections for the motor-drive unit	179	9.1 746230	208
6 Commissioning.....	180	9.2 890477	210
6.1 Commissioning the on-load tap-changer at the transformer manufacturer's site	180	9.3 896762.....	211
6.1.1 Bleeding on-load tap-changer head and suction pipe	180	9.4 890180	212
6.1.2 Grounding the on-load tap-changer.....	182	9.5 893899.....	213
6.1.3 Checking motor-drive unit.....	183	9.6 766161	214
6.1.4 High-voltage tests on the transformer	183	9.7 890183.....	215
6.2 Transporting transformer to the operating site	185	9.8 890182.....	216
6.2.1 Transport with drive removed.....	185	9.9 892916.....	217
6.2.2 Transport with full transformer tank and without oil conservator.....	185		
6.2.3 Transport with empty transformer tank	186		
6.3 Commissioning transformer at operating site	187		
6.3.1 Filling the oil compartment of the on-load tap-changer with insulating fluid.....	187		
6.3.2 Bleeding on-load tap-changer head and suction pipe	188		
6.3.3 Checking motor-drive unit	189		
6.3.4 Checking protective relay.....	190		
6.3.5 Checking pressure monitoring device.....	191		
6.3.6 Commissioning the transformer	191		
7 Fault elimination	192		
7.1 Tripping the protective relay and re-commissioning the transformer	194		
7.1.1 Flap valve in OPERATION position	194		
7.1.2 Flap valve in OFF position.....	195		
7.1.3 Re-commissioning the transformer.....	195		
7.2 Tripping the pressure monitoring device and putting the transformer back into operation.....	196		
7.2.1 Sensor in the OPERATION position.....	196		
7.2.2 Sensor in the OFF position	196		
7.2.3 Re-commissioning the transformer	196		
8 Technical data	197		
8.1 Technical data for on-load tap-changer	197		
8.1.1 On-load tap-changer properties.....	197		
8.1.2 Permissible ambient conditions.....	198		
8.1.3 Height of the oil conservator.....	199		
8.1.4 Installation height above sea level.....	199		

1 Introduction

This technical file contains detailed descriptions of the safe and proper installation, connection, and commissioning of the product.

It also includes safety instructions and general information about the product.

Information about operation can be found in the operating instructions.

This technical file is intended solely for specially trained and authorized personnel.

1.1 Manufacturer

Maschinenfabrik Reinhausen GmbH
Falkensteinstrasse 8
93059 Regensburg
Germany

Tel.: +49 941 4090-0
E-mail: sales@reinhausen.com
Internet: www.reinhausen.com
MR Reinhausen customer portal: <https://portal.reinhausen.com>

Further information on the product and copies of this technical file are available from this address if required.

1.2 Completeness

This technical file is incomplete without the supporting documents.

The following documents are considered supporting documents:

- Unpacking instructions
- Supplement
- Routine test report
- Connection diagrams
- Dimensional drawings
- Order confirmation

1.3 Safekeeping

Keep this technical file and all supporting documents ready at hand and accessible for future use at all times.

1.4 Notation conventions

1.4.1 Hazard communication system

Warnings in this technical file are displayed as follows.

1.4.1.1 Warning relating to section

Warnings relating to sections refer to entire chapters or sections, sub-sections or several paragraphs within this technical file. Warnings relating to sections use the following format:

▲ WARNING



Type of danger!

Source of the danger and outcome.

- > Action
- > Action

1.4.1.2 Embedded warning information

Embedded warnings refer to a particular part within a section. These warnings apply to smaller units of information than the warnings relating to sections. Embedded warnings use the following format:

▲ DANGER! Instruction for avoiding a dangerous situation.

1.4.1.3 Signal words in warning notices

Signal word	Meaning
DANGER	Indicates a hazardous situation which, if not avoided, will result in death or serious injury.
WARNING	Indicates a hazardous situation which, if not avoided, could result in death or serious injury.
CAUTION	Indicates a hazardous situation which, if not avoided, could result in minor or moderate injury.
NOTICE	Indicates measures to be taken to prevent damage to property.

Table 1: Signal words in warning notices

1.4.2 Information system

Information is designed to simplify and improve understanding of particular procedures. In this technical file it is laid out as follows:



Important information.

1.4.3 Instruction system

This technical file contains single-step and multi-step instructions.

Single-step instructions

Instructions which consist of only a single process step are structured as follows:

Aim of action

- ✓ Requirements (optional).
- > Step 1 of 1.
 - » Result of step (optional).
 - » Result of action (optional).

Multi-step instructions

Instructions which consist of several process steps are structured as follows:

Aim of action

✓ Requirements (optional).

1. Step 1.

» Result of step (optional).

2. Step 2.

» Result of step (optional).

» Result of action (optional).

2 Safety

- Read this technical file through to familiarize yourself with the product.
- This technical file is a part of the product.
- Read and observe the safety instructions provided in this chapter.
- Read and observe the warnings in this technical file in order to avoid function-related dangers.
- The product is manufactured on the basis of state-of-the-art technology. Nevertheless, risks to life and limb for the user or impairment of the product and other material assets due to the function may arise in the event of improper use.

2.1 Appropriate use

The product is an on-load tap-changer and adjusts the transmission ratio of transformers without interrupting the load flow. The product is designed solely for use in electrical energy systems and facilities. If used as intended and in compliance with the requirements and conditions specified in this technical file as well as the warning notices in this technical file and attached to the product, then the product does not present any danger to people, property or the environment. This applies throughout the service life of the product, from delivery, installation and operation to removal and disposal.

The following is considered appropriate use:

- Use the product only with the transformer/motor-drive unit specified in the order.
- The serial numbers of on-load tap-changer and on-load tap-changer accessories (drive, drive shaft, bevel gear, protective relay, etc.) must match if the on-load tap-changer and on-load tap-changer accessories are supplied as a set for one order.
- You will find the standard valid for the product and the year of issue on the nameplate.
- Operate the product in accordance with this provided technical file, the agreed delivery conditions and technical data.
- Ensure that all necessary work is performed by qualified personnel only.
- Only use the equipment and special tools included in the scope of delivery for the intended purpose and in accordance with the specifications of this technical file.
- The on-load tap-changer is not intended to be used with an oil filter unit.

Permitted electrical operating conditions

In addition to the design data in accordance with the order confirmation, observe the following limits for the through-current and the step voltage:

In the standard version, the on-load tap-changer is designed for sinusoidal 50/60 Hz alternating current with a curve form symmetrical to the zero axis and can switch 2 times the rated through-current I_r at its rated step voltage U_{ir} .

Exceeding the rated step voltage U_{ir} by up to 10% for a short period is permitted as long as the rated step capacity P_{STN} permissible for this step voltage is not exceeded.

2.2 Inappropriate use

Use is considered inappropriate if the product is used in a way other than as described in the "Appropriate use" section. In addition, observe the following:

Prohibited electrical operating conditions

All operating conditions that do not comply with the design data in accordance with the order confirmation are prohibited.

Prohibited operating conditions may arise due to short circuits as well as due to inrush current impulses when energizing transformers or other electrical machines. This applies to the affected transformer itself just as it does to transformers electrically connected in parallel or serially or other electrical machines.

Higher voltages may occur due to transformer overexcitation following load shedding, for example.

Operations outside of the permitted operating conditions can lead to injury to persons and damage to the product.

- Prevent any such operations outside of the permitted operating conditions by taking suitable measures.

2.3 Fundamental safety instructions

To prevent accidents, disruptions and damage as well as unacceptable adverse effects on the environment, those responsible for transport, installation, operation, maintenance and disposal of the product or parts of the product must ensure the following:

Personal protective equipment

Loosely worn or unsuitable clothing increases the danger of becoming trapped or caught up in rotating parts and the danger of getting caught on protruding parts. This poses a danger to life and limb.

- Wear appropriate personal protective equipment such as a helmet, work gloves, etc. for the respective activity.
- Never wear damaged personal protective equipment.
- Never wear rings, necklaces, or other jewelry.
- If you have long hair, wear a hairnet.

Work area

Untidy and poorly lit work areas can lead to accidents.

- Keep the work area clean and tidy.
- Make sure that the work area is well lit.
- Observe the applicable laws for accident prevention in the relevant country.

Working during operation

The product may only be operated in a sound, operational condition. Otherwise it poses a danger to life and limb.

- Regularly check the operational reliability of safety equipment.
- Comply with the inspection work, maintenance work and maintenance intervals described in this technical file.

Explosion protection

Highly flammable or explosive gases, vapors and dusts can cause serious explosions and fire. This increases the danger to life and limb.

- Do not install, operate or perform maintenance work on the product in areas where a risk of explosion is present.

Safety markings

Warning signs and safety information plates are safety markings on the product. They are an important aspect of the safety concept.

- Observe all safety markings on the product.
- Make sure all safety markings on the product remain intact and legible.
- Replace safety markings that are damaged or missing.

Ambient conditions

To ensure reliable and safe operation, the product must only be operated under the ambient conditions specified in the technical data.

- Observe the specified operating conditions and requirements for the installation location.

Auxiliary materials and operating materials

Auxiliary materials and operating materials not approved by the manufacturer can lead to personal injury, damage to property and malfunctions of the product.

- Only use insulating fluids [► Section 8.1.2, Page 198] approved by the manufacturer.
- Only use conductive and grounded hoses, pipes and pump equipment that are approved for flammable liquids.
- Only use lubricants and auxiliary materials approved by the manufacturer.
- Contact the manufacturer.

Modifications and conversions

Unauthorized or inappropriate changes to the product may lead to personal injury, material damage and operational faults.

- Only modify the product after consultation with Maschinenfabrik Reinhausen GmbH.

Spare parts

Spare parts not approved by Maschinenfabrik Reinhausen GmbH may lead to physical injury, damage to the product and malfunctions.

- Only use spare parts that have been approved by Maschinenfabrik Reinhausen GmbH.
- Contact Maschinenfabrik Reinhausen GmbH.

2.4 Personnel qualification

The person responsible for assembly, commissioning, operation, maintenance and inspection must ensure that the personnel are sufficiently qualified.

Electrically skilled person

The electrically skilled person has a technical qualification and therefore has the required knowledge and experience, and is also conversant with the applicable standards and regulations. The electrically skilled person is also proficient in the following:

- Can identify potential dangers independently and is able to avoid them.
- Is able to perform work on electrical systems.

- Is specially trained for the working environment in which (s)he works.
- Must satisfy the requirements of the applicable statutory regulations for accident prevention.

Electrically trained persons

An electrically trained person receives instruction and guidance from an electrically skilled person in relation to the tasks undertaken and the potential dangers in the event of inappropriate handling as well as the protective devices and safety measures. The electrically trained person works exclusively under the guidance and supervision of an electrically skilled person.

Operator

The operator uses and operates the product in line with this technical file. The operating company provides the operator with instruction and training on the specific tasks and the associated potential dangers arising from improper handling.

Technical Service

We strongly recommend having maintenance, repairs and retrofitting carried out by our Technical Service department. This ensures that all work is performed correctly. If maintenance is not carried out by our Technical Service department, please ensure that the personnel who carry out the maintenance are trained and authorized by Maschinenfabrik Reinhausen GmbH to carry out the work.

Authorized personnel

Authorized personnel are trained by Maschinenfabrik Reinhausen GmbH to carry out special maintenance.

2.5 Personal protective equipment

Personal protective equipment must be worn during work to minimize risks to health.

- Always wear the personal protective equipment required for the job at hand.
- Never wear damaged personal protective equipment.
- Observe information about personal protective equipment provided in the work area.

Protective clothing	Close-fitting work clothing with a low tearing strength, with tight sleeves and with no protruding parts. It mainly serves to protect the wearer against being caught by moving machine parts.
Safety shoes	To protect against falling heavy objects and slipping on slippery surfaces.
Safety glasses	To protect the eyes from flying parts and splashing liquids.
Visor	To protect the face from flying parts and splashing liquids or other dangerous substances.
Hard hat	To protect against falling and flying parts and materials.
Hearing protection	To protect against hearing damage.
Protective gloves	To protect against mechanical, thermal, and electrical hazards.

Table 2: Personal protective equipment

3 Product description

3.1 Scope of delivery

The product is packaged with protection against moisture and is usually delivered as follows:

- Diverter switch (oil compartment with diverter switch insert)
- Selector
- Motor-drive unit
- Drive shaft with coupling parts and bevel gear

- Protective devices
- Technical files

Please refer to the delivery slip for full details of the scope of delivery.



On-load tap-changers can also be provided as an on-load tap-changer set with a common motor-drive unit.

Note the following information:

- Check the shipment for completeness on the basis of the shipping documents.
- Store the parts in a dry place until installation
- The product must remain in its airtight, protective wrapping and may only be removed immediately before installation

You will find more information in the "Packaging, transport, and storage" [► Section 4, Page 27] chapter.

3.2 On-load tap-changer

3.2.1 Function description

On-load tap-changers are used to adjust the transmission ratio of transformers without interrupting the load flow. This makes it possible to compensate for aspects such as fluctuations in voltage occurring in the power transmission grid. For this purpose, on-load tap-changers are fitted in transformers and connected to the active part of the transformer.

A motor-drive unit which receives a control impulse (e.g. from a voltage regulator) changes the operating position of the on-load tap-changer, as a result of which the transformer's transmission ratio is adapted to the prevailing operating requirements.

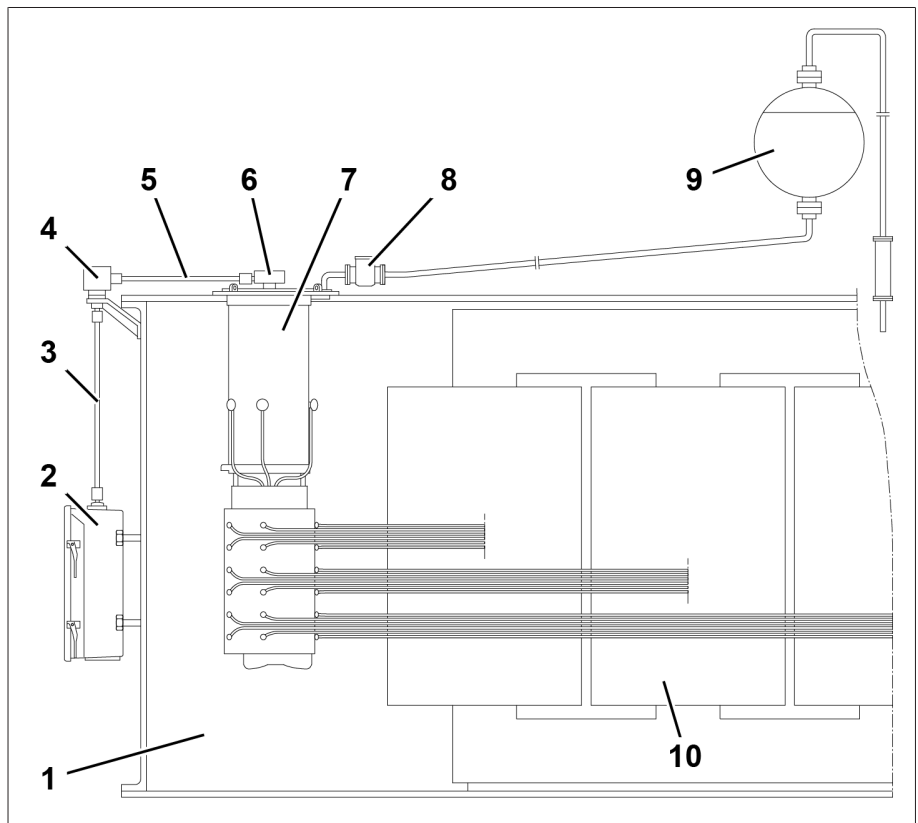

Figure 1: System overview of on-load tap-changer, transformer

1	Transformer tank	6	Upper gear unit
2	Motor-drive unit	7	On-load tap-changer
3	Vertical drive shaft	8	Protective relay
4	Bevel gear	9	Oil conservator
5	Horizontal drive shaft	10	Active part of the transformer

3.2.2 Setup/models

The following drawing shows the main components of the on-load tap-changer.

You will find a detailed drawing of the on-load tap-changer in the "Drawings [▶ Section 9, Page 207]" section.

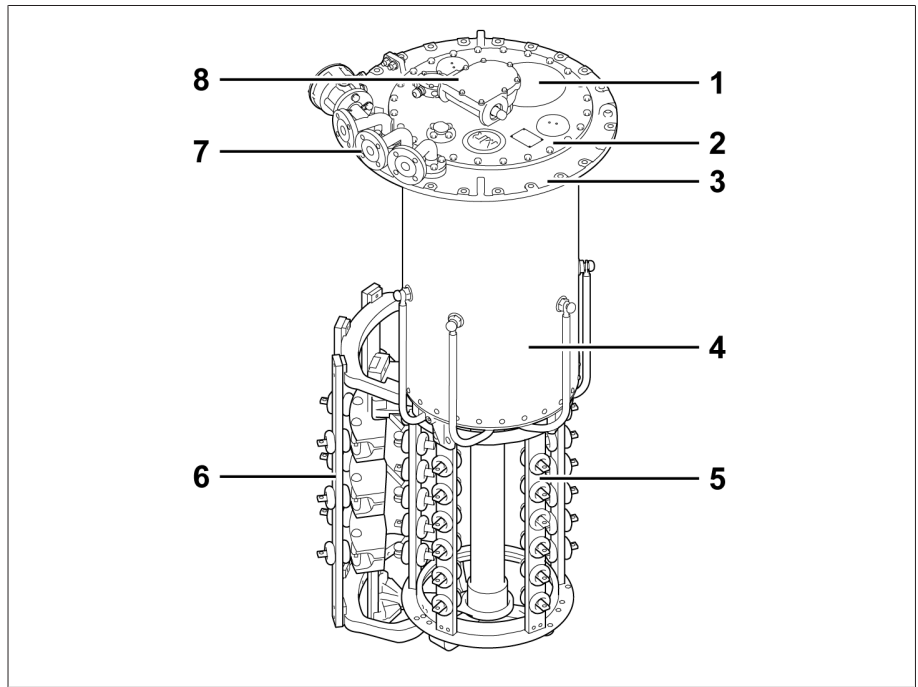

Figure 2: On-load tap-changer

1	Rupture disk	2	On-load tap-changer head cover
3	On-load tap-changer head	4	Oil compartment
5	Selector	6	Change-over selector
7	Pipe bend	8	Upper gear unit

3.2.2.1 Pipe connections

The on-load tap-changer head features 4 pipe connections for different purposes.

Depending on the order, some or all of these pipe connections are fitted with pipe bends ex factory. All pipe bends without terminal box for the tap-change supervisory control can be freely swiveled once the pressure ring is loosened.

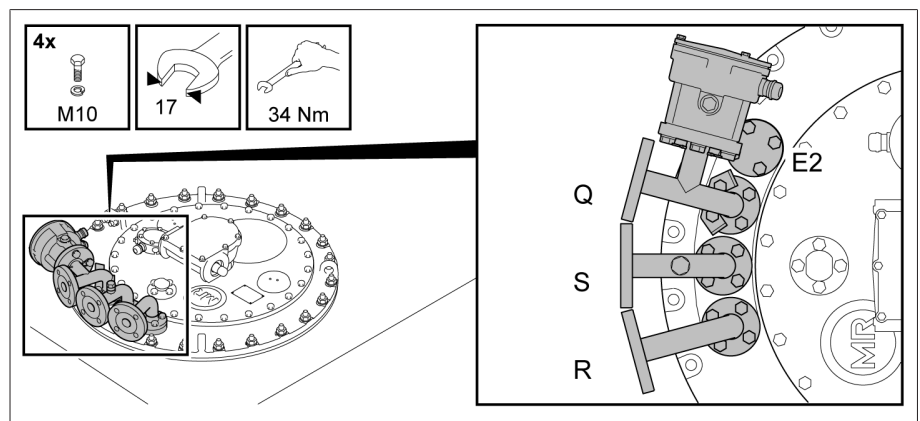

Figure 3: Pipe connections with pipe bends

Pipe connection Q

The pipe connection Q is closed with a blank cover. If the on-load tap-changer is equipped with a tap-change supervisory device, the connection cables for the tap-change supervisory device are fed through the pipe connection.



The functions of the R and Q pipe connections can be interchanged.

Pipe connection S

The pipe bend on pipe connection S features a vent screw and can be connected to a pipe that ends with a drain valve on the side of the transformer tank at operating height. If the on-load tap-changer is fitted with an oil suction pipe, the on-load tap-changer can be completely emptied via pipe connection S.

Pipe connection R

Pipe connection R is intended for attachment of the protective relay and connection of the on-load tap-changer oil conservator and can be interchanged with pipe connection Q.

Pipe connection E2

Pipe connection E2 is sealed off with a blank cover. It leads into the oil tank of the transformer, directly under the on-load tap-changer head and can be connected to a collective pipe for the Buchholz relay, if necessary. This pipe connection serves a further purpose, namely to equalize the pressure between the transformer tank and oil compartment of the on-load tap-changer, which is necessary for drying, filling with insulating fluid and transportation of the transformer.

3.2.3 Nameplate and serial number

The nameplate with serial number is on the on-load tap-changer head cover.

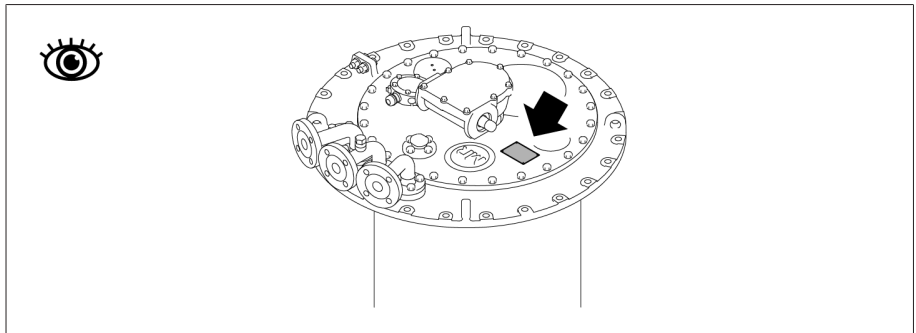

Figure 4: Nameplate

The serial number can also be found on the selector.

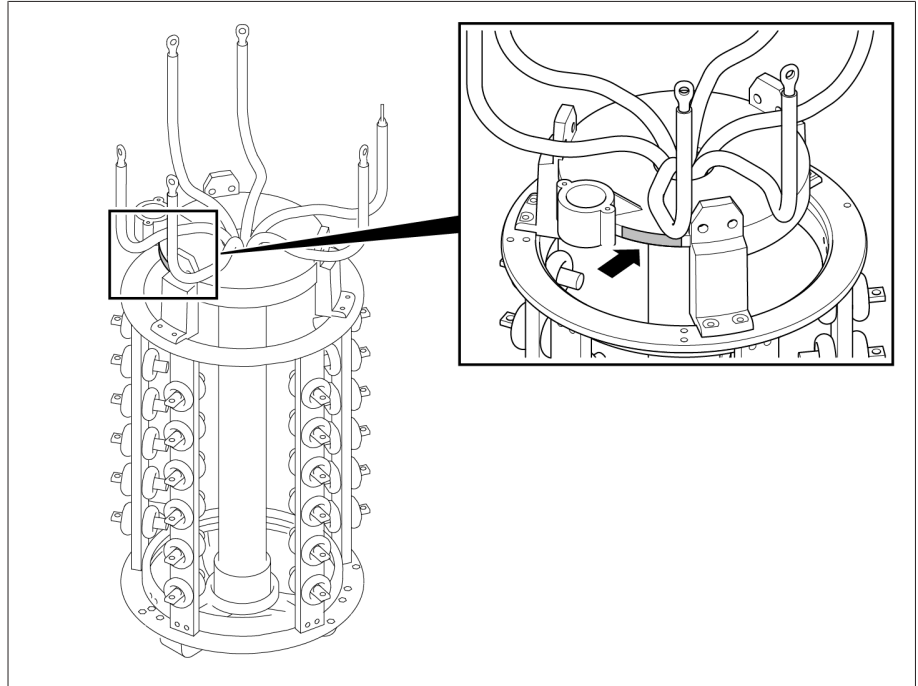

Figure 5: Serial number

3.2.4 Protective devices

The on-load tap-changer is equipped with the following protective devices.

3.2.4.1 Protective relay

3.2.4.1.1 Function description

The protective relay is looped into the circuit breaker tripping circuit. It is tripped when the specified speed of flow from the on-load tap-changer head to the oil conservator is exceeded due to a fault. The flowing insulating fluid actuates the flap valve which tips over into position OFF. The contact in the dry-reed magnetic switch is thereby actuated, the circuit breakers are tripped, and the transformer is de-energized.

The protective relay is a component of an on-load tap-changer filled with insulating fluid and its properties conform to the respective applicable version of IEC publication 60214-1.

- Diverter switch operations at rated switching capacity or at permissible overload will not cause the protective relay to trip.

- The protective relay responds to flow, not to gas accumulated in the protective relay. It is not necessary to bleed the protective relay when filling the transformer with insulating fluid. Gas accumulation in the protective relay is normal.

3.2.4.1.2 Design/versions

Front view

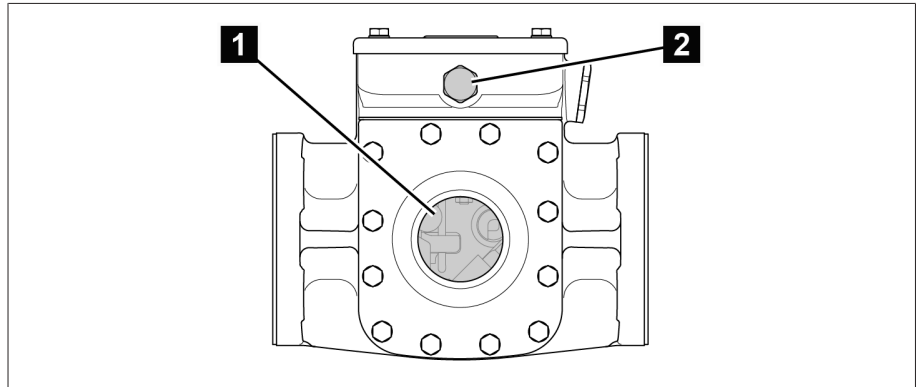

Figure 6: Protective relay RS 2001

1	Inspection window	2	Pressure equalization element
---	-------------------	---	-------------------------------

Rear view

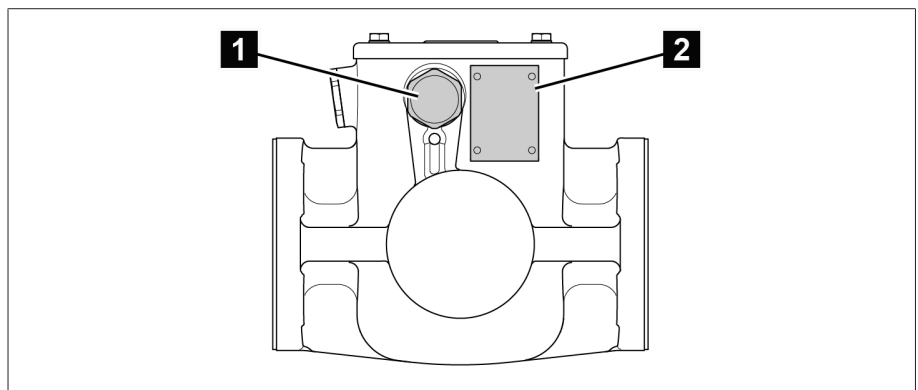

Figure 7: Protective relay RS 2001

1	Dummy plug	2	Nameplate
---	------------	---	-----------

• The protective relay RS 2001/R has an extra inspection window on the rear.

View from above

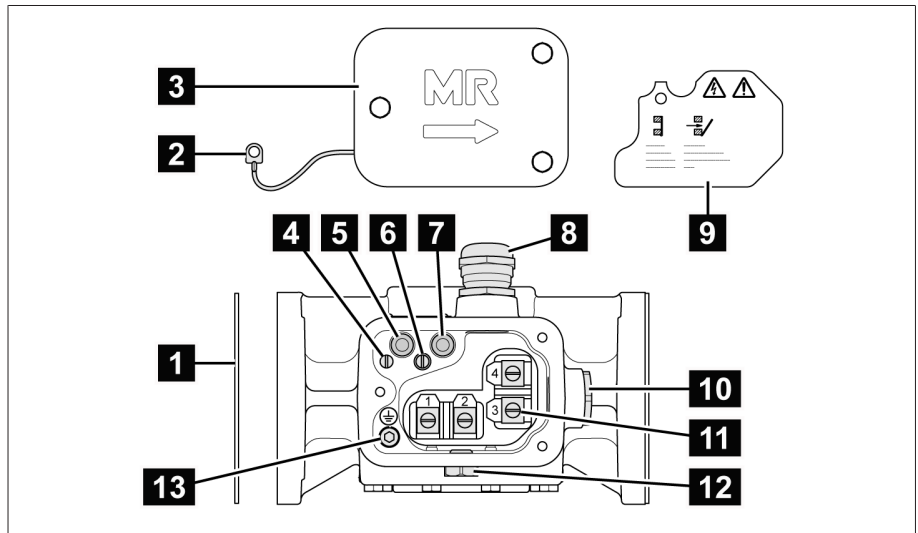

Figure 8: Protective relay RS 2001

1	Gasket	2	Potential tie-in
3	Terminal box cover	4	Slotted head screw for potential tie-in
5	OPERATION (reset) test button	6	Slotted head screw for protective cover
7	OFF (test tripping) test button	8	Cable gland
9	Protective cover	10	Dummy plug
11	Connection terminal	12	Pressure equalization element
13	Cylinder head screw for protective conductor connection		



The protective relays RS 2003 and RS 2004 have a 1/2"-14NPT adapter in place of the cable gland.

3.2.4.1.3 Nameplate

The nameplate is on the back of the protective relay.

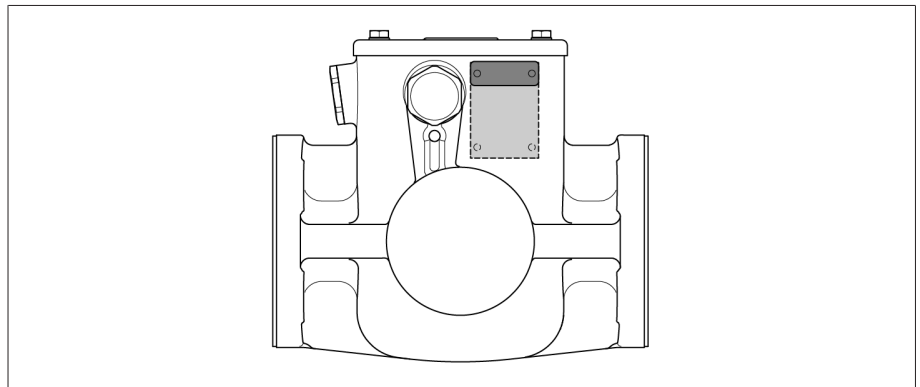

Figure 9: Nameplate

3.2.4.1.4 Safety markings

The following safety markings are used on the product:

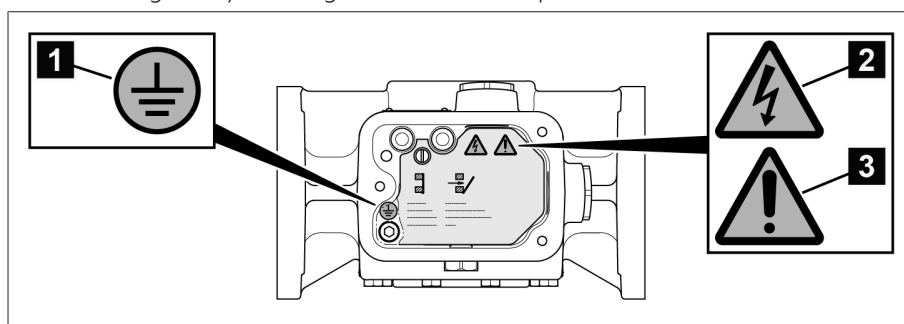

Figure 10: Safety markings overview

1	Protective conductor connection	2	Warning of dangerous electrical voltage
3	Read the documentation		

3.2.4.2 Pressure monitoring device DW

3.2.4.2.1 Function description

The DW 2000 pressure monitoring device protects the on-load tap-changer from impermissible pressure increases, contributing to the safety of the transformer. The pressure monitoring device is installed on the outside of the on-load tap-changer and is tripped by impermissible static and dynamic pressures in the on-load tap-changer oil compartment.

The pressure monitoring device uses a concept where a corrugated tube acts as a barometer together with a spring providing counter force. This assembly is mechanically linked to the sensor on the snap-action switch.

The pressure increase activates the sensor on the snap-action switch, which flips into the OFF position. This triggers the circuit breaker and de-energizes the transformer. The sensor on the snap-action switch has to be reset to the initial position by hand after tripping.

Low-energy interference does not cause the pressure monitoring device to trip since the required tripping pressure is not reached. The tripping pressure is set at the factory and prevented from being changed.

The pressure monitoring device responds to large pressure increases faster than the protective relay. The protective relay is part of the standard MR protection system and comes as standard.

- Additional use of a pressure monitoring device also requires installation of the provided protective relay.

The features and characteristics of the pressure monitoring device comply with the respective applicable version of IEC publication 60214-1.

- Diverter switch operations at the rated switching capacity or permitted overload do not cause the pressure-operated relay to trip.



The pressure-operated relay responds to a pressure change and not to gas accumulation under the pressure-operated relay. Gas accumulation under the pressure-operated relay is normal.

3.2.4.2.2 Design/versions

There are two variants of the pressure monitoring device:

- DW 2000 for vertical installation
- DW 2000 for horizontal installation

The housing and the cover cap of the pressure monitoring device consist of lightweight, corrosion-resistant metal.

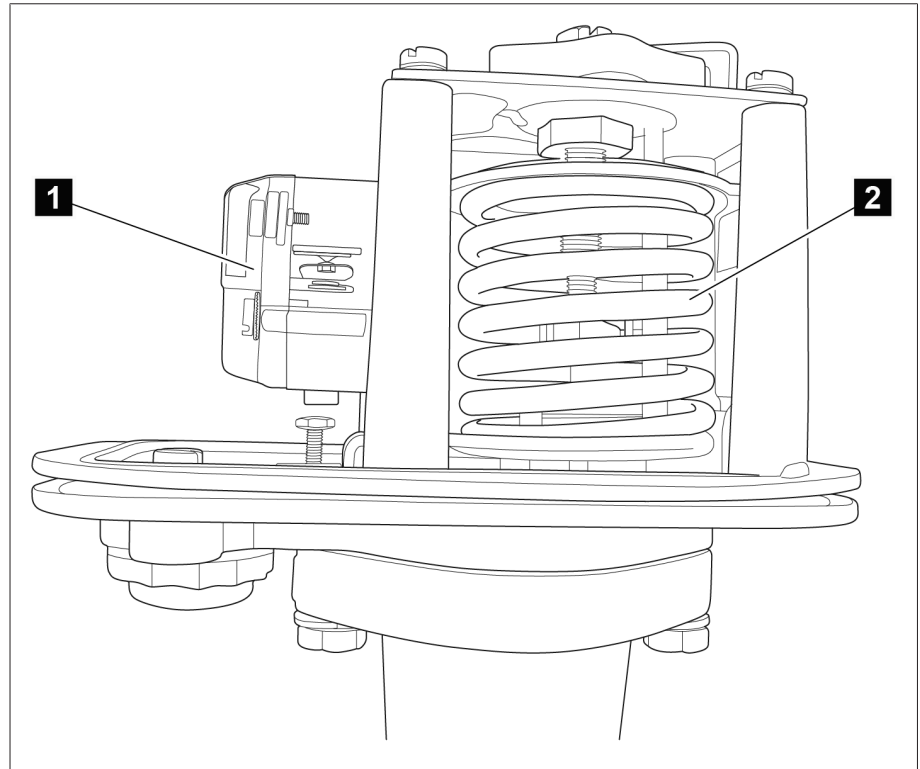

Figure 11: Snap-action switch and pressure measuring element

1	Snap-action switch	2	Pressure measuring element
---	--------------------	---	----------------------------

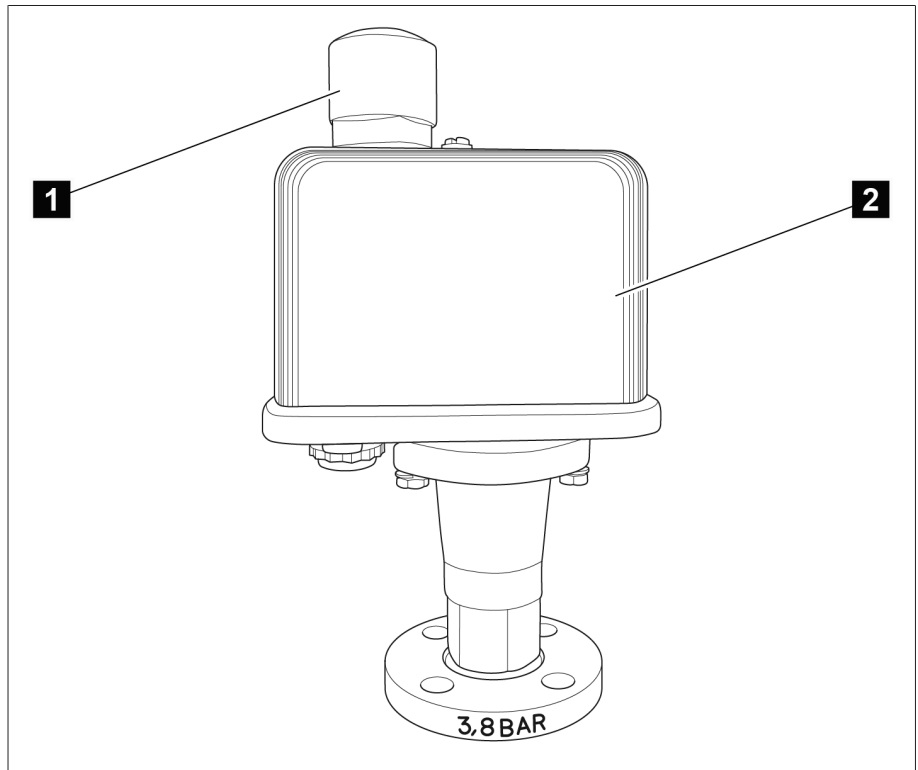

Figure 12: Pressure monitoring device with cover cap and ventilation

1	Ventilation	2	Cover cap
---	-------------	---	-----------

3.2.4.3 Rupture disk

The rupture disk is a pressure relief device without signaling contact in accordance with IEC 60214-1 and is located in the on-load tap-changer head cover.

The rupture disk responds to a defined overpressure in the oil compartment of the on-load tap-changer.

3.2.4.4 Pressure relief device MPREC®

On request, MR will supply a pre-fitted MPREC® pressure relief device in place of the rupture disk. This device responds to a defined overpressure in the oil compartment of the on-load tap-changer.

The on-load tap-changer therefore meets the requirements of IEC 60214-1 regarding pressure relief devices.

3.2.4.5 Tap-change supervisory device

The tap-change supervisory device monitors both the drive shaft between on-load tap-changer(s) and motor-drive unit and the correct switching of the diverter switch.

3.2.4.6 Temperature monitoring

The temperature monitoring system monitors the temperature of the insulating fluid in the oil compartment of the on-load tap-changer.

3.3 Drive shaft

3.3.1 Function description

The drive shaft is the mechanical connection between the drive and the on-load tap-changer/de-energized tap-changer.

The bevel gear changes the direction from vertical to horizontal.

Accordingly, the vertical drive shaft has to be mounted between drive and bevel gear, and the horizontal drive shaft between bevel gear and on-load tap-changer or de-energized tap-changer.

3.3.2 Design/versions

The drive shaft consists of a square tube and is coupled at each end by two coupling brackets and one coupling bolt to the driving or driven shaft end of the device to be connected.

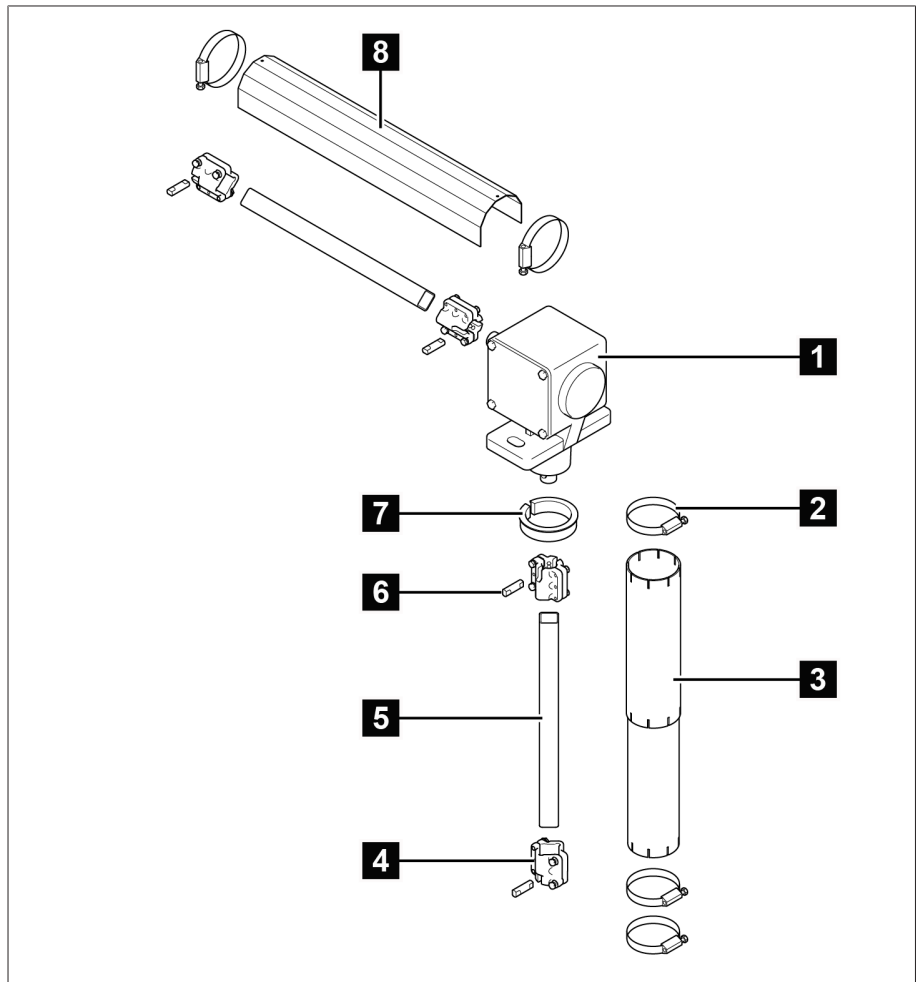

Figure 13: Components of the drive shaft

1	Bevel gear	2	Hose clip
3	Telescopic protective tube	4	Coupling bracket
5	Square tube	6	Coupling bolt
7	Adapter ring	8	Protective cover

3.3.2.1 Drive shaft without cardan joint and without insulator

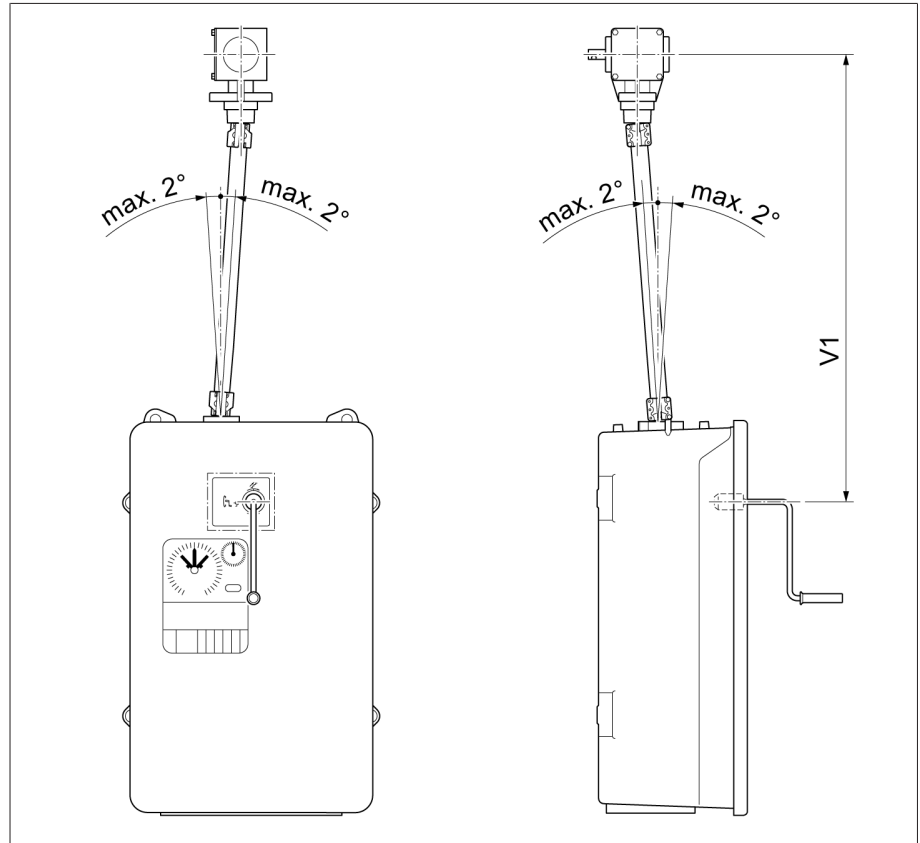

Figure 14: Drive shaft without cardan joint and without insulator (= standard version)

Configuration	V 1 min	Intermediate bearing
Middle of hand crank – middle of bevel gear (maximum permissible axial offset 2°)	536 mm	When the maximum value of 2472 mm is exceeded, it is necessary to use an intermediate bearing. $V 1 \leq 2472$ mm (without intermediate bearing) $V 1 > 2472$ mm (with intermediate bearing)

3.3.2.2 Drive shaft without cardan joint and with insulator

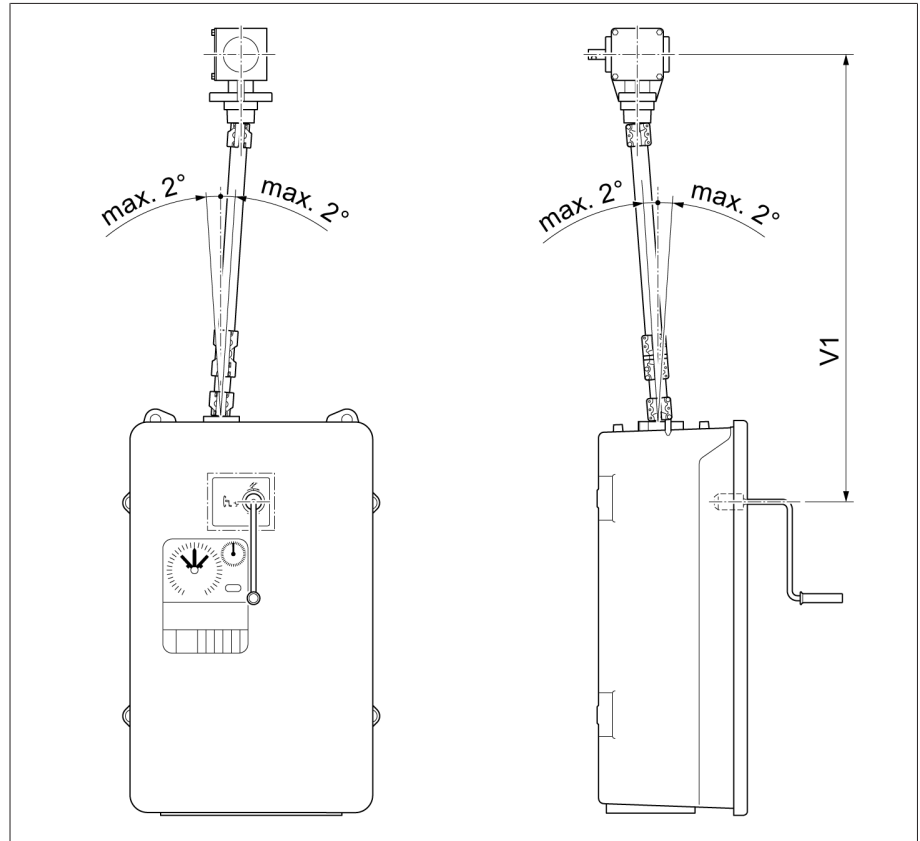

Figure 15: Drive shaft without cardan joint and with insulator (= special model)

Configuration	V 1 min	Intermediate bearing
Middle of hand crank – middle of bevel gear (maximum permissible axial offset 2°)	706 mm	When the maximum value of 2472 mm is exceeded, it is necessary to use an intermediate bearing. $V 1 \leq 2472$ mm (without intermediate bearing) $V 1 > 2472$ mm (with intermediate bearing)

3.3.2.3 Drive shaft with cardan joints, without insulator

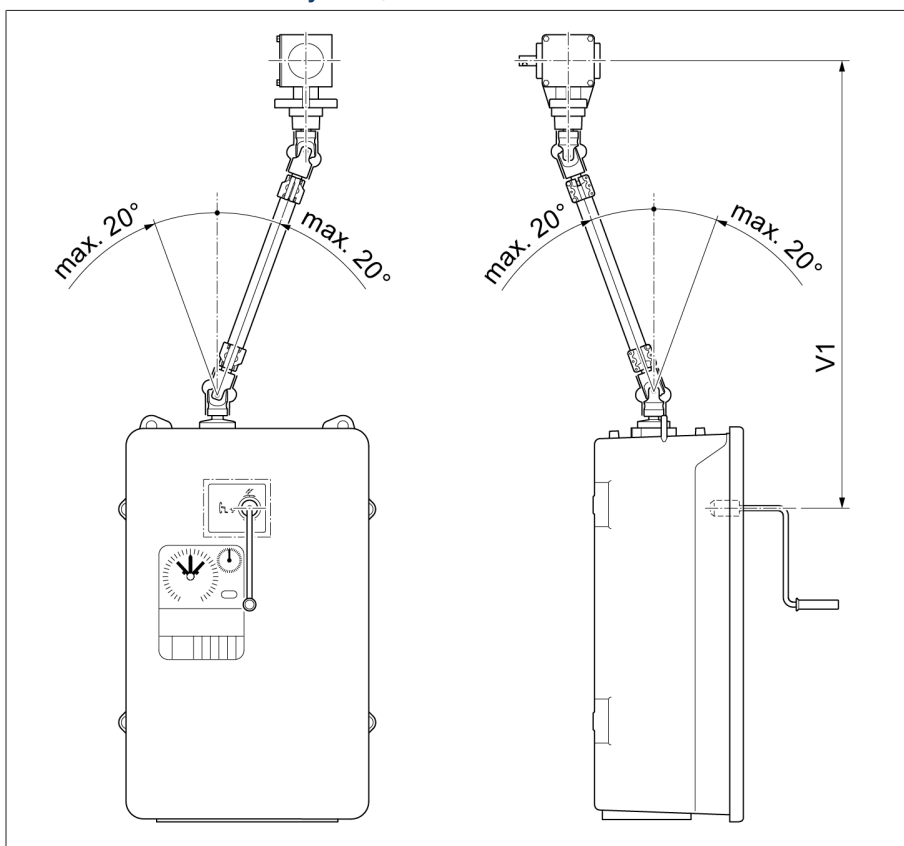

Figure 16: Drive shaft with cardan joints, without insulator (= special model)

Configuration	V 1 min [mm]	Intermediate bearing for [mm]
Middle of hand crank – middle of bevel gear (maximum permissible axial offset 20°)	798	V 1 > 2564

3.3.2.4 Drive shaft with cardan joints, with insulator

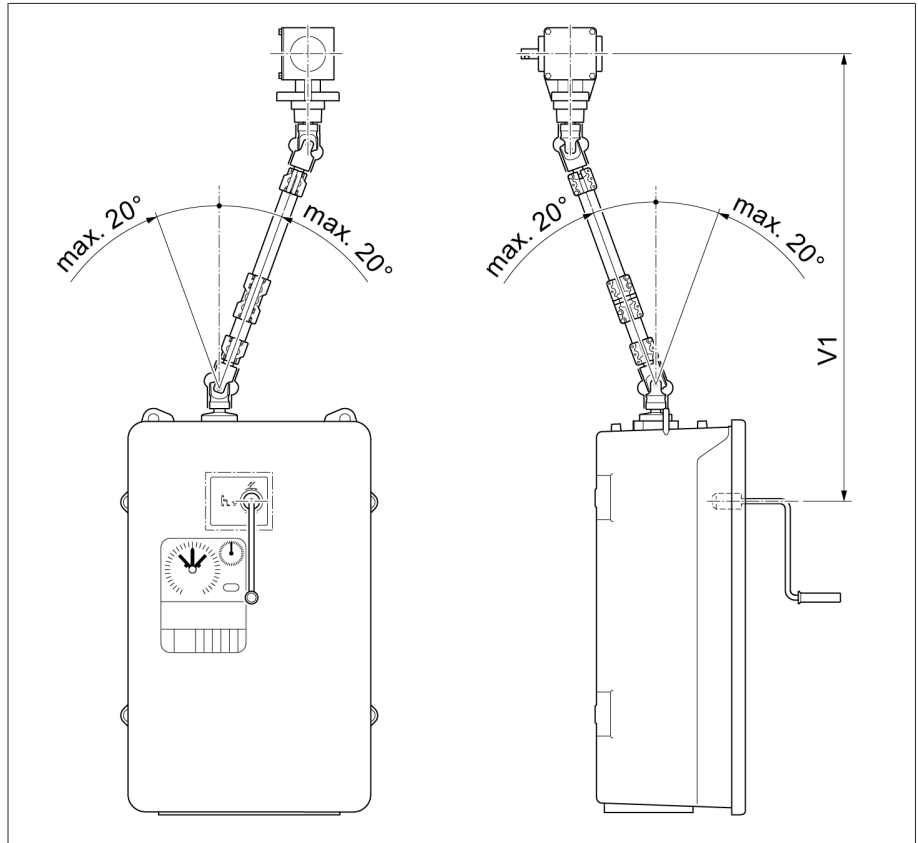

Figure 17: Drive shaft with cardan joints, with insulator (= special model)

Configuration	V 1 min [mm]	Intermediate bearing for [mm]
Middle of hand crank – middle of bevel gear (maximum permissible axial offset 20°)	978	V 1 > 2772

4 Packaging, transport and storage

4.1 Packaging

The products are sometimes supplied with sealed packaging and sometimes in a dry state, depending on requirements.

Sealed packaging surrounds the packaged goods with plastic foil on all sides.

Products that have also been dried are identified by a yellow label on the sealed packaging. In the dry state, delivery is also possible in a transport container.

The information in the following sections should be applied as appropriate.

4.1.1 Suitability

NOTICE

Property damage due to incorrectly stacked crates!

Stacking the crates incorrectly can lead to damage to the packaged goods.

- > The outer marking on the packaging states if, for example, the on-load tap-changer or selector has been packed upright. Never stack these crates.
- > General rule: Do not stack crates above a height of 1.5 m.
- > For other crates: Only stack up to 2 equally sized crates on top of one another.

The packaging is suitable to ensure undamaged and fully functional means of transportation in compliance with local transportation laws and regulations.

The packaged goods are packed in a sturdy crate. This crate ensures that, when in the intended transportation position, the packaged goods are stabilized to prevent impermissible changes in position, and that none of the parts touch the loading surface of the means of transport or touch the ground after unloading.

Sealed packaging surrounds the packaged goods with plastic foil on all sides. The packaged goods are protected from humidity using a desiccant. The plastic foil was bonded after the desiccant is added.

4.1.2 Markings

The packaging bears a signature with instructions for safe transport and correct storage. The following symbols apply to the shipment of non-hazardous goods. Adherence to these symbols is mandatory.





				
Protect against moisture	Top	Fragile	Attach lifting gear here	Center of mass

Table 3: Shipping pictograms

4.2 Transportation, receipt and handling of shipments

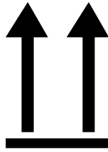
▲ WARNING



Danger of death or severe injury!

Danger of death or serious injuries due to tipping or falling load.

- > Only transport the crate when closed.
- > Do not remove the securing material used in the crate during transport.
- > If the product is delivered on a pallet, secure it sufficiently.
- > Only trained and authorized persons may select the sling gear and secure the load.
- > Do not walk under the suspended load.
- > Use means of transport and lifting gear with a sufficient carrying capacity in accordance with the weight stated on the delivery slip.

In addition to oscillation stress, jolts must also be expected during transportation. In order to prevent possible damage, avoid dropping, tipping, knocking over and colliding with the product.

If a crate tips over, falls from a certain height (e.g. when slings tear) or experiences an unbroken fall, damage must be expected regardless of the weight.

Every delivered shipment must be checked for the following by the recipient before acceptance (acknowledgment of receipt):

- Completeness based on the delivery slip
- External damage of any type

The checks must take place after unloading when the crate or transport container can be accessed from all sides.

- Visible damage** If external transport damage is found upon receipt of the shipment, proceed as follows:
- Immediately record the identified transport damage in the shipping documents and have this countersigned by the carrier.
 - In the event of severe damage, total loss or high damage costs, immediately notify the manufacturer and the relevant insurance company.
 - After identifying damage, do not modify the condition of the shipment further and retain the packaging material until an inspection decision has been made by the transport company or the insurance company.
 - Record the details of the damage immediately on site together with the carrier involved. This is essential for any claim for damages.
 - Photograph damage to packaging and packaged goods. This also applies to signs of corrosion on the packaged goods due to moisture inside the packaging (rain, snow, condensation).
 - **NOTICE!** Damage to packaged goods due to damaged sealed packaging. If the product is delivered in sealed packaging, check the sealed packaging immediately. If the sealed packaging is damaged, do not under any circumstances install or commission the packaged goods. Either re-dry the dried packaged goods as per the operating instructions, or contact the manufacturer to agree on how to proceed.
 - Identify the damaged parts.
- Hidden damage** When damages are not determined until unpacking after receipt of the shipment (hidden damage), proceed as follows:
- Make the party responsible for the damage liable as soon as possible by telephone and in writing, and prepare a damage report.
 - Observe the time periods applicable to such actions in the respective country. Inquire about these in good time.

With hidden damage, it is very hard to make the transportation company (or other responsible party) liable. Any insurance claims for such damages can only be successful if relevant provisions are expressly included in the insurance terms and conditions.

4.3 Storage of shipments

Packaged goods dried by Maschinenfabrik Reinhausen

Upon receipt of the shipment, immediately remove the packaged goods dried by Maschinenfabrik Reinhausen from the sealed packaging and store air-tight in dry insulating fluid until used if the packaged goods were not supplied in insulating fluid.

Non-dried packaged goods

Non-dried packaged goods but with a functional sealed packaging can be stored outdoors when the following conditions are complied with.

When selecting and setting up the storage location, ensure the following:

- Protect stored goods against moisture (flooding, water from melting snow and ice), dirt, pests such as rats, mice, termites and so on, and against unauthorized access.
- Store the crates on timber beams and planks as a protection against rising damp and for better ventilation.
- Ensure sufficient carrying capacity of the ground.
- Keep entrance paths free.
- Check stored goods at regular intervals. Also take appropriate action after storms, heavy rain or snow and so on.

Protect the packaging foil from direct sunlight so that it does not disintegrate under the influence of UV rays, which would cause the packaging to lose its sealing function.

If the product is installed more than 6 months after delivery, suitable measures must be taken without delay. The following measures can be used:

- Correctly regenerate the drying agent and restore the sealed packaging.
- Unpack the packed goods and store in a suitable storage space (well ventilated, as dust-free as possible, humidity < 50% where possible).

4.4 Unpacking shipments and checking for transportation damages

- **NOTICE!** Damage to packaged goods due to ineffectively sealed packaging. Transport the packaged crate to the place where the packaged goods are to be installed. Do not open the sealed packaging until just before installation.
- **⚠ WARNING!** Serious injuries and damage to the packaged goods due to the packaged goods tipping out. Place the packaged goods in an upright crate and protect it from tipping out.
- Unpack the packaged goods and check the condition.
- Check the completeness of the accessories kit using the delivery slip.

5 Mounting

⚠ WARNING



Risk of crushing!

When the on-load tap-changer undertakes a tap-change operation, components – some of which are freely accessible – move on the selector, change-over selector, and potential connection unit. Reaching into the selector, change-over selector, or potential connection unit during a tap-change operation may result in serious injuries.

- > Keep at a safe distance of at least 1 m during tap-change operations.
- > Do not reach into the selector, change-over selector, or potential connection unit during tap-change operations.
- > Do not switch the on-load tap-changer during work on the selector, change-over selector, or potential connection unit.

5.1 Preparatory work

Perform the work stated below before installing the on-load tap-changer in the transformer.

5.1.1 Fitting mounting flange on transformer cover

A mounting flange is required for fitting the on-load tap-changer head on the transformer cover. This can be supplied as an option or can be produced by the customer. Mounting flanges made by the customer must comply with the installation drawings in the appendix.

- > **NOTICE!** Fit mounting flange on transformer cover (pressure tight). Ensure that the sealing face makes complete contact and is not damaged.

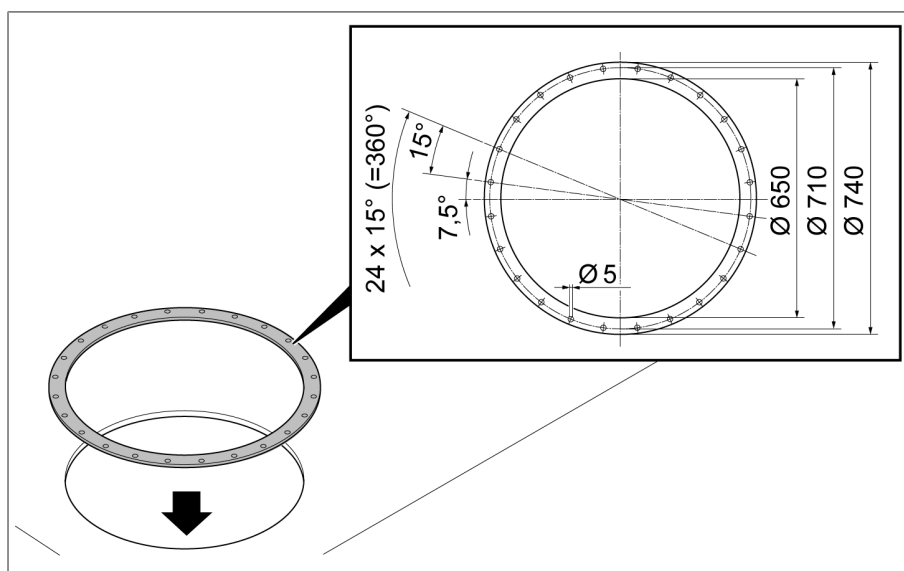

Figure 18: Mounting flange

5.1.2 Fitting stud bolts on mounting flange

To attach the stud bolts to the mounting flange, use a tracing template. This can be provided upon request free of charge for the initial installation of the on-load tap-changer.

1. Place tracing template on mounting flange and use the four markings to align.
2. Fit stud bolts on mounting flange.

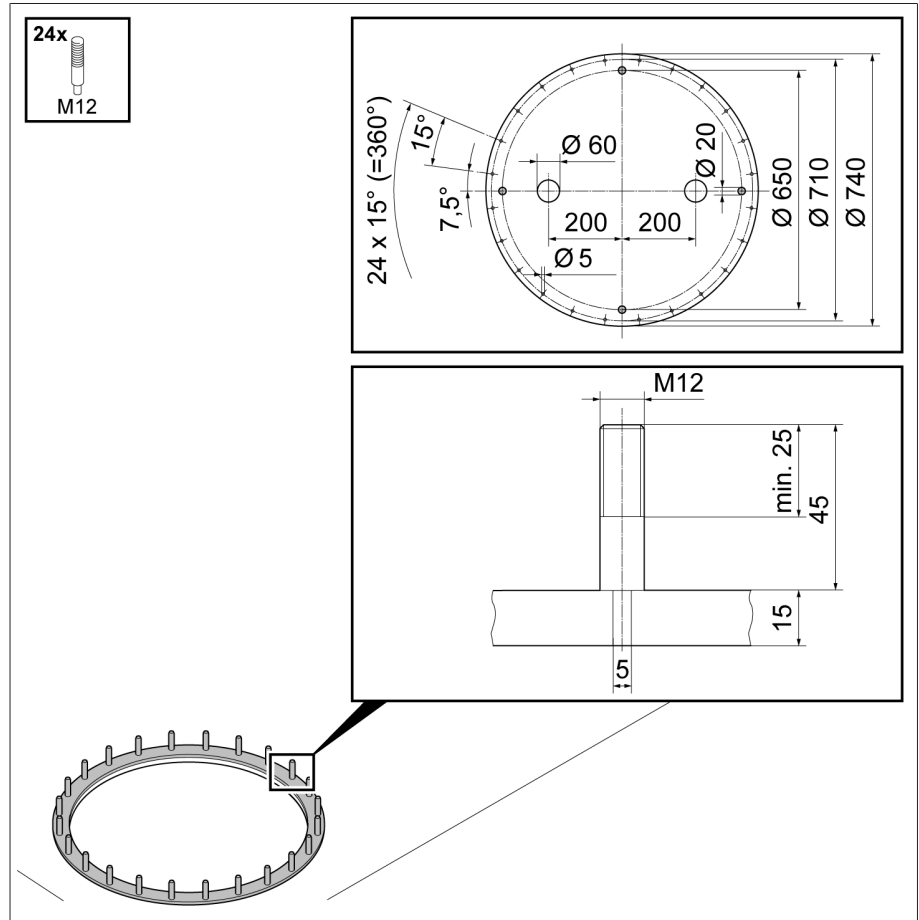

Figure 19: Tracing template, stud bolts

5.2 Installing the on-load tap-changer in the transformer (standard version)

5.2.1 Fastening on-load tap-changer to transformer cover

5.2.1.1 Fastening oil compartment on transformer cover

1. **CAUTION!** An unstably positioned oil compartment may tip over, resulting in injuries or property damage. Place the oil compartment on a level surface and secure it against tipping.
2. Remove red-colored packaging material and transport material from the oil compartment.
3. **NOTICE!** Unsuitable gaskets may lead to oil escaping and therefore to damage to the on-load tap-changer. Place a gasket **1** suitable for the insulating medium in use on the mounting flange **2**. Clean the sealing surfaces on the mounting flange and on-load tap-changer head.

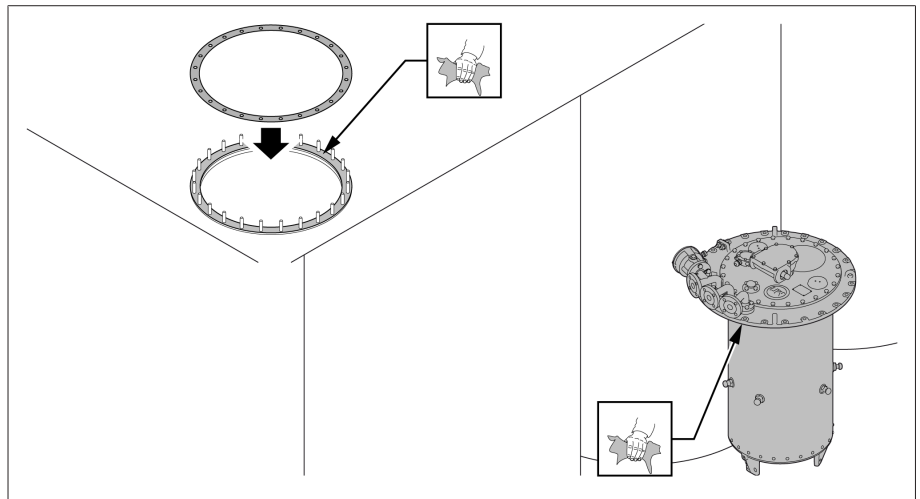

Figure 20: Sealing surfaces, gasket

4. **NOTICE!** Lowering the oil compartment without due care can result in the oil compartment colliding with the transformer cover and becoming damaged. Lift the oil compartment by hooking up the on-load tap-changer head and carefully lower it vertically into the opening of the transformer cover.

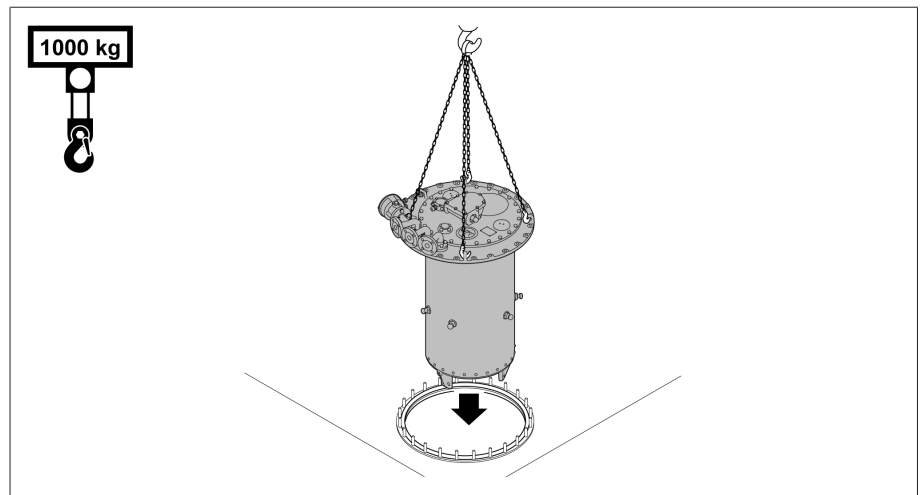

Figure 21: Lowering oil compartment

5. Check that the on-load tap-changer head is mounted in the position specified by the design.

6. Screw the on-load tap-changer head to the mounting flange.

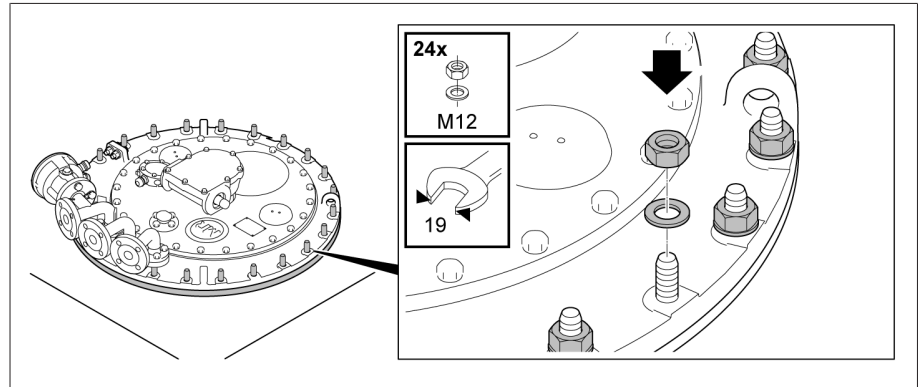

Figure 22: On-load tap-changer head with mounting flange

7. Remove the blocking strip from the coupling of the oil compartment base.

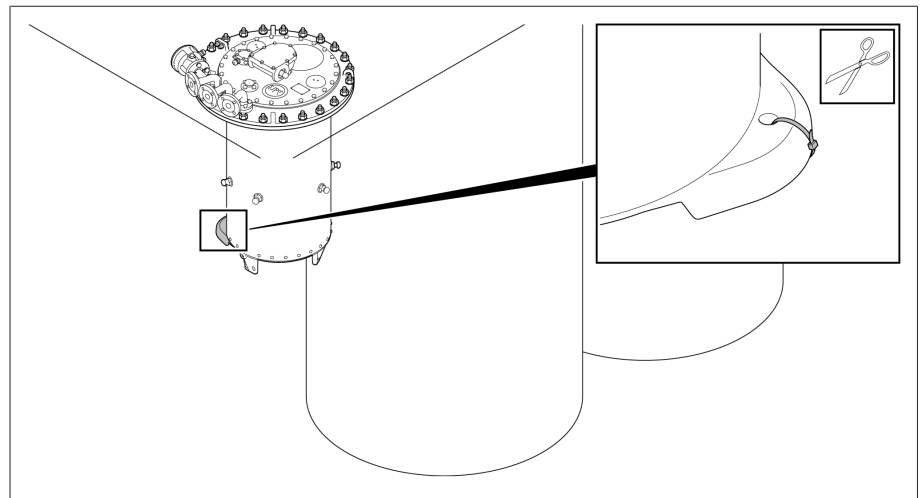

Figure 23: Blocking strip

5.2.1.2 Securing selector on oil compartment

1. **CAUTION!** An unstably positioned selector may tip, resulting in injuries or property damage. Place the selector on a level surface and secure it against tipping.
2. Remove red-colored packaging material and transport material from the selector. Only remove the red protective cap on the 0-bar of the change-over selector after fixing the selector to the oil compartment.

3. Remove plastic bag with fastening materials from the selector and keep it ready.

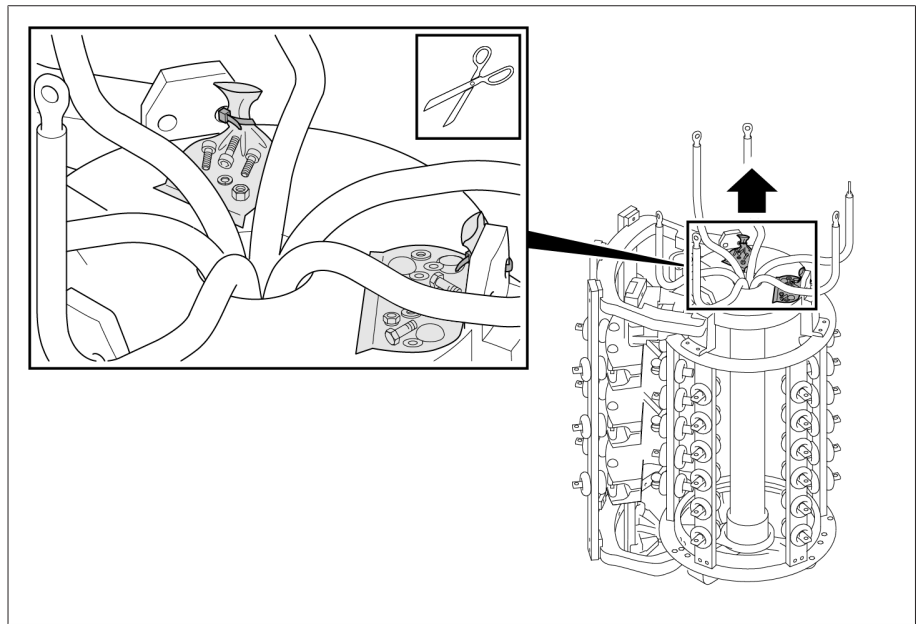

Figure 24: Plastic bag with fastening materials

4. Remove the blocking strip from the selector coupling. Once the blocking strip is removed, the selector coupling may no longer be turned.

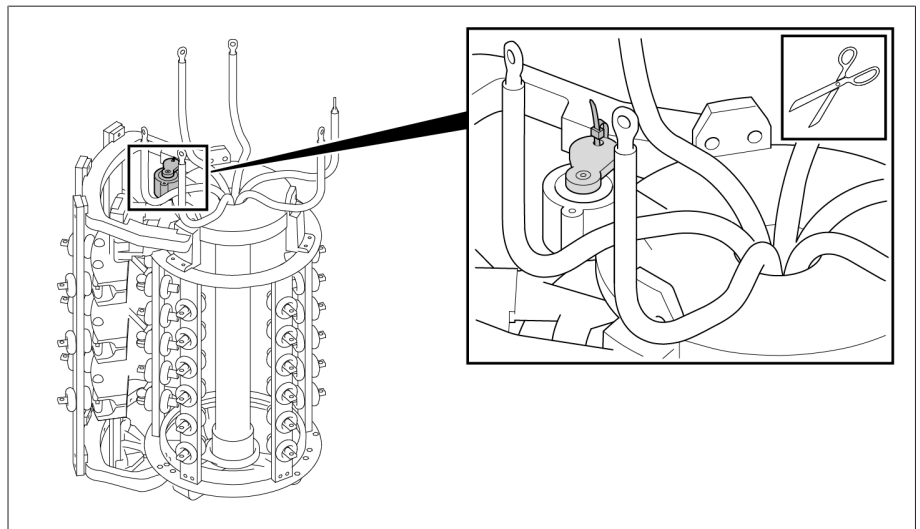

Figure 25: Selector coupling with blocking strip

5. Place the selector on the lifting device. The weight of the selector is a maximum of 165 kg.
6. **NOTICE!** Lifting the selector without due care can result in the selector and oil compartment colliding and becoming damaged. Carefully lift the selector below the oil compartment, ensuring that the tap-selector connecting leads and potential connection unit (if installed) are free when lifting the selector onto the oil compartment, and that they do not touch the compartment.
7. Align the position of both coupling parts and attachment points on the oil compartment and the selector with one another. The correct position of the two coupling parts is shown in the adjustment plans supplied.

8. Screw selector onto oil compartment.

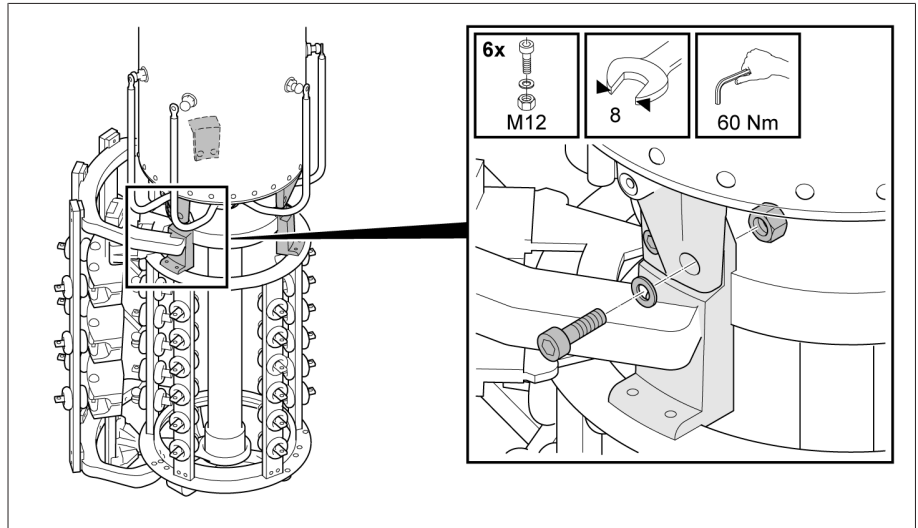

Figure 26: Selector with oil compartment

9. **NOTICE!** Incorrect tightening torques and unsecured screw connections can lead to damage to the on-load tap-changer. Screw the tap-selector connecting leads to connecting piece with care. Comply with the specified tightening torque, secure screw connections and snap the screening caps in place over the screw heads.

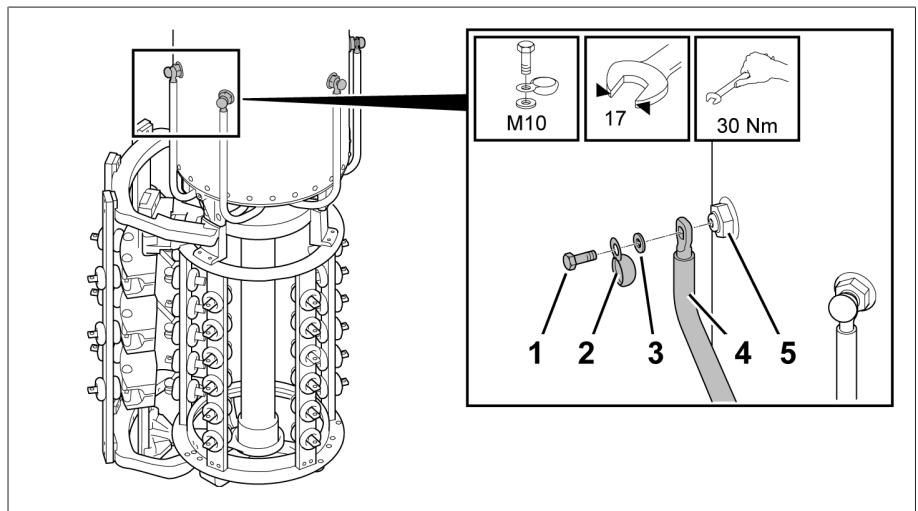

Figure 27: Tap-selector connecting leads

10. Remove the red protective cap on the 0-bar of the change-over selector.

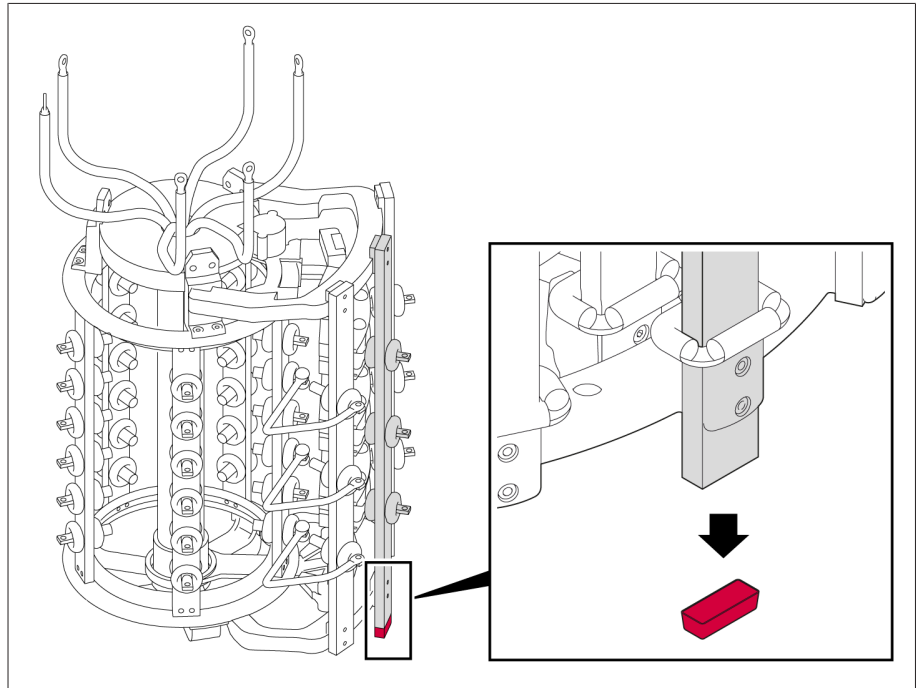

Figure 28: Protective cap

11. Secure selector with pitch of tap selector contact circle 36 to prevent it twisting as a result of being turned and slid. There are 3 holes, 20 mm in diameter, in the selector base for this purpose. Ensure that it can still be slid in an axial direction.



The selector's pitch of tap selector contact circle is stated in the on-load tap-changer's type designation after the selector size.
Example: M I 501-123/B-36340 (B = selector size, 36 = pitch of tap selector contact circle)

5.2.2 Connecting the tap winding and on-load tap-changer take-off lead

NOTICE

Damage to the on-load tap-changer!

Connecting leads that place mechanical strain on the on-load tap-changer will damage the on-load tap-changer.

- > Establish connections carefully.
- > Do not twist connection contacts.
- > Connect connecting leads without warping or deforming.
- > If necessary, use an expansion loop for connecting leads.
- > Fit screening caps provided to screw connections.

The tap winding and on-load tap-changer take-off lead must be connected in accordance with the connection diagram included with the delivery.

5.2.2.1 Tap selector connection contacts

The tap selector connection contacts are provided with a through-hole for M10 screws. The through-holes are either horizontal or vertical, depending on the on-load tap-changer model.

1. Fasten the tap-winding connecting leads to the tap selector in accordance with the connection diagram provided. The cable shoes and fastening materials are not included in the scope of delivery.
2. Take suitable measures to ensure that each screw connection cannot come loose or settle (e.g. by using clamping washers). Be sure to attach the screening caps as shown in the illustration if these are included in the delivery scope.
3. Close the screening caps and make sure they are seated correctly. The screw head and nut must be fully covered.

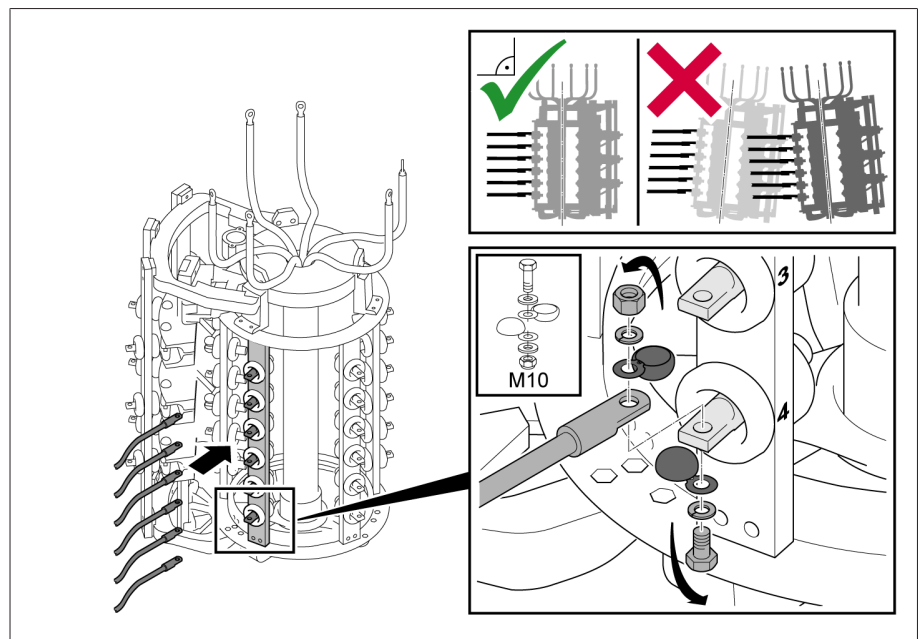

Figure 29: Tap selector connection contacts

5.2.2.2 Tap selector connection contacts for multiple coarse tapping arrangement

NOTICE

Damage to the on-load tap-changer!

Tap-winding connecting leads situated too closely to the change-over selector's moving parts block the change-over selector and therefore result in damage to the on-load tap-changer.

- > Tap-winding connecting leads in the area of the change-over selector have to be routed such that they are at a sufficient distance from the change-over selector's moving parts.

In the case of multiple coarse change-over selectors, take care when routing the cables for connecting to the tap selector connection contacts and the multiple coarse change-over selector connection contacts. These cables should be as far away as possible from neighboring connection contacts.

1. The tap selector connection contacts that face both multiple coarse change-over selector columns must have at least 3 mm of paper insulation to ensure dielectric strength.
2. Please pay attention to the dimensional drawing on which the order is based.

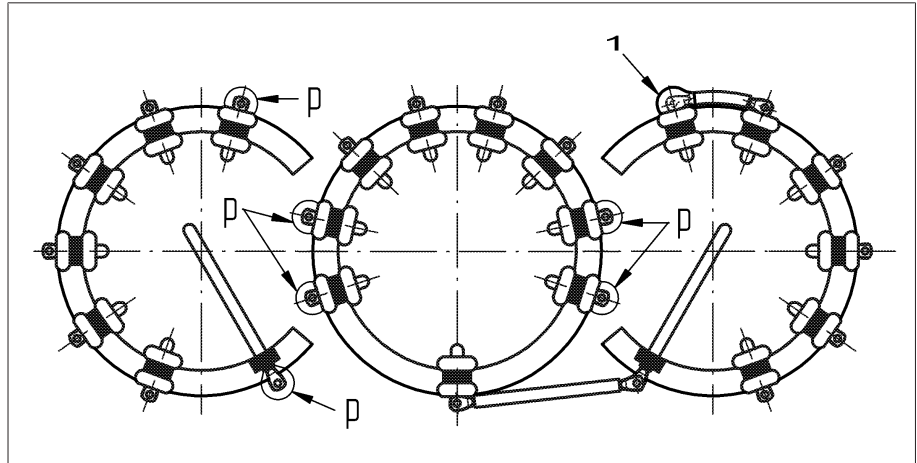

Figure 30: Paper insulation

1	Connection from MR already has 3 mm of paper insulation	p	Connections to be insulated
---	---	---	-----------------------------

5.2.2.3 Change-over selector connection contacts for reversing change-over selector connection

NOTICE

Damage to the on-load tap-changer!

Tap-winding connecting leads situated too closely to the change-over selector's moving parts block the change-over selector and therefore result in damage to the on-load tap-changer.

- > Tap-winding connecting leads in the area of the change-over selector have to be routed such that they are at a sufficient distance from the change-over selector's moving parts.

The (+) and (-) change-over selector connection contacts are designed as connecting lugs with through-holes for M10 screws for reversing change-over selector connection.

The connection contact K is designed as an extended tap selector connection contact with through-hole for M10 screws.

1. Fasten the tap-winding connecting leads to the change-over selector in accordance with the connection diagram provided. The cable shoes and fastening materials are not included in the scope of delivery.
2. Take suitable measures to ensure that each fitting cannot come loose or settle (e.g. by using clamping washers). Be sure to attach the screening caps if these are included in the delivery scope.

3. Close the screening caps and make sure they are seated correctly. The screw head and nut must be fully covered.

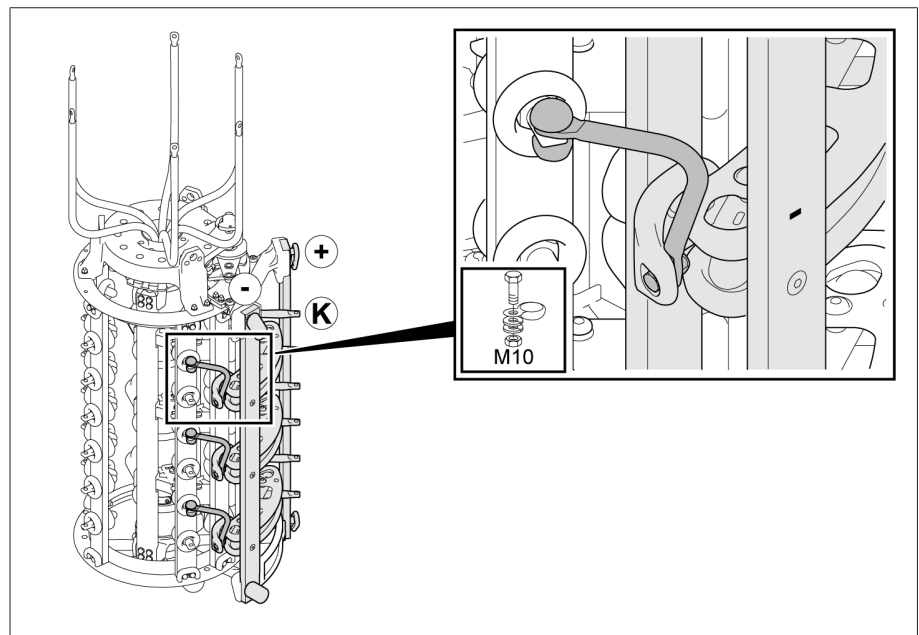

Figure 31: Change-over selector connection contacts for reversing change-over selector connection

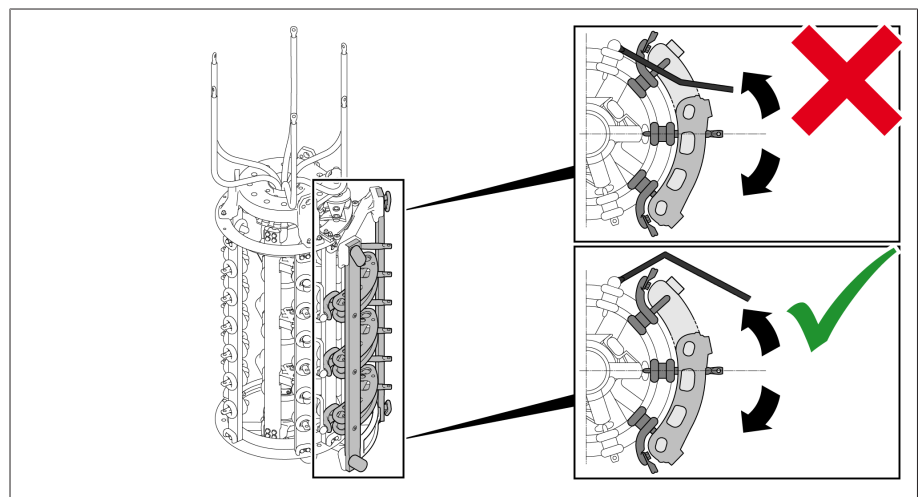

Figure 32: Change-over selector connection contacts for reversing change-over selector connection (top view)

5.2.2.4 Change-over selector connection contacts for coarse tap selector connection

NOTICE

Damage to the on-load tap-changer!

Tap-winding connecting leads situated too closely to the change-over selector's moving parts block the change-over selector and therefore result in damage to the on-load tap-changer.

- > Tap-winding connecting leads in the area of the change-over selector have to be routed such that they are at a sufficient distance from the change-over selector's moving parts.

With coarse tap selector connection, the external appearance of the (+) and (-) change-over selector connection contacts is identical to the tap selector contacts (through-hole for M10 screws, always in vertical position).

1. Fasten the tap-winding connecting leads to the change-over selector in accordance with the connection diagram provided. The cable shoes and fastening materials are not included in the scope of delivery.
2. Take suitable measures to ensure that each fitting cannot come loose or settle (e.g. by using clamping washers). Be sure to attach the screening caps if these are included in the delivery scope.
3. Close the screening caps and make sure they are seated correctly. The screw head and nut must be fully covered.

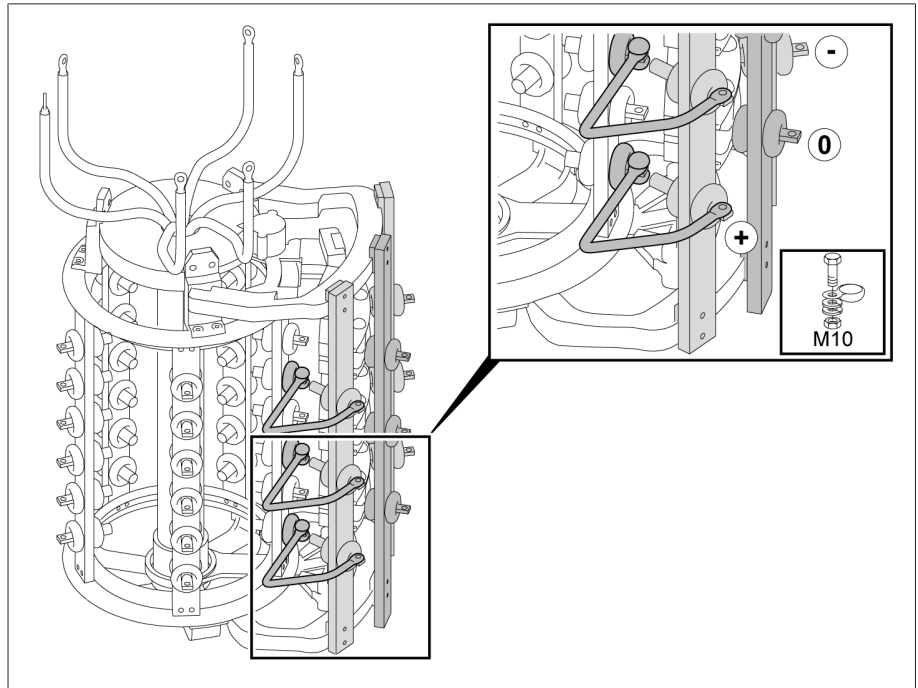

Figure 33: Change-over selector connection contacts for coarse tap selector connection

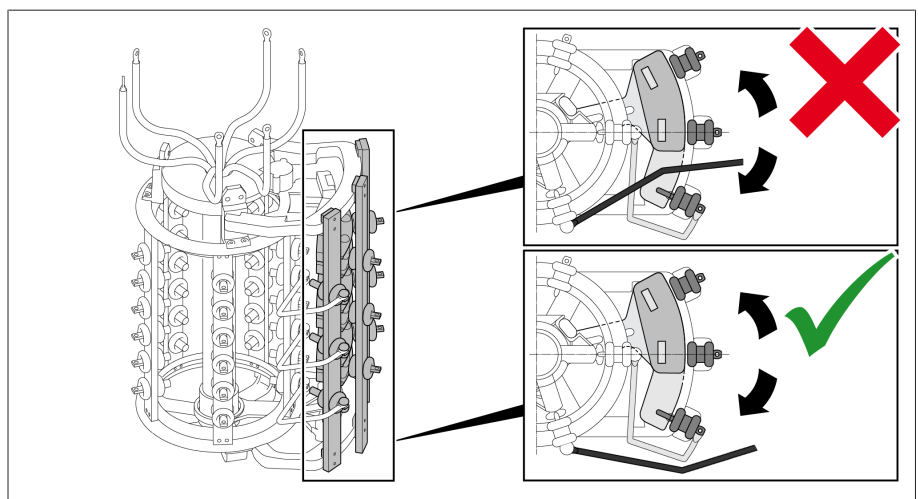

Figure 34: Change-over selector connection contacts for coarse tap selector connection (top view)

5.2.2.5 Change-over selector connection contacts for multiple coarse tapping arrangement

NOTICE

Damage to the on-load tap-changer!

Tap-winding connecting leads situated too closely to the change-over selector's moving parts block the change-over selector and therefore result in damage to the on-load tap-changer.

- > Tap-winding connecting leads in the area of the change-over selector have to be routed such that they are at a sufficient distance from the change-over selector's moving parts.

With a multiple coarse tapping arrangement, the external appearance of the change-over selector connection contacts is identical to the tap selector contacts (through-hole for M10 screws, always in vertical position).

1. Fasten the tap-winding connecting leads to the change-over selector in accordance with the connection diagram provided. The cable shoes and fastening materials are not included in the scope of delivery.
2. Take suitable measures to ensure that each fitting cannot come loose or settle (e.g. by using clamping washers). Be sure to attach the screening caps if these are included in the delivery scope.
3. Close the screening caps and make sure they are seated correctly. The screw head and nut must be fully covered.

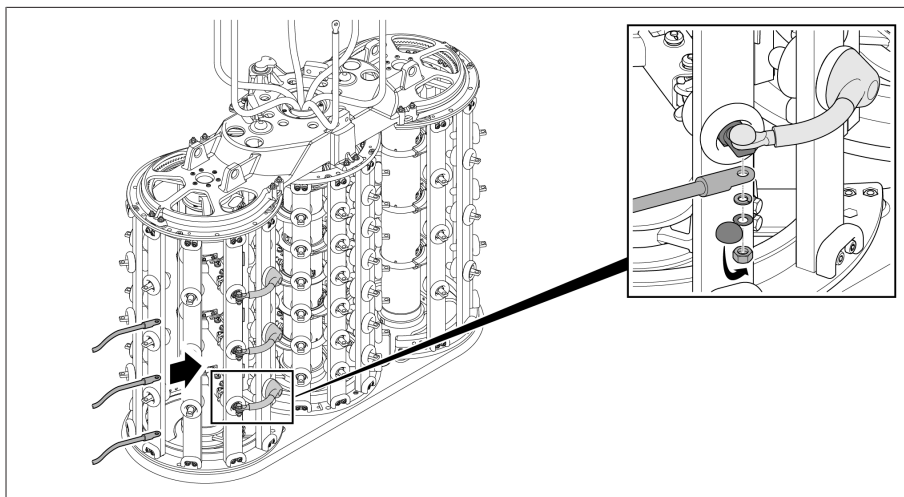

Figure 35: Change-over selector connection contacts for multiple coarse tapping arrangement

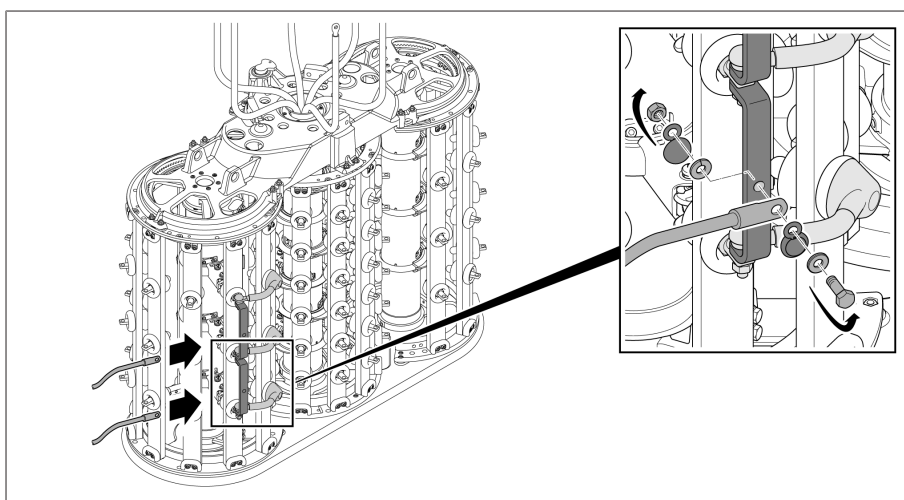

Figure 36: Change-over selector connection contacts for multiple coarse tapping arrangement with bridges on the connection contacts

5.2.2.6 Connecting on-load tap-changer take-off lead

5.2.2.6.1 Take-off lead connection directly on oil compartment

1. Connect the on-load tap-changer take-off lead to the take-off lead connection using the cable shoe and screw. The cable shoe and fastening materials are not included in the scope of delivery.
2. Take suitable measures to ensure the screw connection cannot come loose or settle (e.g. by using clamping washers).

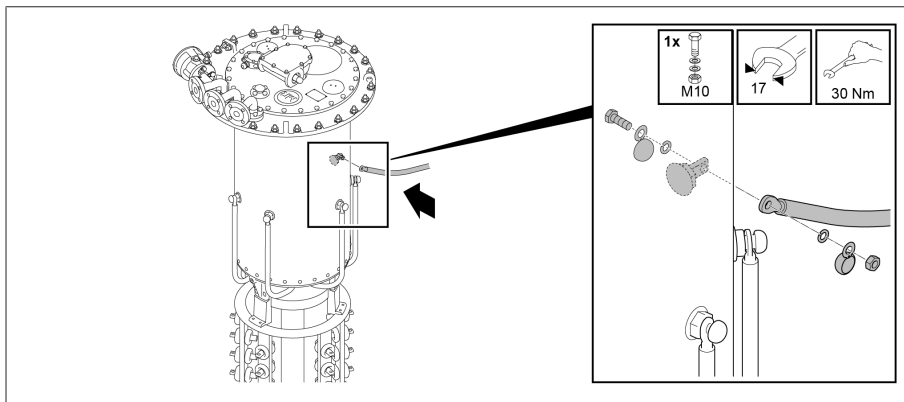

Figure 37: Take-off lead connection on oil compartment

5.2.2.6.2 Take-off lead connection on take-off ring

1. Connect the on-load tap-changer take-off lead to 1 of the 3 through-holes on the take-off ring using a cable shoe and screw. The cable shoe and fastening materials are not included in the scope of delivery.
2. Pay attention to the screw length. A minimum distance of 2 mm must be maintained between screw and oil compartment.

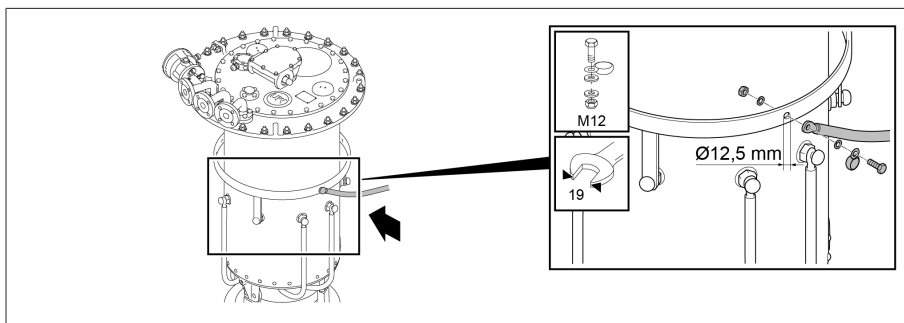

Figure 38: Connecting ring of oil compartment

3. Take suitable measures to ensure the screw connection cannot come loose or settle (e.g. by using clamping washers).

NOTICE

5.2.3 Performing transformer ratio test before drying Damage to the on-load tap-changer!

Damage to the on-load tap-changer due to transformer ratio test being incorrectly performed.

- › Do not perform more than 250 tap-change operations on the on-load tap-changer. If more than 250 tap-change operations are to be performed, completely fill the oil compartment with insulating fluid and lubricate sliding surfaces of contacts on the selector and selector gear with insulating fluid.
- › Only switch the on-load tap-changer from one operating position to the next via the upper gear unit. You can use a short tube (diameter 25 mm) with screwed-in coupling bolt (diameter 12 mm) with a hand wheel or crank for this, for example. When using a drill, do not exceed a maximum speed of 250 rpm.
- › Always check the operating position reached through the inspection window in the on-load tap-changer head cover. Never overshoot the end positions, which are indicated in the connection diagram supplied with the delivery.
- › For multiple-column applications with a shared drive, link all on-load tap-changer heads to one another using the horizontal drive shaft parts.



When actuating the change-over selector, a higher torque is required.

1. Switch the on-load tap-changer into the desired operating position. The diverter switch operation can be heard distinctly.
2. **NOTICE!** An incomplete tap-change operation may damage the on-load tap-changer. After operating the diverter switch, continue to crank the drive shaft of the upper gear unit for 2.5 revolutions in the same direction in order to correctly complete the tap-change operation.
3. Perform the transformer ratio test.
4. Repeat the transformer ratio test in all operating positions.
5. Switch the on-load tap-changer into adjustment position (see the accompanying connection diagram for the on-load tap-changer).



After the transformer ratio test, open the kerosene drain plug in the oil compartment if the on-load tap-changer is to be dried with kerosene in the transformer tank. After drying, the diverter switch insert must be removed, the kerosene drain plug in the oil compartment closed and the diverter switch insert refitted.

NOTICE

5.2.4 Performing DC resistance measurement on transformer Damage to the on-load tap-changer.

Excessive measurement currents overload the contacts of the on-load tap-changer and thus cause damage to the on-load tap-changer.

- › Ensure that the maximum permissible measurement currents specified in the following table are not exceeded.

- › Perform the DC resistance measurement in various on-load tap-changer operating positions in accordance with the following table.

Status of oil compartment	Without interruption of the measured current	With interruption (measured current = 0 A before change of operating position)
Oil compartment empty	Maximum 10 A DC	Maximum 50 A DC
Oil compartment filled with insulating fluid	Maximum 50 A DC	Maximum 50 A DC

Table 4: Maximum permitted measured currents when performing DC resistance measurement on transformer

NOTICE

5.2.5 Drying on-load tap-changer in autoclave Damage to the on-load tap-changer!

Moisture in the oil compartment reduces the dielectric strength of the insulating fluid and thus leads to damage to the on-load tap-changer.

- > Within 10 hours of drying, seal off oil compartment with on-load tap-changer head cover.

Dry on-load tap-changer in accordance with the following instructions to ensure the dielectric values assured by MR for the on-load tap-changer.

If drying in an autoclave, the following methods are possible:

- Vacuum drying
- Vapor-phase drying

As an alternative to drying the on-load tap-changer in an autoclave, it can also be dried in the transformer tank.

5.2.5.1 Vacuum-drying in the autoclave



If you wish to perform another transformer ratio test after drying, proceed as described in the section "Performing transformer ratio test following drying" [▶ Section 5.2.8, Page 65].

5.2.5.1.1 Moving on-load tap-changer to adjustment position

- > Move the on-load tap-changer to the adjustment position. The adjustment position is indicated in the on-load tap-changer connection diagram included in delivery.

5.2.5.1.2 Removing on-load tap-changer head cover

WARNING



Danger of explosion!

Explosive gases under the on-load tap-changer head cover can deflagrate or explode and result in severe injury or death.

- > Ensure that there are no ignition sources such as open flames, hot surfaces or sparks (e.g. caused by the build-up of static charge) in the immediate surroundings and that none occur.
- > De-energize all auxiliary circuits (for example tap-change supervisory device, pressure relief device, pressure monitoring device) before removing the on-load tap-changer head cover.
- > Do not operate any electrical devices during the work (e.g. risk of sparks from impact wrench).

NOTICE

Damage to the on-load tap-changer!

Small parts in the oil compartment may block the diverter switch insert, thereby damaging the on-load tap-changer.

- > Ensure that parts do not fall into the oil compartment.
- > Check that all small parts are accounted for.

1. Ensure that the inspection window is sealed off with the cover.
2. Remove the screws and washers from the on-load tap-changer head cover.

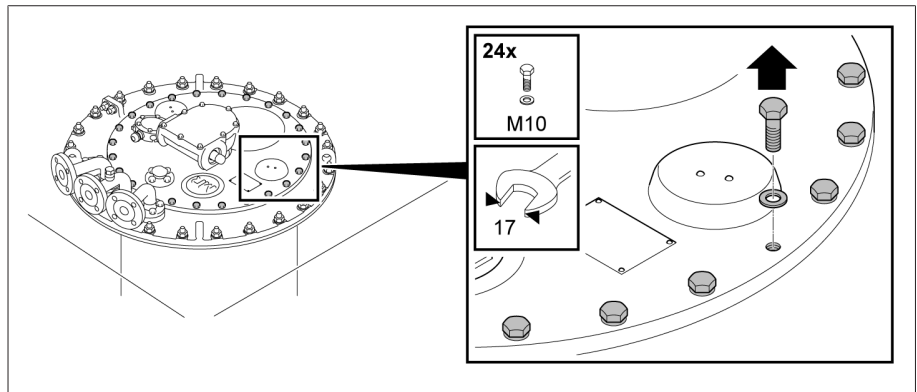

Figure 39: On-load tap-changer head cover

3. Remove on-load tap-changer head cover.

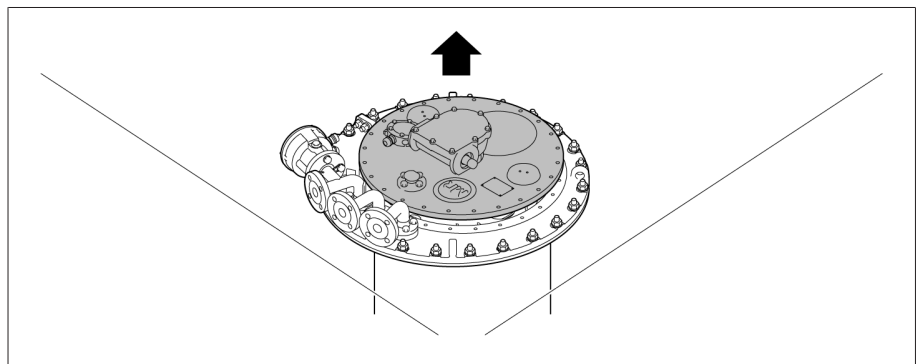

Figure 40: On-load tap-changer head cover

5.2.5.1.3 Drying the on-load tap-changer

NOTICE

Damage to the on-load tap-changer head cover and on-load tap-changer accessories.

Both the on-load tap-changer head cover and the on-load tap-changer accessories will become damaged if they are dried.

› Never dry the on-load tap-changer head cover or the following accessories: motor-drive unit, drive shaft, protective relay, pressure monitoring device, pressure relief device, bevel gear, sensors such as temperature and humidity sensors or pressure sensors, oil filter unit.

1. Heat up the on-load tap-changer in air at atmospheric pressure with a temperature increase of approximately 10 °C/h to a final temperature of maximum 110 °C.
2. Pre-dry the on-load tap-changer in circulating air at a maximum temperature of 110 °C for a period of at least 20 hours.
3. Vacuum-dry on-load tap-changer at between 105 °C and maximum 125 °C for at least 50 hours.
4. Residual pressure of no more than 10⁻³ bar.

5.2.5.1.4 Securing on-load tap-changer head cover

NOTICE

Damage to the on-load tap-changer!

A missing or damaged o-ring as well as unclean sealing surfaces lead to insulating fluid escaping and therefore to damage to the on-load tap-changer.

- > Ensure that the o-ring is positioned untwisted in the on-load tap-changer head cover.
- > Ensure that the o-ring does not become damaged when mounting the cover.
- > Ensure that the sealing surfaces on the on-load tap-changer head cover and on-load tap-changer head are clean.

1. Check that the feather key is securely positioned in the adapter shaft. Where necessary, use Vaseline to secure the feather key against falling out.

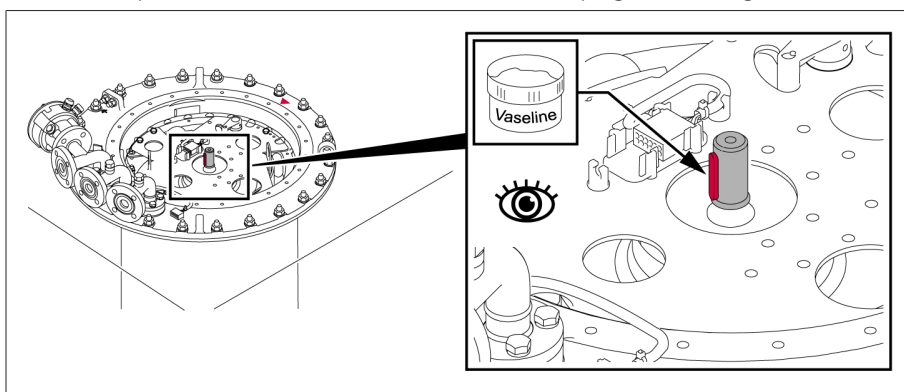

Figure 41: Feather key

2. Position the on-load tap-changer head cover on the on-load tap-changer head in such a way that the red triangular markings on the on-load tap-changer head and the on-load tap-changer head cover are aligned.

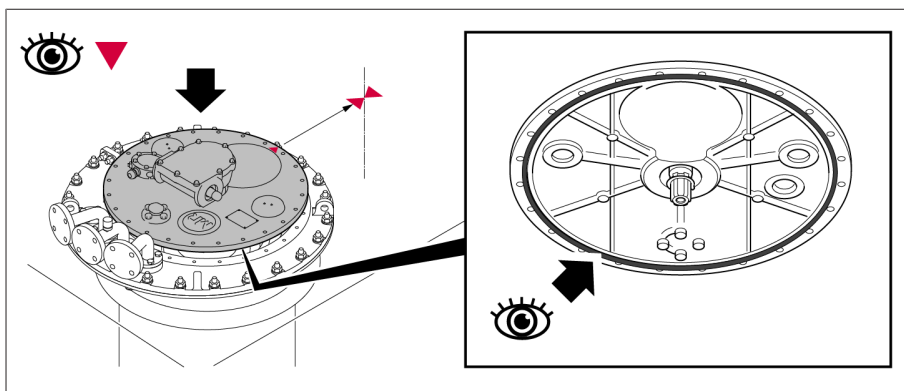

Figure 42: Triangular markings and o-ring

3. Screw the on-load tap-changer head cover onto the on-load tap-changer head.

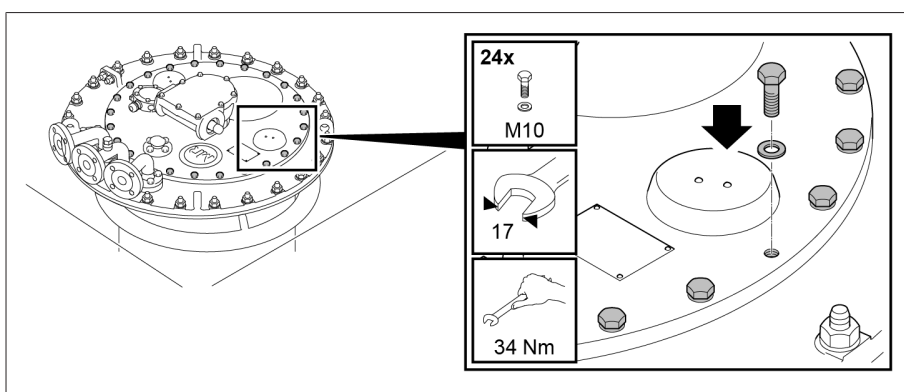

Figure 43: On-load tap-changer head cover

5.2.5.2 Vapor-phase drying in the autoclave



If you wish to perform another transformer ratio test after drying, proceed as described in the section "Performing transformer ratio test following drying" [► Section 5.2.8, Page 65].

5.2.5.2.1 Moving on-load tap-changer to adjustment position

- Move the on-load tap-changer to the adjustment position. The adjustment position is indicated in the on-load tap-changer connection diagram included in delivery.

5.2.5.2.2 Removing on-load tap-changer head cover

⚠ WARNING



Danger of explosion!

Explosive gases under the on-load tap-changer head cover can deflagrate or explode and result in severe injury or death.

- Ensure that there are no ignition sources such as open flames, hot surfaces or sparks (e.g. caused by the build-up of static charge) in the immediate surroundings and that none occur.
- De-energize all auxiliary circuits (for example tap-change supervisory device, pressure relief device, pressure monitoring device) before removing the on-load tap-changer head cover.
- Do not operate any electrical devices during the work (e.g. risk of sparks from impact wrench).

NOTICE

Damage to the on-load tap-changer!

Small parts in the oil compartment may block the diverter switch insert, thereby damaging the on-load tap-changer.

- Ensure that parts do not fall into the oil compartment.
- Check that all small parts are accounted for.

1. Ensure that the inspection window is sealed off with the cover.
2. Remove the screws and washers from the on-load tap-changer head cover.

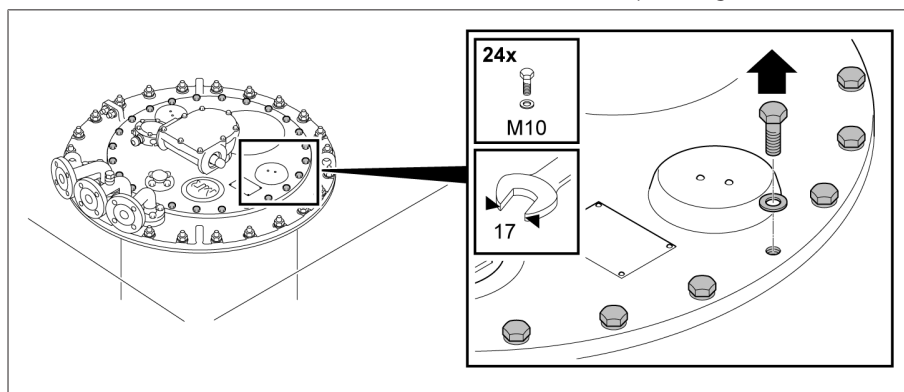

Figure 44: On-load tap-changer head cover

3. Remove on-load tap-changer head cover.

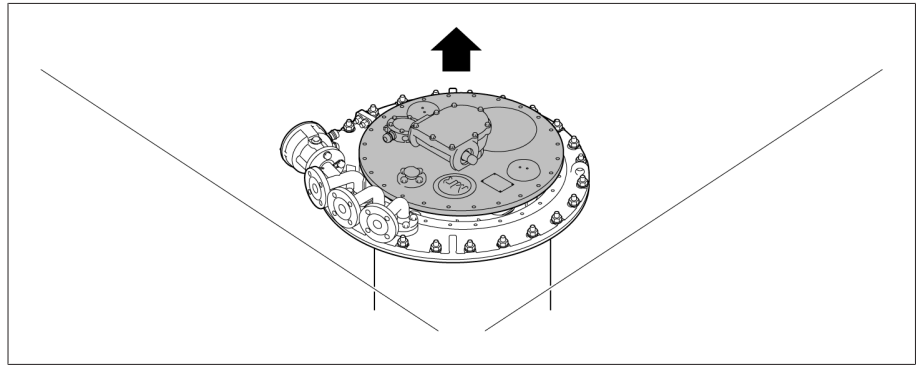

Figure 45: On-load tap-changer head cover

5.2.5.2.3 Opening kerosene drain plug

- > **NOTICE!** Never remove the kerosene drain plug completely. Only unscrew the kerosene drain plug between the oil compartment base and selector gear clockwise until it starts to become hard to open.

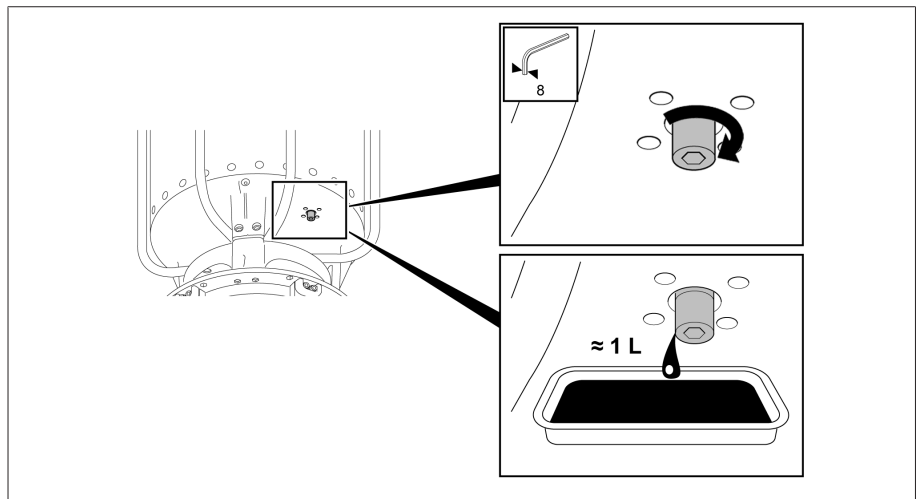

Figure 46: Kerosene drain plug

5.2.5.2.4 Drying the on-load tap-changer

NOTICE

Damage to the on-load tap-changer head cover and on-load tap-changer accessories.

Both the on-load tap-changer head cover and the on-load tap-changer accessories will become damaged if they are dried.

- > Never dry the on-load tap-changer head cover or the following accessories: motor-drive unit, drive shaft, protective relay, pressure monitoring device, pressure relief device, bevel gear, sensors such as temperature and humidity sensors or pressure sensors, oil filter unit.

1. Supply kerosene vapor at a temperature of around 90°C. Keep this temperature constant for 3 to 4 hours.
2. Increase the kerosene vapor temperature by approx. 10°C/hour to the desired final temperature of max. 125°C at the on-load tap-changer.
3. Vacuum-dry on-load tap-changer at between 105°C and maximum 125°C for at least 50 hours.
4. Residual pressure of no more than 10⁻³ bar.

5.2.5.2.5 Closing kerosene drain plug

- > **NOTICE!** An open kerosene drain plug leads to insulating fluid escaping from the oil compartment and therefore to damage to the on-load tap-changer. Close kerosene drain plug (tightening torque 20 Nm).

5.2.5.2.6 Securing on-load tap-changer head cover

NOTICE

Damage to the on-load tap-changer!

A missing or damaged o-ring as well as unclean sealing surfaces lead to insulating fluid escaping and therefore to damage to the on-load tap-changer.

- > Ensure that the o-ring is positioned untwisted in the on-load tap-changer head cover.
- > Ensure that the o-ring does not become damaged when mounting the cover.
- > Ensure that the sealing surfaces on the on-load tap-changer head cover and on-load tap-changer head are clean.

1. Check that the feather key is securely positioned in the adapter shaft. Where necessary, use Vaseline to secure the feather key against falling out.

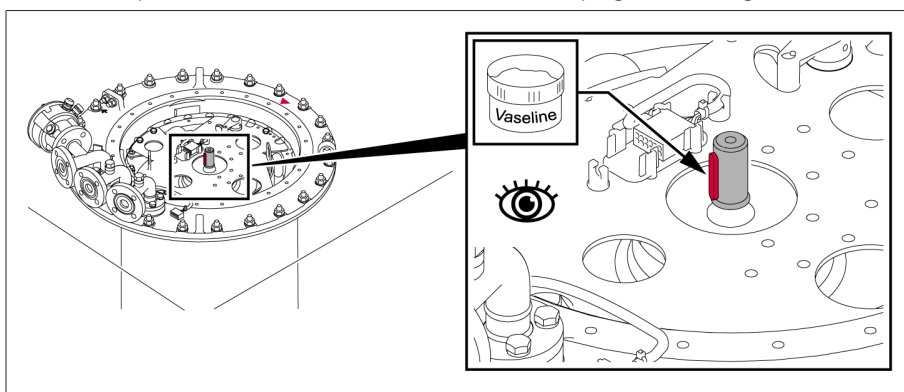

Figure 47: Feather key

2. Position the on-load tap-changer head cover on the on-load tap-changer head in such a way that the red triangular markings on the on-load tap-changer head and the on-load tap-changer head cover are aligned.

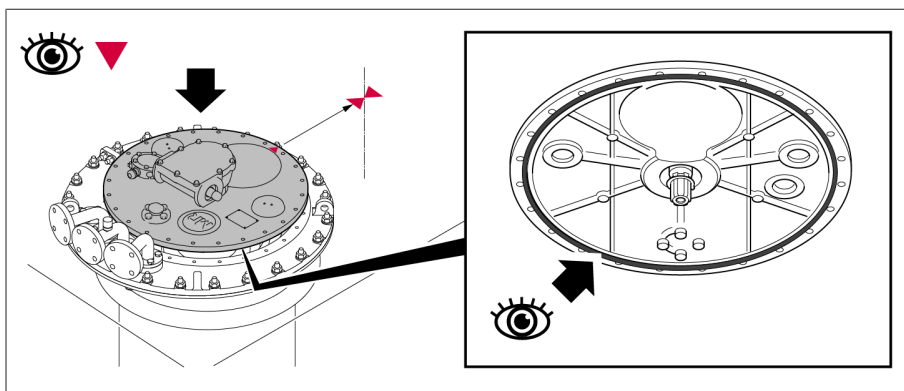

Figure 48: Triangular markings and o-ring

3. Screw the on-load tap-changer head cover onto the on-load tap-changer head.

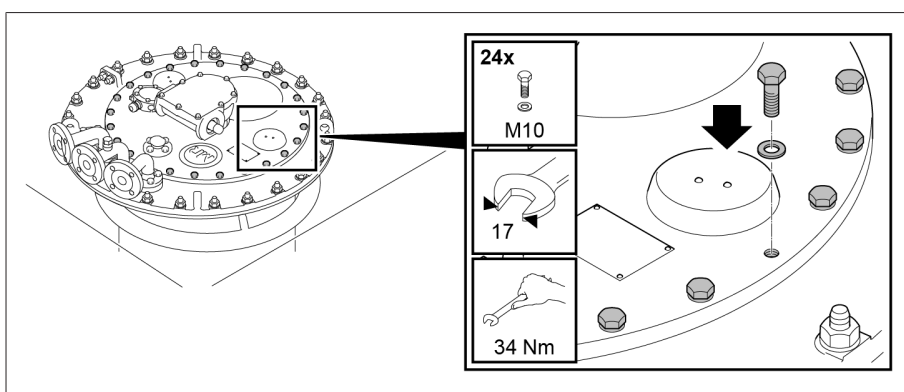

Figure 49: On-load tap-changer head cover

5.2.6 Drying on-load tap-changer in transformer tank

Dry on-load tap-changer in accordance with the following instructions to ensure the dielectric values assured by MR on the on-load tap-changer.

If you want to dry the on-load tap-changer in the transformer tank, fully assemble the transformer first and then undertake drying.

If drying in the transformer tank, the following methods are possible:

- Vacuum-drying
- Vapor-phase drying

As an alternative to drying the on-load tap-changer in the transformer tank, it can also be dried in an autoclave.

5.2.6.1 Vacuum-drying in the transformer tank



The on-load tap-changer head cover remains closed during the entire drying process.

1. Establish a connecting lead between either connections E2 and Q or connections E2 and R on the on-load tap-changer head.
2. Seal off unused pipe connections with a suitable blank cover.

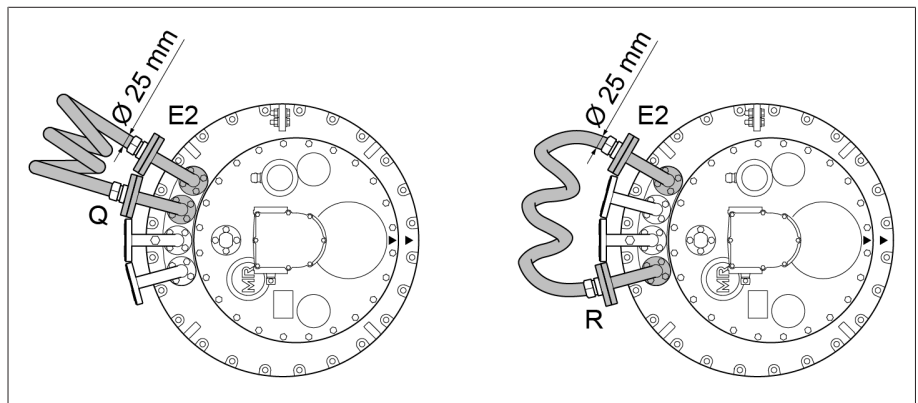

Figure 50: Connecting lead

Vacuum-drying in the transformer tank

1. Heat up the on-load tap-changer in air at atmospheric pressure with a temperature increase of approximately 10 °C/h to a final temperature of maximum 110 °C.
2. Pre-dry the on-load tap-changer in circulating air at a maximum temperature of 110 °C for a period of at least 20 hours.
3. Vacuum-dry on-load tap-changer at between 105 °C and maximum 125 °C for at least 50 hours.
4. Residual pressure of no more than 10⁻³ bar.



If you wish to perform another transformer ratio test after drying, proceed as described in the section "Performing transformer ratio test following drying" [► Section 5.2.8, Page 65].

5.2.6.2 Vapor-phase drying in the transformer tank

If you have opened the kerosene drain plug already (e.g. after the transformer ratio test), you can begin the drying [► Section 5.2.6.2.4, Page 63] right away.

Otherwise, you first have to open the kerosene drain plug before you can begin the drying.

5.2.6.2.1 Removing diverter switch insert

5.2.6.2.1.1 Moving on-load tap-changer to adjustment position

- Move the on-load tap-changer to the adjustment position. The adjustment position is indicated in the on-load tap-changer connection diagram included in delivery.

5.2.6.2.1.2 Removing on-load tap-changer head cover

⚠ WARNING



Danger of explosion!

Explosive gases under the on-load tap-changer head cover can deflagrate or explode and result in severe injury or death.

- Ensure that there are no ignition sources such as open flames, hot surfaces or sparks (e.g. caused by the build-up of static charge) in the immediate surroundings and that none occur.
- De-energize all auxiliary circuits (for example tap-change supervisory device, pressure relief device, pressure monitoring device) before removing the on-load tap-changer head cover.
- Do not operate any electrical devices during the work (e.g. risk of sparks from impact wrench).

NOTICE

Damage to the on-load tap-changer!

Small parts in the oil compartment may block the diverter switch insert, thereby damaging the on-load tap-changer.

- Ensure that parts do not fall into the oil compartment.
- Check that all small parts are accounted for.

1. Ensure that the inspection window is sealed off with the cover.
2. Remove the screws and washers from the on-load tap-changer head cover.

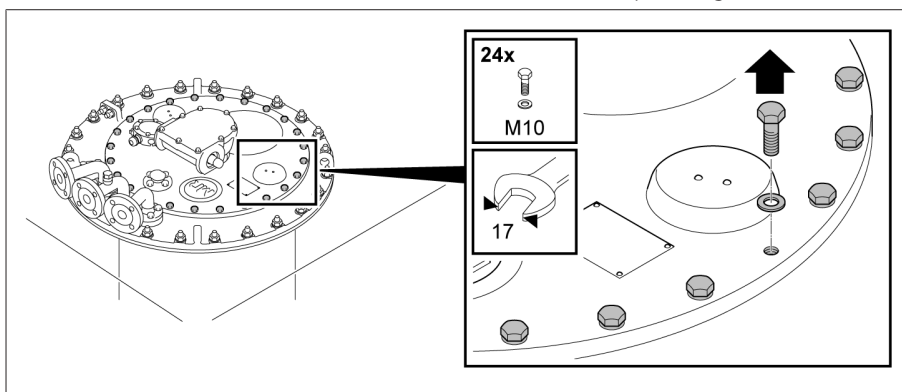

Figure 51: On-load tap-changer head cover

3. Remove on-load tap-changer head cover.

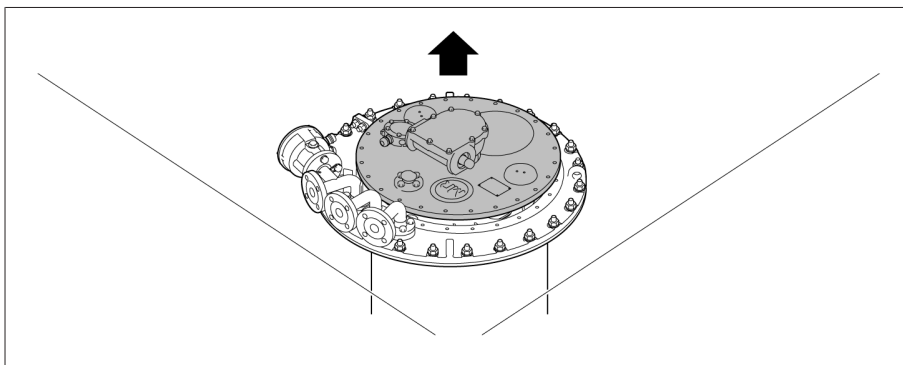

Figure 52: On-load tap-changer head cover

5.2.6.2.1.3 Removing tap position indicator disk without multiple coarse change-over selector

- > Pull spring clip off shaft end and remove tap position indicator disk.

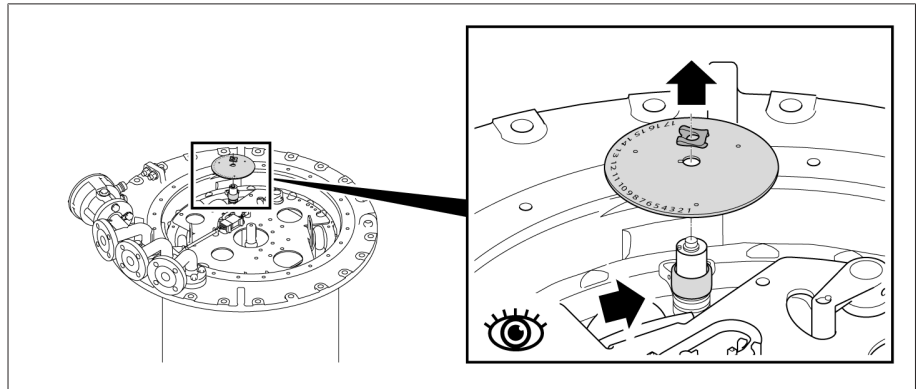

Figure 53: Tap position indicator disk

5.2.6.2.1.4 Removing tap position indicator disk with multiple coarse change-over selector with more than 35 operating positions

1. Ensure that the red marks on the panel, tap position indicator disk and cover disk produce a continuous red line.
2. Remove countersunk head screw.

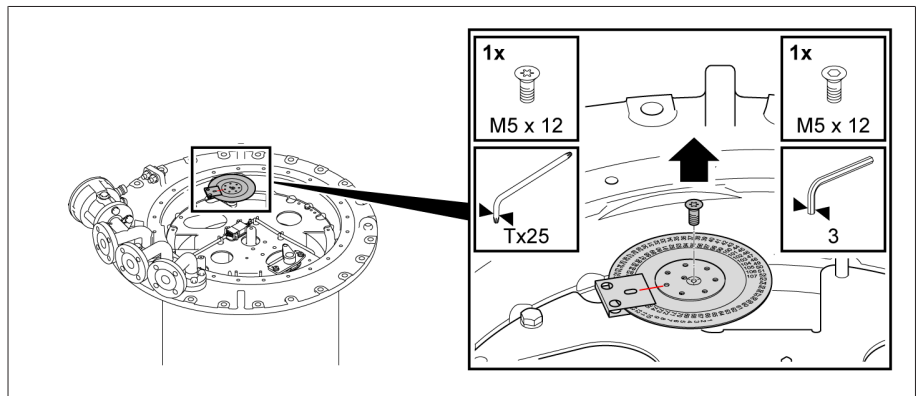

Figure 54: Countersunk head screw

3. Lever cover disk off underlying disk with flat screwdriver and pull out position-indication disk from between panel and bracket.

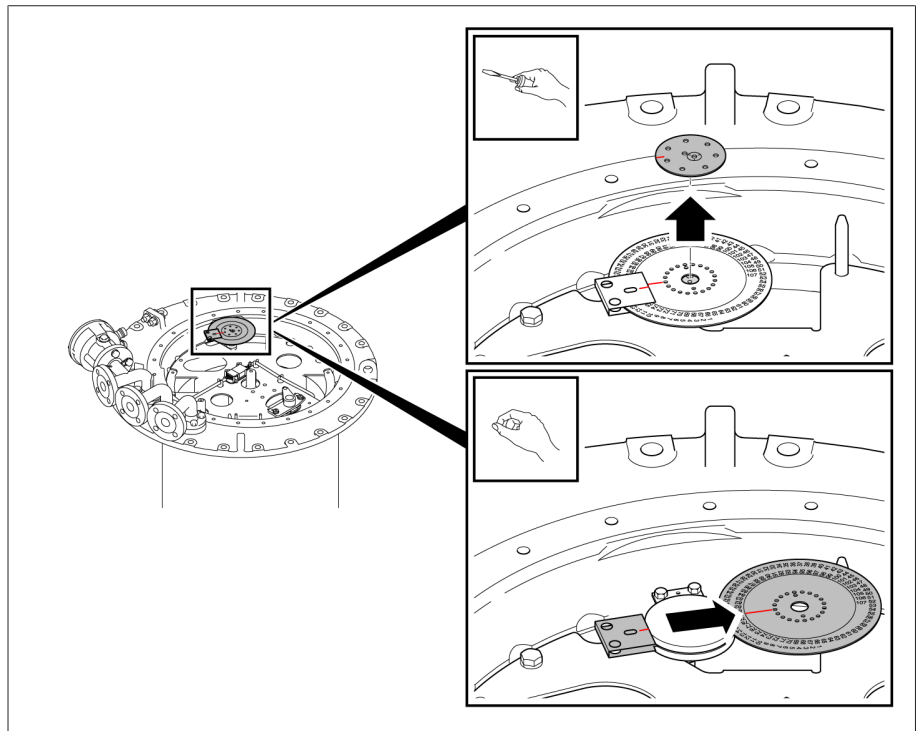

Figure 55: Cover disk and position-indication disk

4. Remove hexagon screws and associated lock tab.

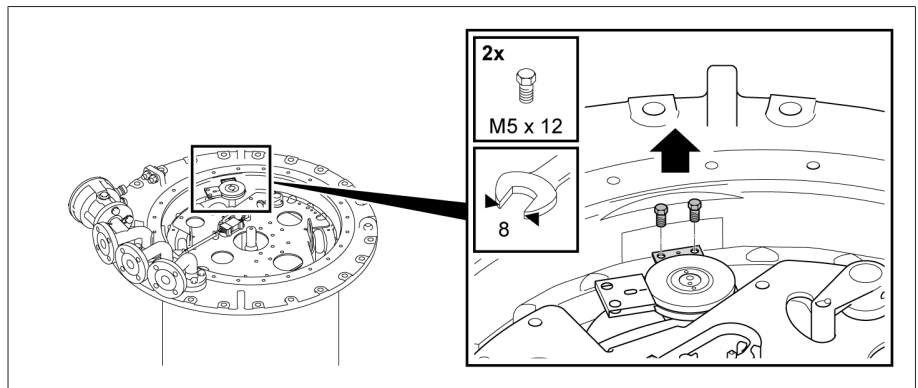

Figure 56: Lock tab

5. Pull panel and bracket up and off indicator drive shaft.

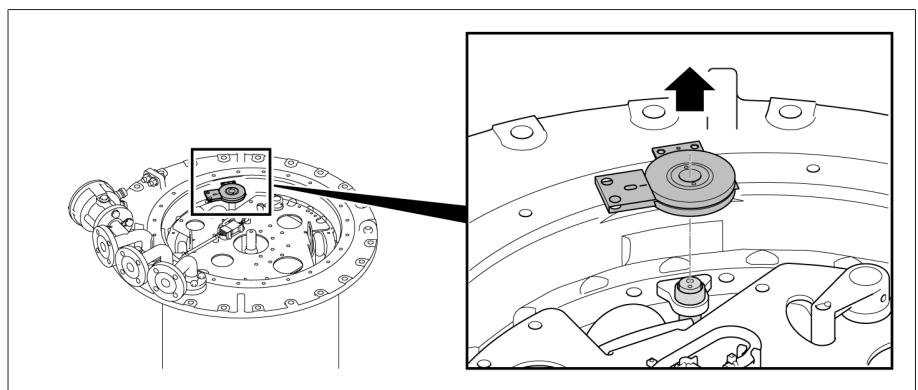

Figure 57: Panel

5.2.6.2.1.5 Disconnecting the plug connector of the tap-change supervisory control

⚠ DANGER



Electric shock!

If supply voltage is applied to the tap-change supervisory device, this can result in electric shock.

- Disconnect the tap-change supervisory device from the supply voltage and secure it to prevent it from being switched back on again.

NOTICE

Damage to the tap-change supervisory device!

Disconnecting the tap-change supervisory device without due care may damage it, thereby resulting in damage to the on-load tap-changer.

- Disconnect the tap-change supervisory device with care in order not to damage or rip out the connecting leads.

1. Lift plug connector and leads out of bracket and retaining clamps.

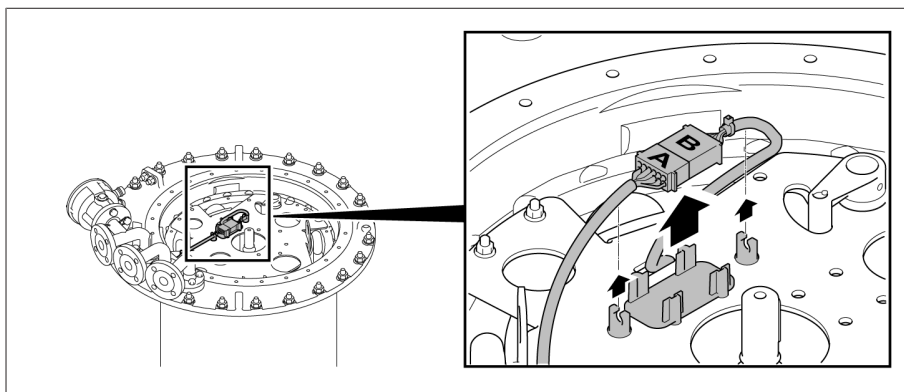

Figure 58: Lifting out plug connector

2. Disconnect the plug connector.

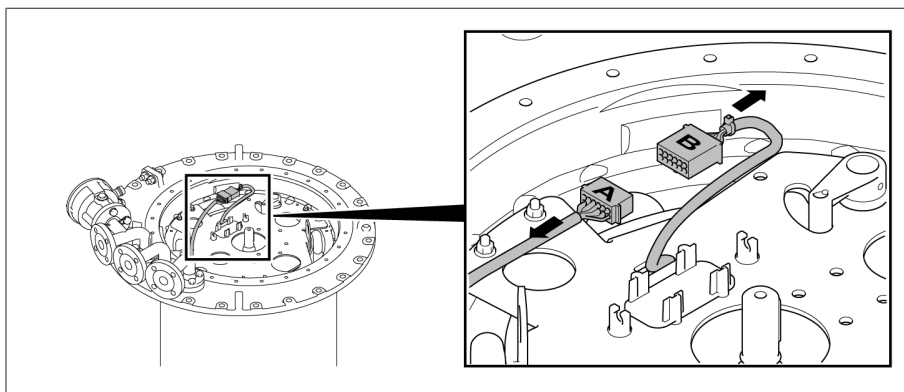

Figure 59: Disconnecting plug connector

3. Put part B of plug connector back in bracket.

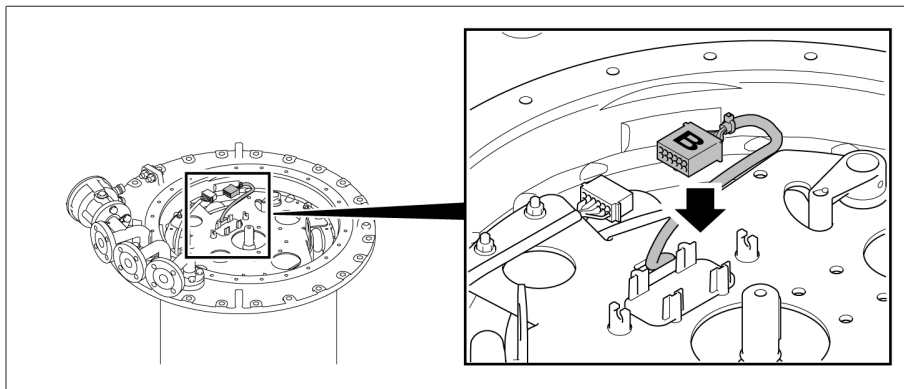

Figure 60: Placing part B of plug connector in bracket

- Swivel part A of plug connector out of on-load tap-changer head in direction indicated by arrow until it is between the pipe connections and the cable cannot be damaged when pulling out the diverter switch insert.

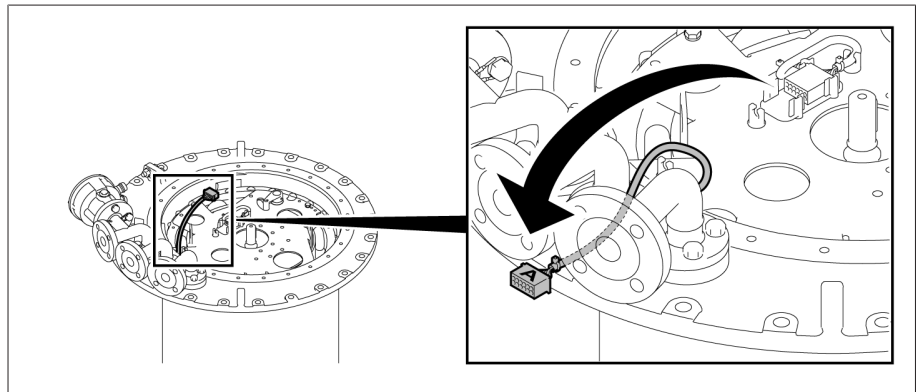

Figure 61: Swiveling out part A of plug connector

5.2.6.2.1.6 Lifting out diverter switch insert

- Remove attachment and locking elements on carrier plate of diverter switch insert.

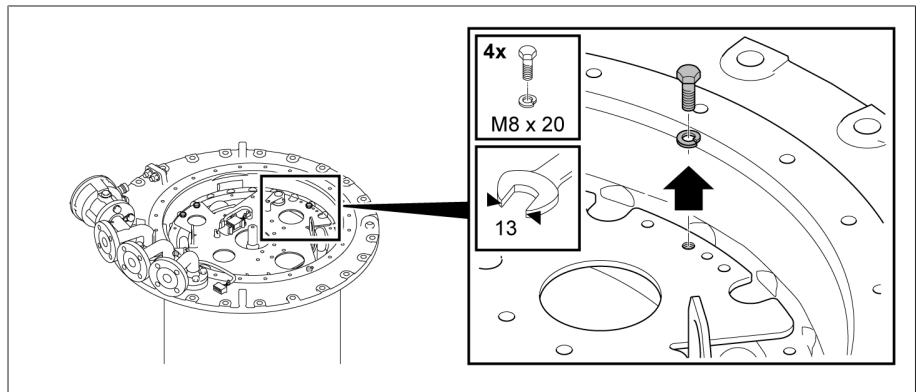

Figure 62: Carrier plate of diverter switch insert

- Insert lifting gear in the brackets on the diverter switch insert carrier plate and position vertically above the diverter switch insert.

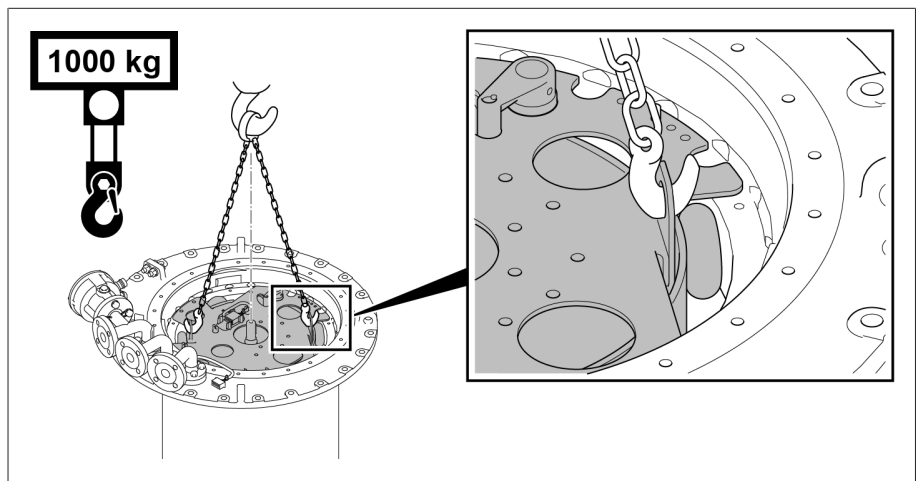

Figure 63: Brackets on carrier plate

3. Lift out diverter switch insert slowly and vertically.

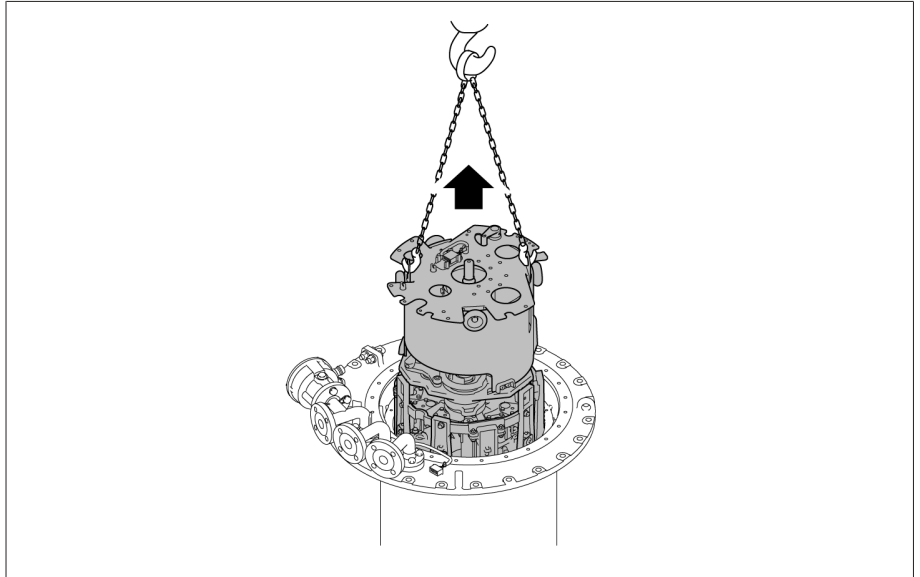

Figure 64: Lifting out diverter switch insert

4. **⚠ CAUTION!** An unstably positioned diverter switch insert may tip, resulting in injuries and property damage. Place the diverter switch insert on a level surface and secure it against tipping.
5. Note down whether the diverter switch insert is in the final end position on side A or side B. The vacuum interrupter is closed on the side that is in the final end position. In the example in the appendix, side B is in the final end position.

5.2.6.2.2 Opening kerosene drain plug

- > **NOTICE!** Never remove the kerosene drain plug completely. Unscrew kerosene drain plug with extended socket wrench counter-clockwise until it starts to become hard to open.

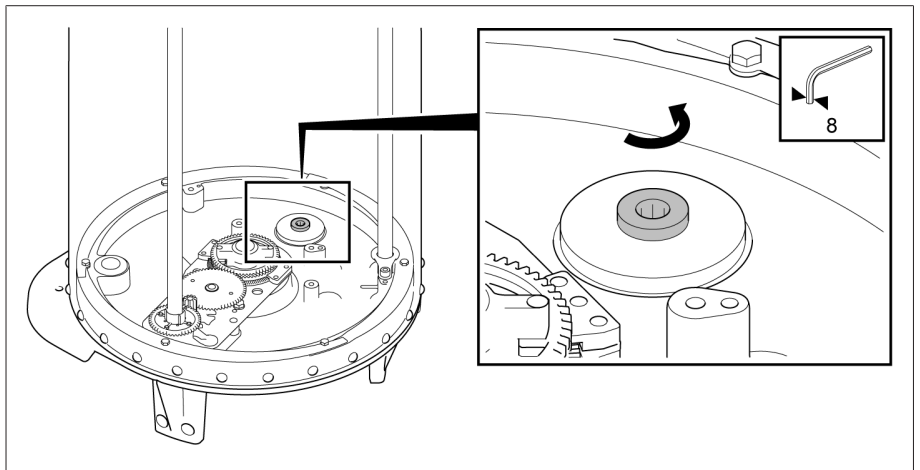

Figure 65: Kerosene drain plug

5.2.6.2.3 Inserting diverter switch insert

5.2.6.2.3.1 Inserting diverter switch insert

1. To fit diverter switch insert, ensure that selector coupling and indicator gear are in the adjustment position.

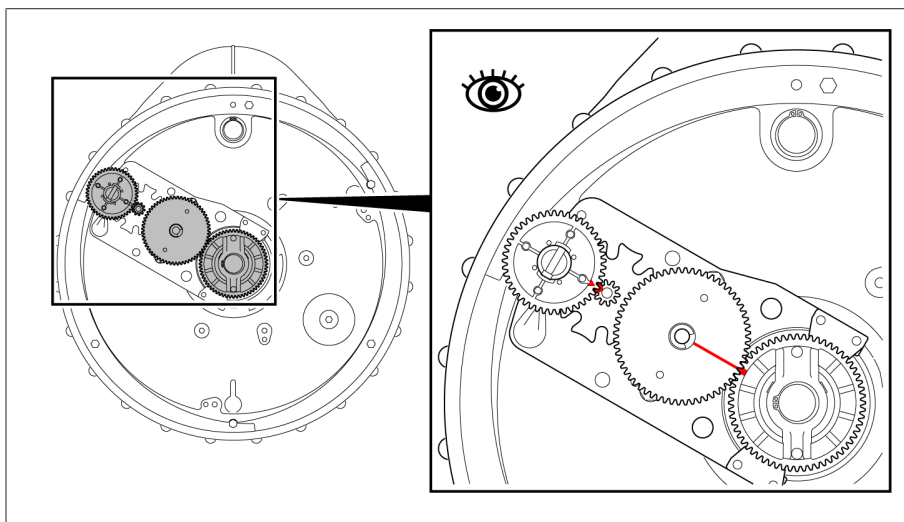

Figure 66: Adjustment position

2. Insert lifting gear in the brackets provided on the diverter switch insert carrier plate and position vertically above the diverter switch insert.

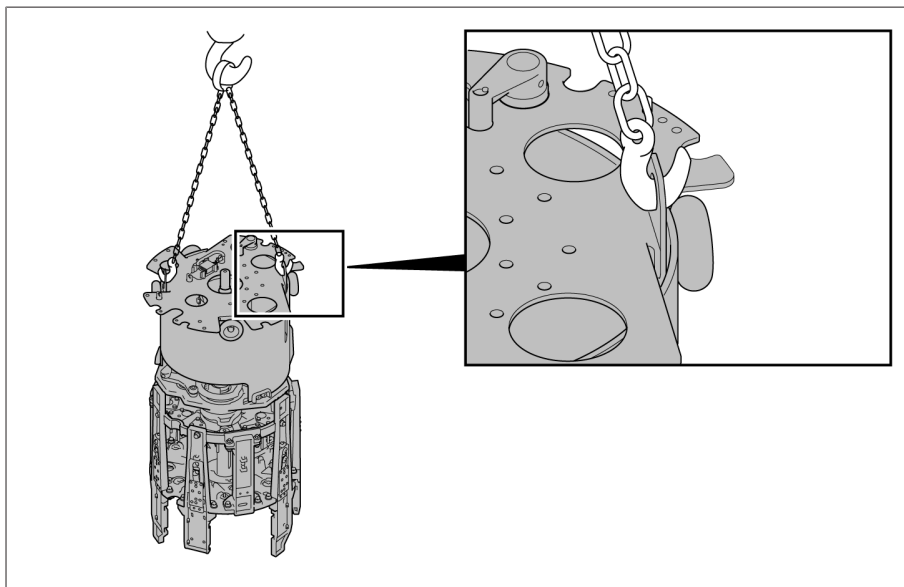

Figure 67: Brackets on carrier plate

3. Ensure that diverter switch insert is in the final end position on the same side as when it was removed (side A or side B). The vacuum interrupter is closed on the side that is in the final end position. In the example in the appendix, side B is in the final end position, see appendix.

- By turning the coupling tube, align it in such a manner that the red triangles on the coupling tube and carrier plate match up.

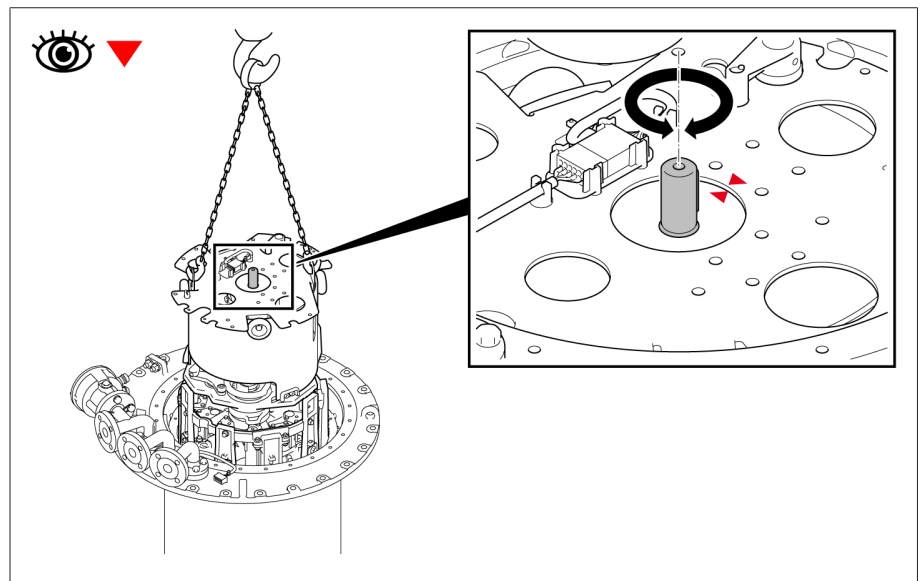

Figure 68: Coupling tube

- NOTICE!** Mixing up the diverter switch inserts will lead to damage to the on-load tap-changer. Ensure the same number of triangles on the top of the energy accumulator and on-load tap-changer head.
- Align diverter switch insert such that the red triangles at the top of the energy accumulator and on the on-load tap-changer head are opposite one another. Slowly lower diverter switch insert.

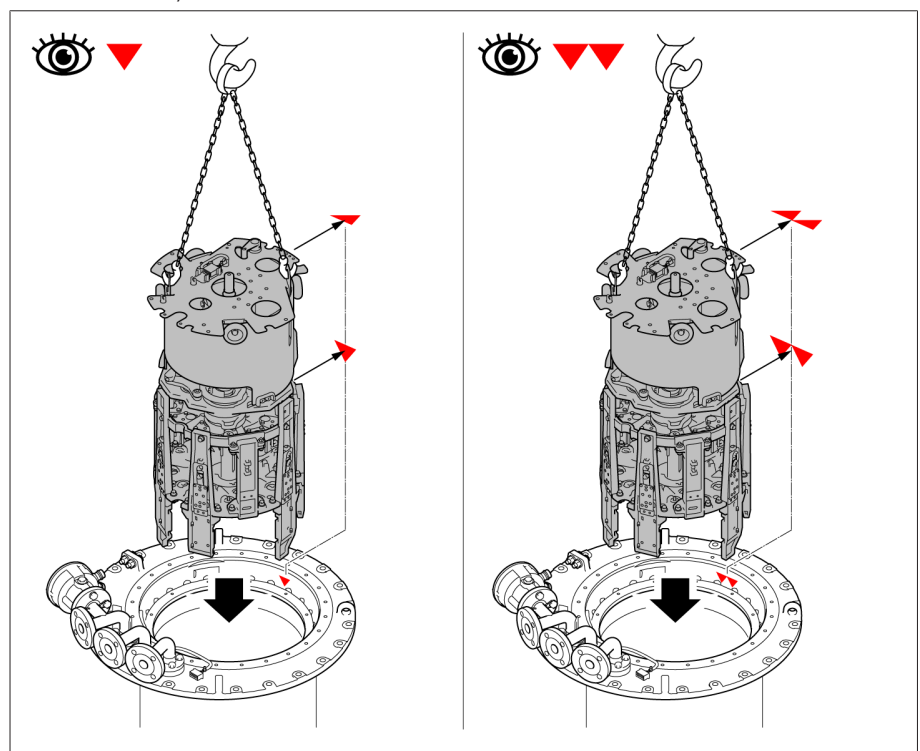

Figure 69: Aligning diverter switch insert

- Ensure correct position of carrier plate in on-load tap-changer head. Area marked red must remain free.

8. Secure carrier plate of diverter switch insert.

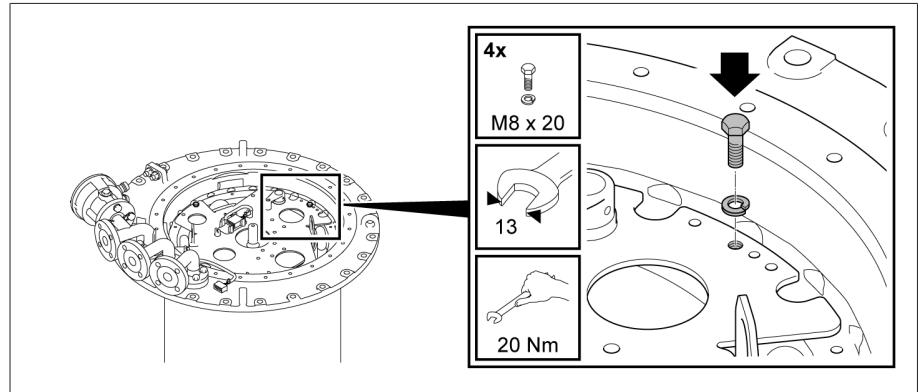

Figure 70: Carrier plate of diverter switch insert

5.2.6.2.3.2 Connecting plug connector of the tap-change supervisory device

1. Lift part B of plug connector out of bracket.

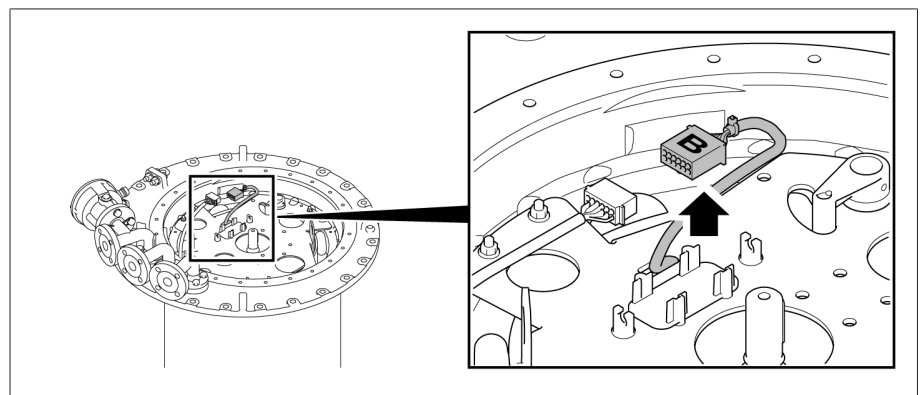

Figure 71: Part B of plug connector

2. Connecting plug connector

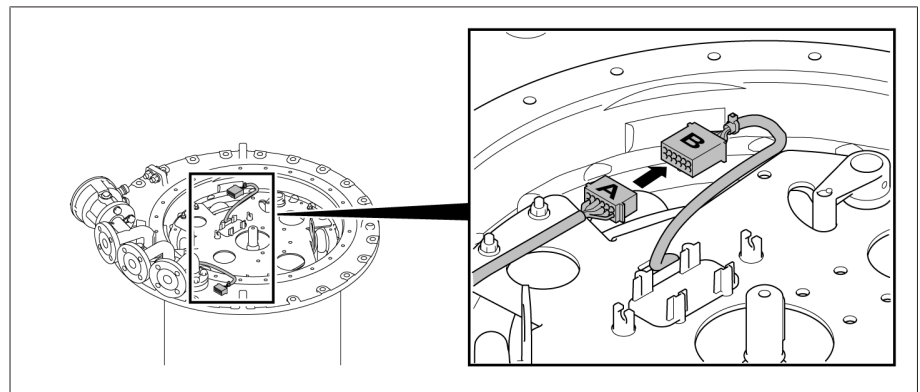

Figure 72: Connecting plug connector

- Place plug connector in bracket, secure leads on both sides of plug connector in retaining clamps.

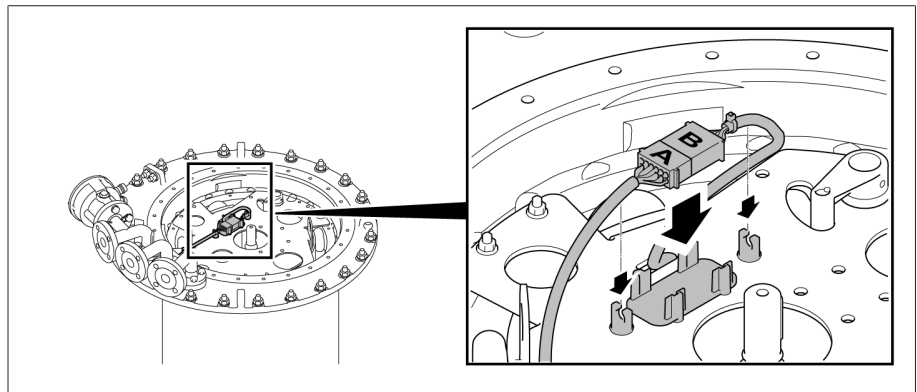

Figure 73: Placing plug connector in bracket

5.2.6.2.3.3 Inserting the tap position indicator without multiple coarse change-over selector



Due to the coupling pin, the tap position indicator disc can only be installed when in the correct position.

- Place tap position indicator disk on indicator drive shaft, slide spring clip on to shaft end.

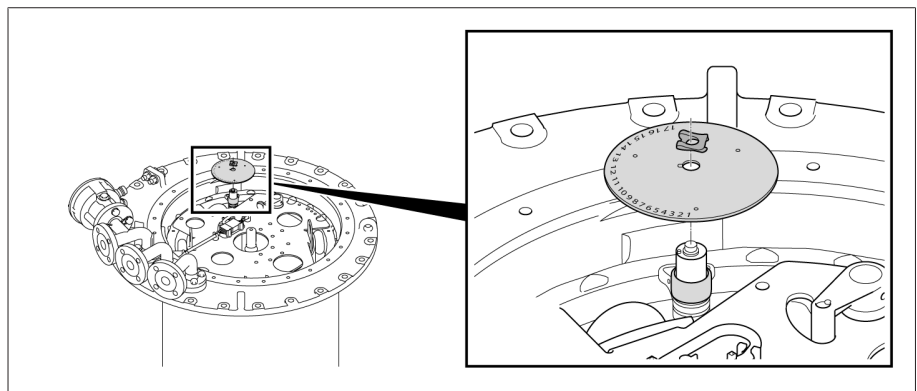

Figure 74: Tap position indicator disk

5.2.6.2.3.4 Inserting tap position indicator with multiple coarse change-over selector with more than 35 operating positions

- Place panel with bracket on indicator drive shaft and fasten with hexagon screws and associated lock tab.

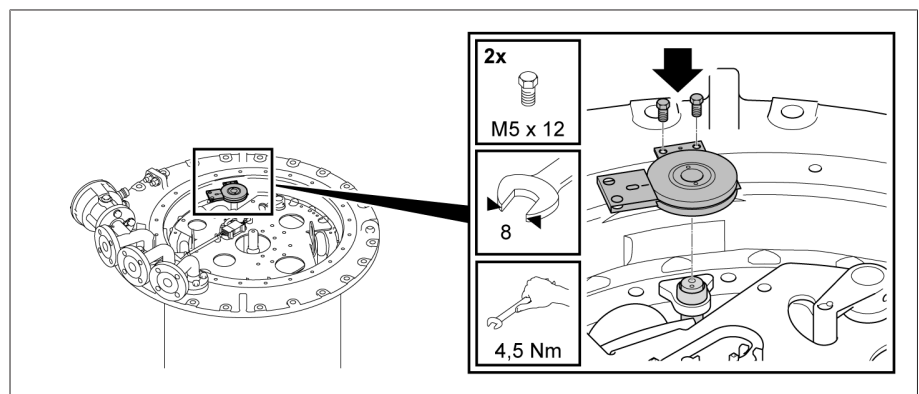

Figure 75: Fitting panel

2. Insert position-indication disk horizontally between panel and bracket and fit cover disk. Align tap position indicator disc and cover disk to produce a continuous red line.

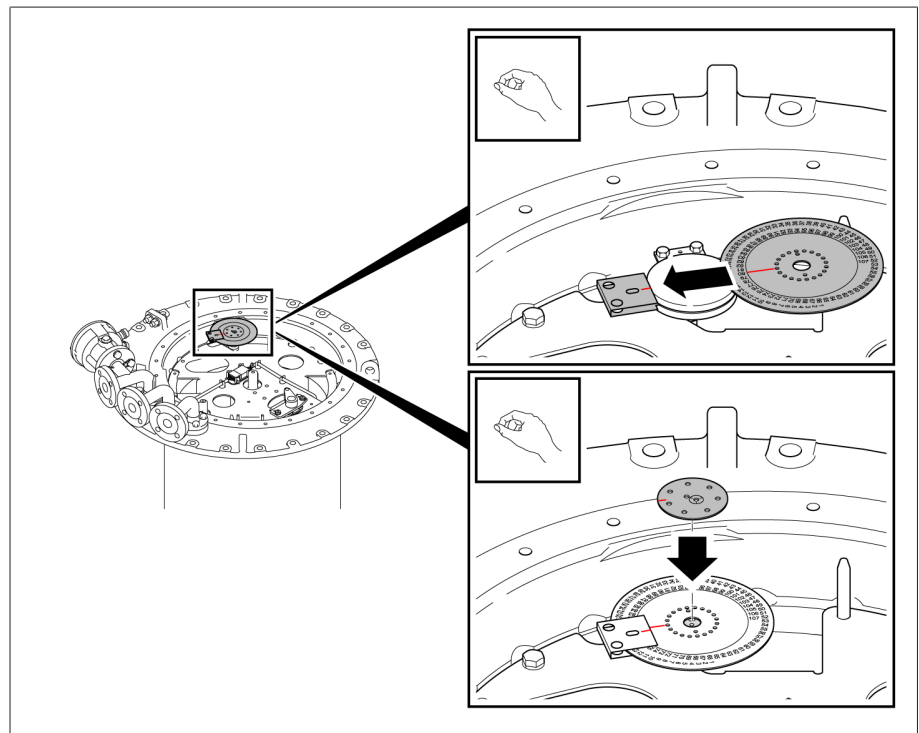

Figure 76: Inserting position-indication disk

3. Secure cover disk with countersunk head screw. The countersunk head screw must be suitable for center-punching.

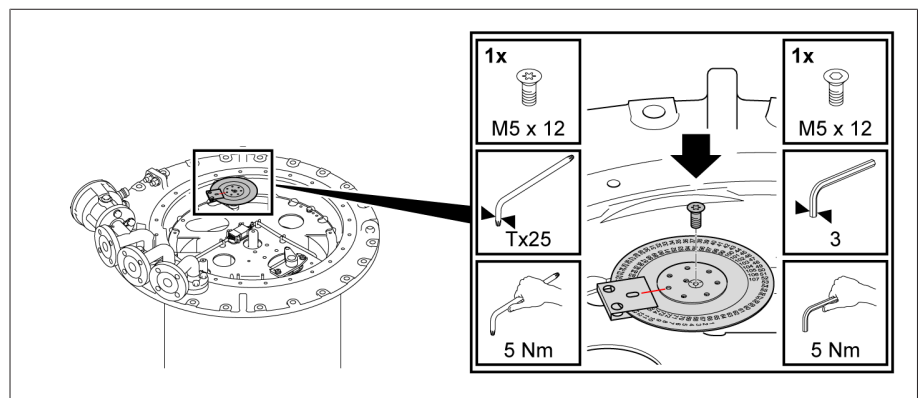

Figure 77: Fastening cover disk

4. Secure countersunk head screw by center-punching.

5.2.6.2.3.5 **NOTICE** Securing on-load tap-changer head cover Damage to the on-load tap-changer!

A missing or damaged o-ring as well as unclean sealing surfaces lead to insulating fluid escaping and therefore to damage to the on-load tap-changer.

- > Ensure that the o-ring is positioned untwisted in the on-load tap-changer head cover.
- > Ensure that the o-ring does not become damaged when mounting the cover.
- > Ensure that the sealing surfaces on the on-load tap-changer head cover and on-load tap-changer head are clean.

1. Check that the feather key is securely positioned in the adapter shaft. Where necessary, use Vaseline to secure the feather key against falling out.

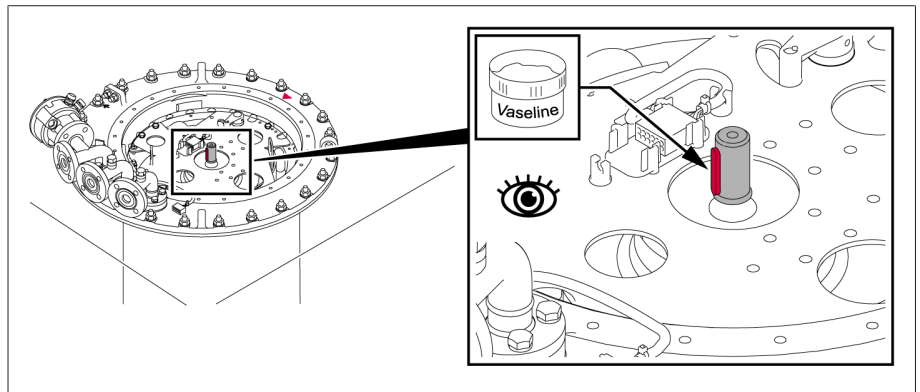

Figure 78: Feather key

2. Position the on-load tap-changer head cover on the on-load tap-changer head in such a way that the red triangular markings on the on-load tap-changer head and the on-load tap-changer head cover are aligned.

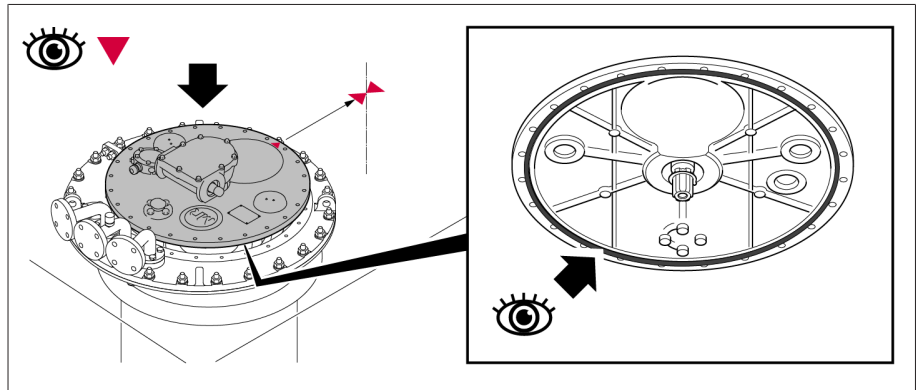

Figure 79: Triangular markings and o-ring

3. Screw the on-load tap-changer head cover onto the on-load tap-changer head.

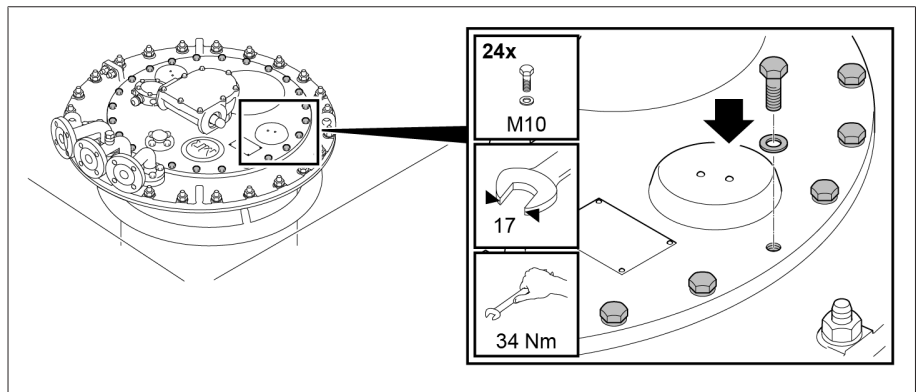

Figure 80: On-load tap-changer head cover

5.2.6.2.4 Drying the on-load tap-changer

1. Connect pipe connections R and Q of on-load tap-changer head to the kerosene vapor lead using one shared lead.
2. Seal off unused pipe connections with a suitable blank cover.

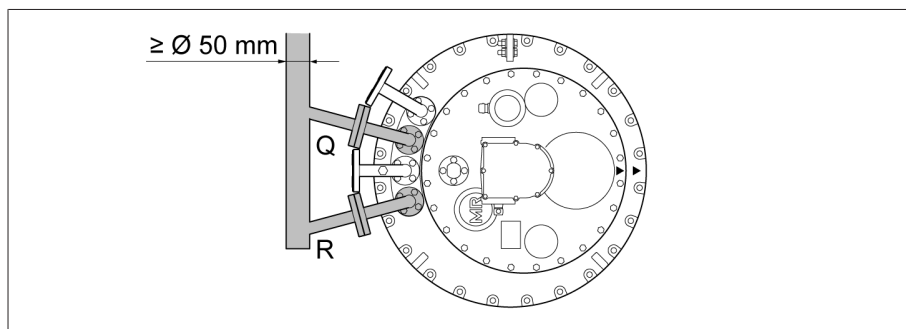

Figure 81: Shared lead

Vapor-phase drying in the transformer tank

1. Supply kerosene vapor at a temperature of around 90°C. Keep this temperature constant for 3 to 4 hours.
2. Increase the kerosene vapor temperature by approx. 10°C/hour to the desired final temperature of max. 125°C at the on-load tap-changer.
3. Vacuum-dry on-load tap-changer at between 105°C and maximum 125°C for at least 50 hours.
4. Residual pressure of no more than 10⁻³ bar.

5.2.6.2.5 Closing kerosene drain plug

NOTICE

Damage to the on-load tap-changer!

Moisture in the oil compartment reduces the dielectric strength of the insulating fluid and thus leads to damage to the on-load tap-changer.

- > Within 10 hours of drying, seal off oil compartment with on-load tap-changer head cover.

1. Remove [▶ Section 5.2.6.2.1, Page 51] the diverter switch insert.
2. **NOTICE!** An open kerosene drain plug leads to insulating fluid escaping from the oil compartment and therefore to damage to the on-load tap-changer. Close kerosene drain plug by turning clockwise with extended socket wrench (tightening torque 20 Nm).
3. Insert [▶ Section 5.2.6.2.3, Page 57] the diverter switch insert.



If you wish to perform another transformer ratio test after drying, proceed as described in the section "Performing transformer ratio test following drying" [▶ Section 5.2.8, Page 65].

5.2.7 Filling the oil compartment of the on-load tap-changer with insulating fluid

NOTICE

Damage to the on-load tap-changer!

Unsuitable insulating fluids cause damage to the on-load tap-changer.

- > Only use insulating fluids [▶ Section 8.1.2, Page 198] approved by the manufacturer.

After drying, completely fill the oil compartment (diverter switch insert fitted) with insulating fluid again as soon as possible so that an impermissible amount of humidity is not absorbed from the surroundings.

1. Establish a connecting lead between pipe connection E2 and one of the pipe connections R, S or Q to ensure equal pressure in the oil compartment and transformer during evacuation.

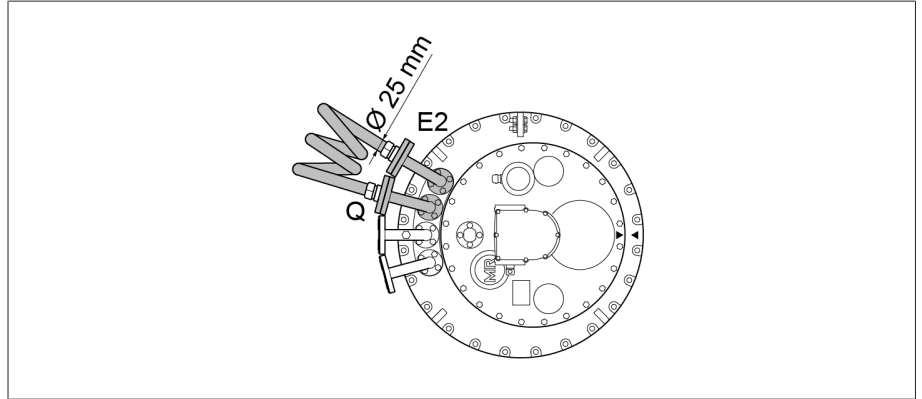

Figure 82: Connecting lead between E2 and Q

2. Fill on-load tap-changer with new insulating fluid using one of the two free pipe connections of the on-load tap-changer head.

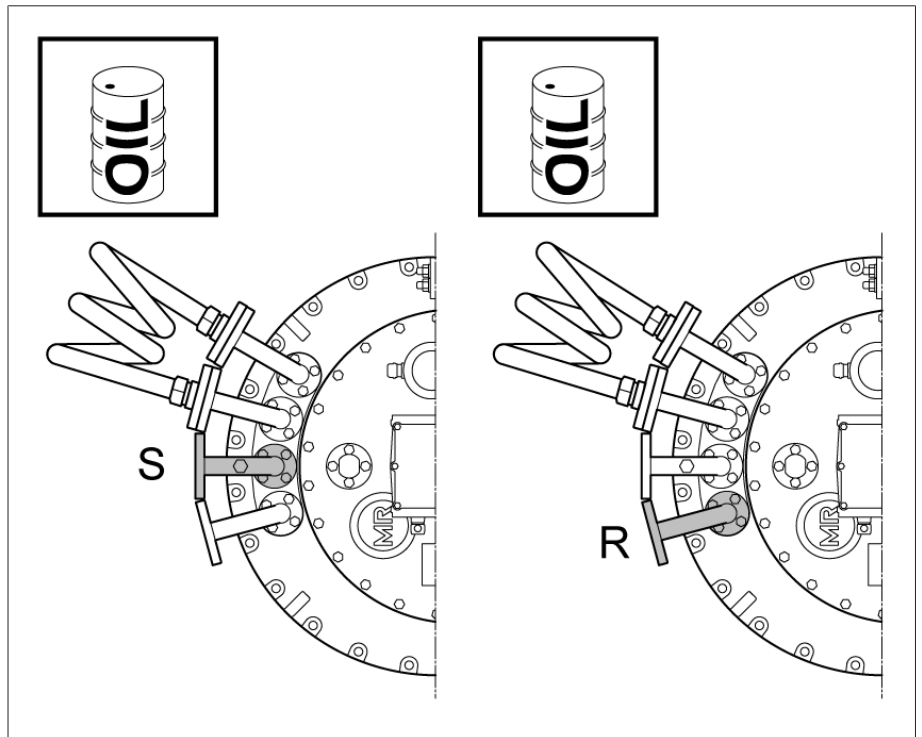

Figure 83: Pipe connections S and R

5.2.8 Performing transformer ratio test after drying Damage to the on-load tap-changer!

Damage to the on-load tap-changer due to transformer ratio test being incorrectly performed.

- Ensure that the selector / de-energized tap changer is fully immersed in the insulating fluid and that the oil compartment of the on-load tap-changer is completely filled with insulating fluid.
- Only switch the on-load tap-changer from one operating position to the next via the upper gear unit. You can use a short tube (diameter 25 mm) with screwed-in coupling bolt (diameter 12 mm) with a hand wheel or crank for this, for example. When using a drill, do not exceed a maximum speed of 250 rpm.
- Always check the operating position reached through the inspection window in the on-load tap-changer head cover. Never overshoot the end positions, which are indicated in the connection diagram supplied with the delivery.
- For multiple-column applications with a shared drive, link all on-load tap-changer heads to one another using the horizontal drive shaft part.



When actuating the change-over selector, a higher torque is required.

1. Switch the on-load tap-changer into the desired operating position. The diverter switch operation can be heard distinctly.
2. **NOTICE!** An incomplete tap-change operation may damage the on-load tap-changer. After operating the diverter switch, continue to crank the drive shaft of the upper gear unit for 2.5 revolutions in the same direction in order to correctly complete the tap-change operation.
3. Perform the transformer ratio test.
4. Repeat the transformer ratio test in all operating positions.
5. Switch the on-load tap-changer into adjustment position (see the accompanying connection diagram for the on-load tap-changer).

5.3 Installing on-load tap-changer in transformer (bell-type tank version)

5.3.1 Inserting on-load tap-changer into supporting structure

5.3.1.1 Securing selector on oil compartment

1. **⚠ CAUTION!** An unstably positioned selector may tip, resulting in injuries or property damage. Place the selector on a level surface and secure it against tipping.
2. Remove red-colored packaging material and transport material from the selector. Only remove the red protective cap on the O-bar of the change-over selector after inserting the on-load tap-changer into the supporting structure.
3. Remove plastic bag with fastening materials from the selector and keep it ready.

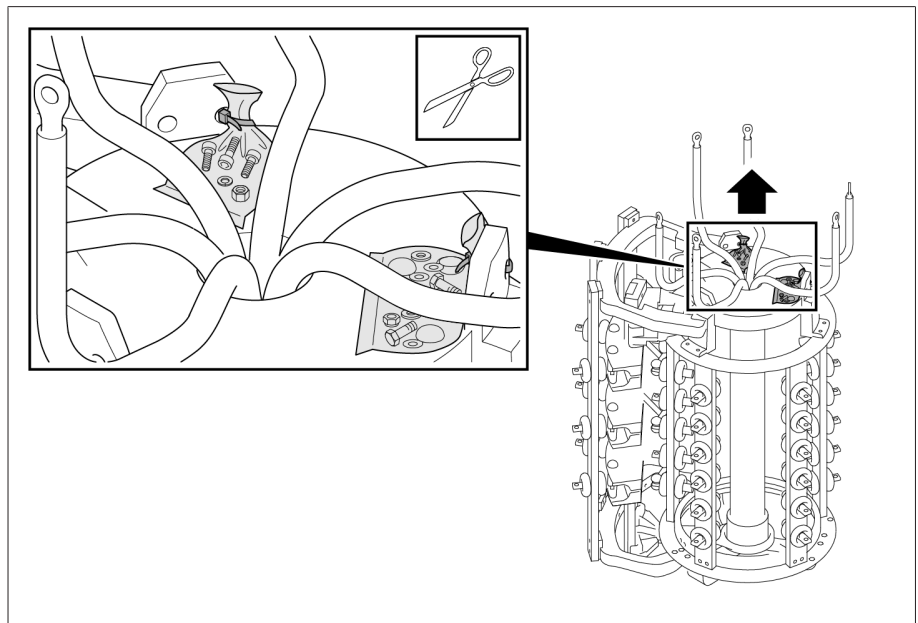

Figure 84: Plastic bag with fastening materials

4. Remove the blocking strip from the selector coupling. Once the blocking strip is removed, the selector coupling may no longer be turned.

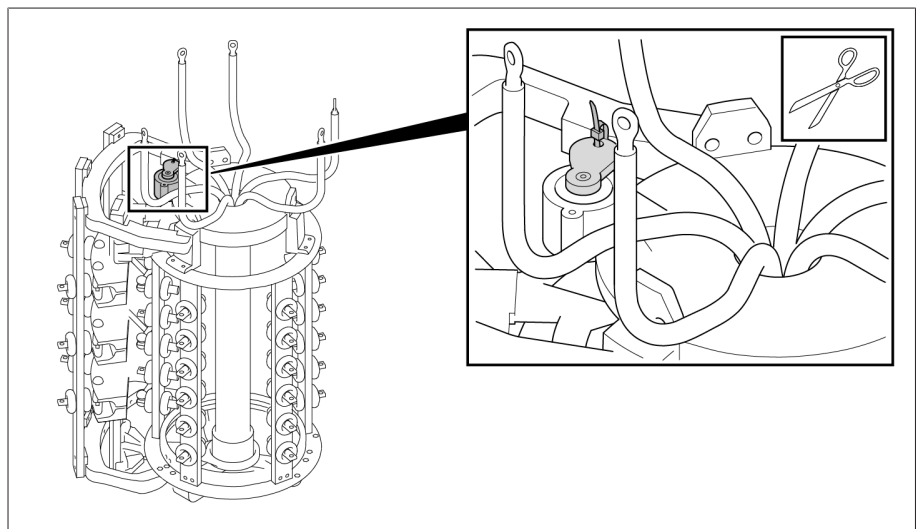

Figure 85: Selector coupling with blocking strip

5. **⚠ CAUTION!** An unstably positioned oil compartment may tip over, resulting in injuries or property damage. Place the oil compartment on a level surface and secure it against tipping.
6. Remove the blocking strip from the coupling of the oil compartment base.

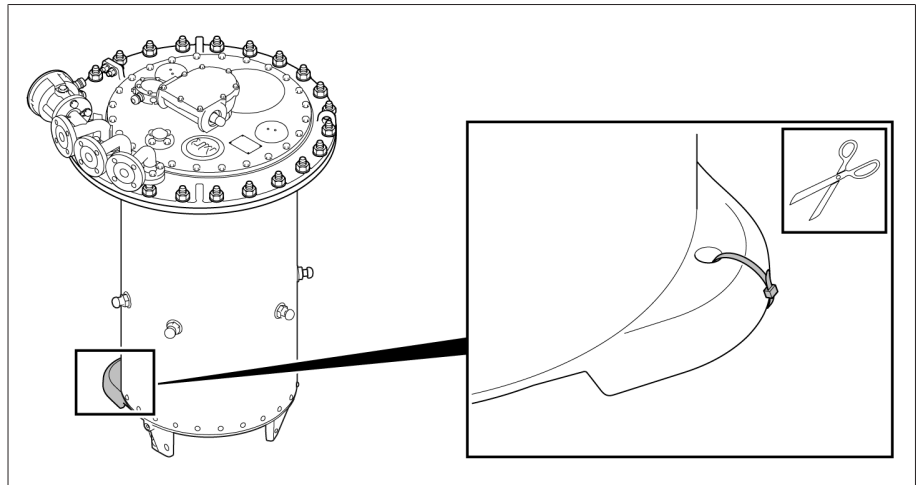

Figure 86: Oil compartment base with blocking strip

7. Lift the oil compartment by hooking up the on-load tap-changer head and carefully move it over the selector. The weight of the oil compartment is a maximum of 320 kg.
8. **NOTICE!** Lowering the oil compartment without due care can result in the oil compartment and selector colliding and becoming damaged. Carefully lower the oil compartment, ensuring that the tap-selector connecting leads and potential connection unit (if installed) are free when lifting the selector onto the oil compartment, and that they do not touch the compartment.
9. Align the position of both coupling parts and attachment points on the oil compartment and the selector with one another. The correct position of the two coupling parts is shown in the adjustment plans supplied.
10. Screw selector onto oil compartment.

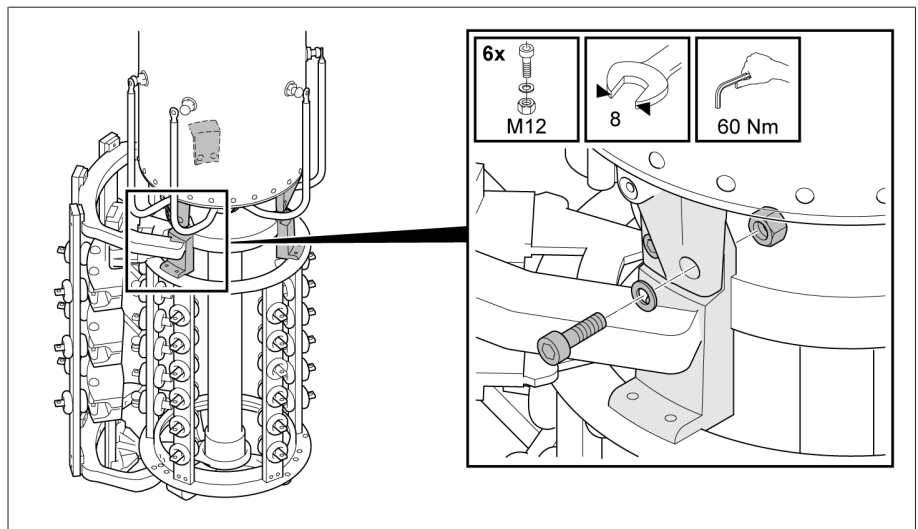

Figure 87: Selector with oil compartment

11. **NOTICE!** Incorrect tightening torques and unsecured screw connections can lead to damage to the on-load tap-changer. Screw the tap-selector connecting leads to connecting piece with care. Comply with the specified tightening torque, secure screw connections and snap the screening caps in place over the screw heads.

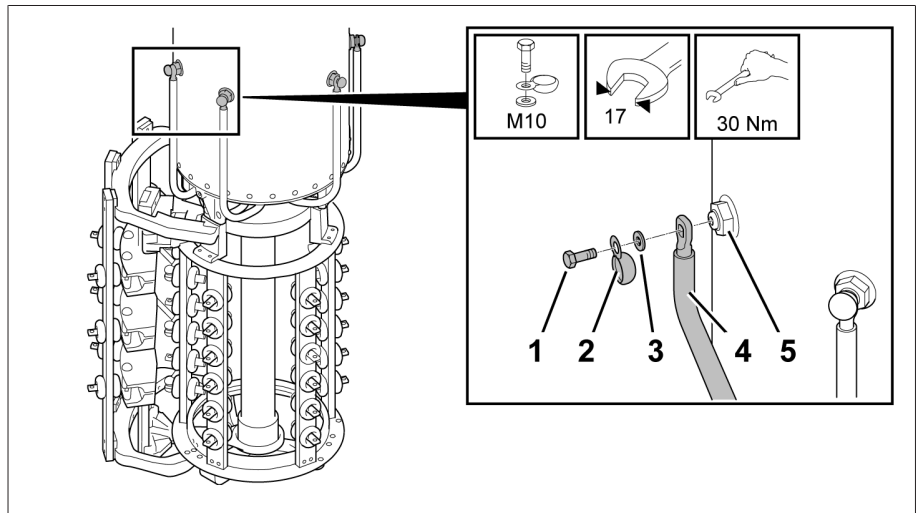

Figure 88: Tap-selector connecting leads

5.3.1.2 Inserting on-load tap-changer into supporting structure

1. **NOTICE!** Tensile forces can lead to damage and malfunctions on the on-load tap-changer. Using spacers, insert the on-load tap-changer vertically into the supporting structure (maximum 1° deviation from the vertical) so that the on-load tap-changer reaches its final installation height and only has to be raised a maximum of 5...20 mm once the tap winding and the on-load tap-changer take-off lead have been connected and the bell-type tank fitted.

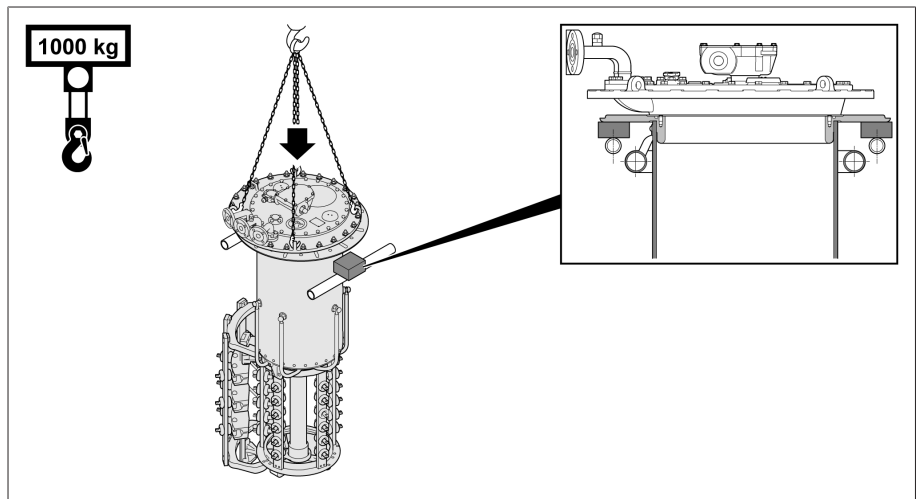

Figure 89: On-load tap-changer with spacers on supporting structure

2. Temporarily fasten on-load tap-changer to supporting structure. The supporting flange has through holes for this purpose.

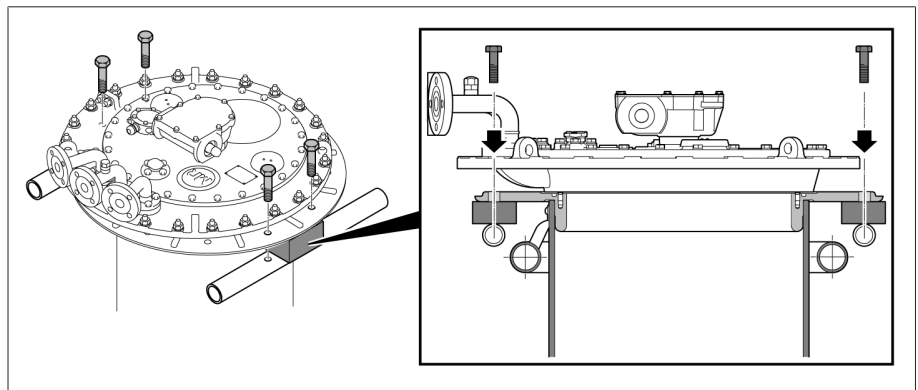

Figure 90: Fastening the on-load tap-changer

3. Remove the red protective cap on the 0-bar of the change-over selector (if present).

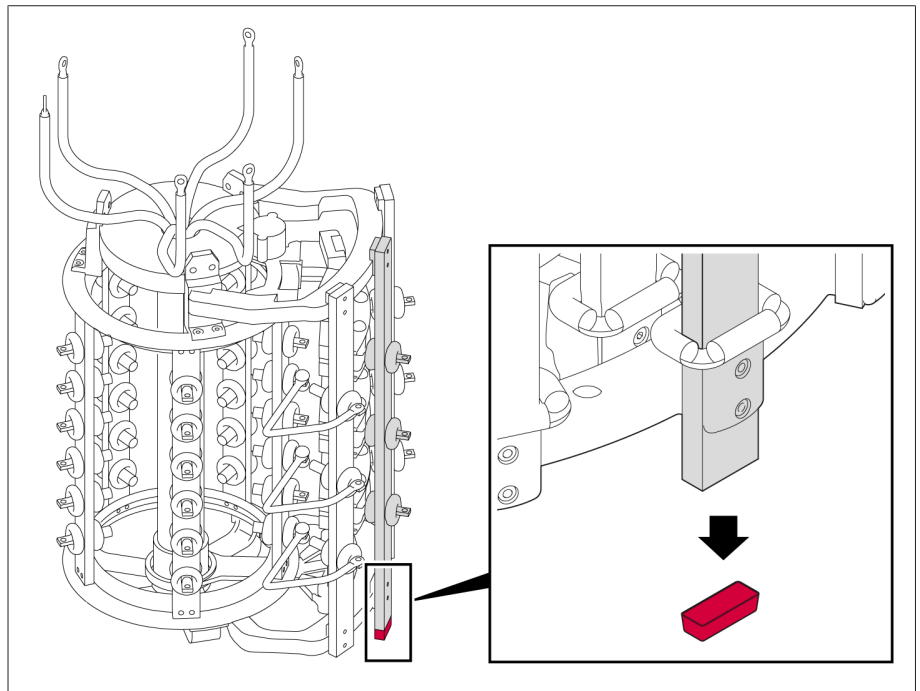

Figure 91: Protective cap

4. Secure selector with pitch of tap selector contact circle 36 to prevent it twisting as a result of being turned and slid. There are 3 holes, 20 mm in diameter, in the selector base for this purpose. Ensure that it can still be slid in an axial direction.



The selector's pitch of tap selector contact circle is stated in the on-load tap-changer's type designation after the selector size.
Example: M I 501-123/B-36340 (B = selector size, 36 = pitch of tap selector contact circle)

5.3.2 Connecting the tap winding and on-load tap-changer take-off lead

NOTICE

Damage to the on-load tap-changer!

Connecting leads that place mechanical strain on the on-load tap-changer will damage the on-load tap-changer.

- > Establish connections carefully.
- > Do not twist connection contacts.
- > Connect connecting leads without warping or deforming.
- > If necessary, use an expansion loop for connecting leads.
- > Fit screening caps provided to screw connections.

The tap winding and on-load tap-changer take-off lead must be connected in accordance with the connection diagram included with the delivery.

5.3.2.1 Tap selector connection contacts

The tap selector connection contacts are provided with a through-hole for M10 screws. The through-holes are either horizontal or vertical, depending on the on-load tap-changer model.

1. Fasten the tap-winding connecting leads to the tap selector in accordance with the connection diagram provided. The cable shoes and fastening materials are not included in the scope of delivery.
2. Take suitable measures to ensure that each screw connection cannot come loose or settle (e.g. by using clamping washers). Be sure to attach the screening caps as shown in the illustration if these are included in the delivery scope.
3. Close the screening caps and make sure they are seated correctly. The screw head and nut must be fully covered.

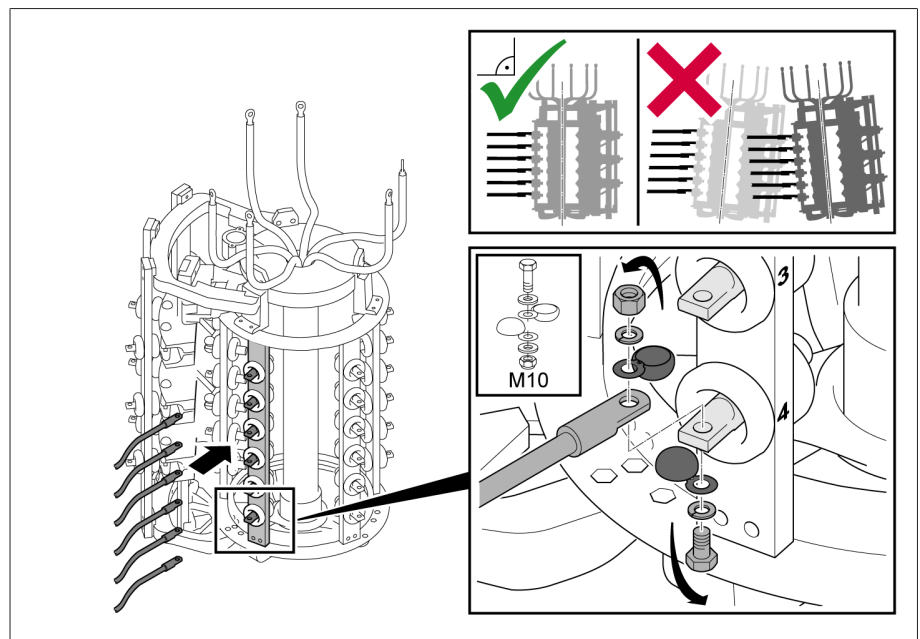

Figure 92: Tap selector connection contacts

5.3.2.2 Tap selector connection contacts for multiple coarse tapping arrangement

NOTICE

Damage to the on-load tap-changer!

Tap-winding connecting leads situated too closely to the change-over selector's moving parts block the change-over selector and therefore result in damage to the on-load tap-changer.

- > Tap-winding connecting leads in the area of the change-over selector have to be routed such that they are at a sufficient distance from the change-over selector's moving parts.

In the case of multiple coarse change-over selectors, take care when routing the cables for connecting to the tap selector connection contacts and the multiple coarse change-over selector connection contacts. These cables should be as far away as possible from neighboring connection contacts.

1. The tap selector connection contacts that face both multiple coarse change-over selector columns must have at least 3 mm of paper insulation to ensure dielectric strength.
2. Please pay attention to the dimensional drawing on which the order is based.

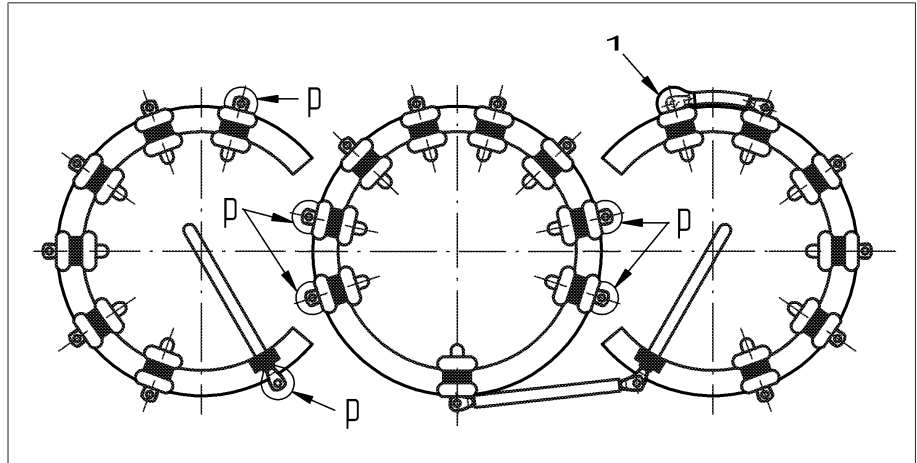

Figure 93: Paper insulation

1	Connection from MR already has 3 mm of paper insulation	p	Connections to be insulated
---	---	---	-----------------------------

5.3.2.3 Change-over selector connection contacts for reversing change-over selector connection

NOTICE

Damage to the on-load tap-changer!

Tap-winding connecting leads situated too closely to the change-over selector's moving parts block the change-over selector and therefore result in damage to the on-load tap-changer.

- > Tap-winding connecting leads in the area of the change-over selector have to be routed such that they are at a sufficient distance from the change-over selector's moving parts.

The (+) and (-) change-over selector connection contacts are designed as connecting lugs with through-holes for M10 screws for reversing change-over selector connection.

The connection contact K is designed as an extended tap selector connection contact with through-hole for M10 screws.

1. Fasten the tap-winding connecting leads to the change-over selector in accordance with the connection diagram provided. The cable shoes and fastening materials are not included in the scope of delivery.
2. Take suitable measures to ensure that each fitting cannot come loose or settle (e.g. by using clamping washers). Be sure to attach the screening caps if these are included in the delivery scope.

3. Close the screening caps and make sure they are seated correctly. The screw head and nut must be fully covered.

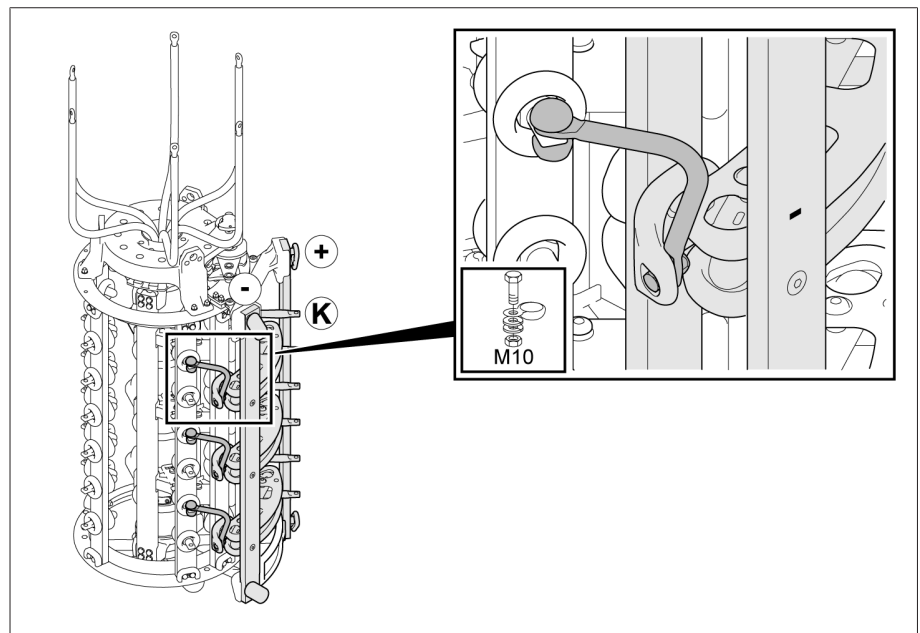

Figure 94: Change-over selector connection contacts for reversing change-over selector connection

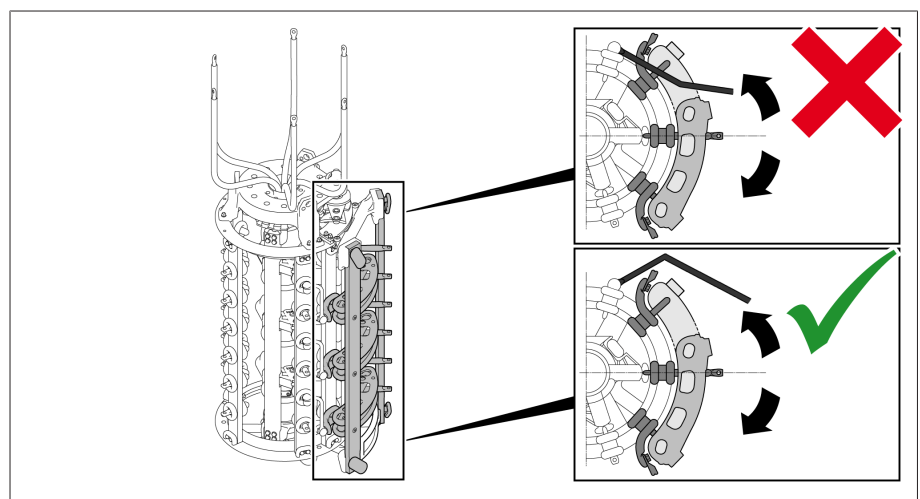

Figure 95: Change-over selector connection contacts for reversing change-over selector connection (top view)

5.3.2.4 Change-over selector connection contacts for coarse tap selector connection

NOTICE

Damage to the on-load tap-changer!

Tap-winding connecting leads situated too closely to the change-over selector's moving parts block the change-over selector and therefore result in damage to the on-load tap-changer.

- > Tap-winding connecting leads in the area of the change-over selector have to be routed such that they are at a sufficient distance from the change-over selector's moving parts.

With coarse tap selector connection, the external appearance of the (+) and (-) change-over selector connection contacts is identical to the tap selector contacts (through-hole for M10 screws, always in vertical position).

1. Fasten the tap-winding connecting leads to the change-over selector in accordance with the connection diagram provided. The cable shoes and fastening materials are not included in the scope of delivery.
2. Take suitable measures to ensure that each fitting cannot come loose or settle (e.g. by using clamping washers). Be sure to attach the screening caps if these are included in the delivery scope.
3. Close the screening caps and make sure they are seated correctly. The screw head and nut must be fully covered.

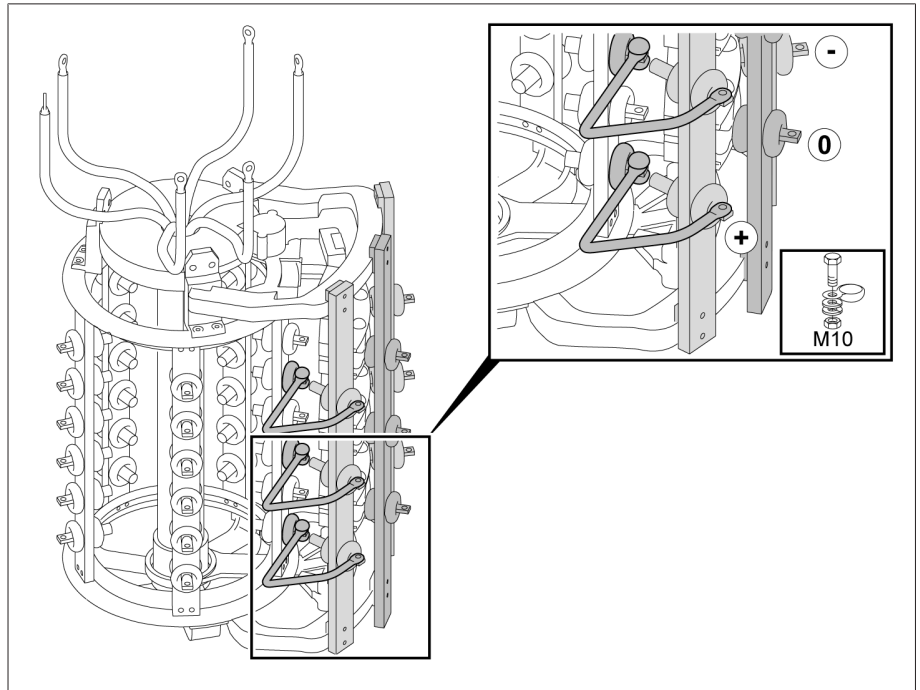

Figure 96: Change-over selector connection contacts for coarse tap selector connection

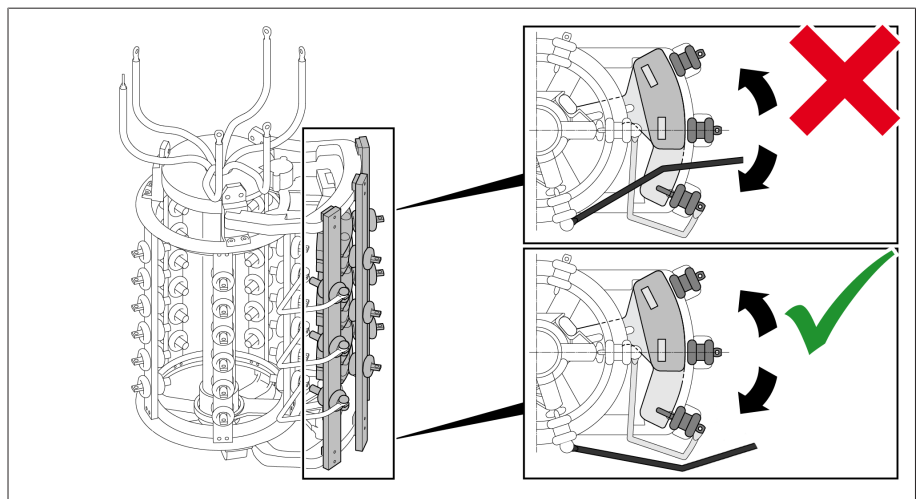

Figure 97: Change-over selector connection contacts for coarse tap selector connection (top view)

5.3.2.5 Change-over selector connection contacts for multiple coarse tapping arrangement

NOTICE

Damage to the on-load tap-changer!

Tap-winding connecting leads situated too closely to the change-over selector's moving parts block the change-over selector and therefore result in damage to the on-load tap-changer.

- > Tap-winding connecting leads in the area of the change-over selector have to be routed such that they are at a sufficient distance from the change-over selector's moving parts.

With a multiple coarse tapping arrangement, the external appearance of the change-over selector connection contacts is identical to the tap selector contacts (through-hole for M10 screws, always in vertical position).

1. Fasten the tap-winding connecting leads to the change-over selector in accordance with the connection diagram provided. The cable shoes and fastening materials are not included in the scope of delivery.
2. Take suitable measures to ensure that each fitting cannot come loose or settle (e.g. by using clamping washers). Be sure to attach the screening caps if these are included in the delivery scope.
3. Close the screening caps and make sure they are seated correctly. The screw head and nut must be fully covered.

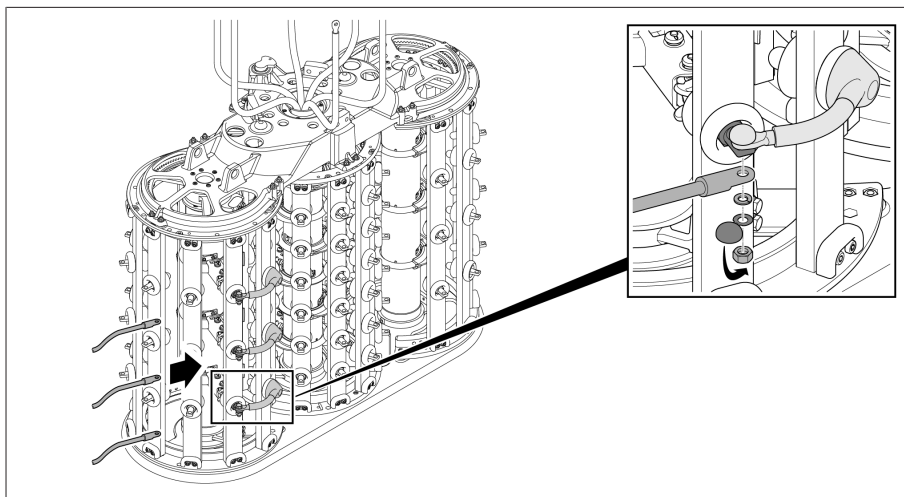

Figure 98: Change-over selector connection contacts for multiple coarse tapping arrangement

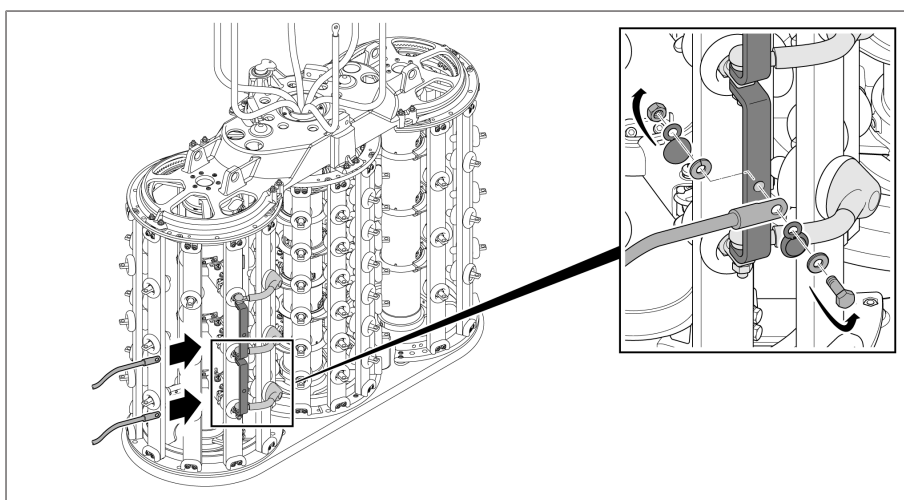

Figure 99: Change-over selector connection contacts for multiple coarse tapping arrangement with bridges on the connection contacts

5.3.2.6 Connecting on-load tap-changer take-off lead

5.3.2.6.1 Take-off lead connection directly on oil compartment

1. Connect the on-load tap-changer take-off lead to the take-off lead connection using the cable shoe and screw. The cable shoe and fastening materials are not included in the scope of delivery.
2. Take suitable measures to ensure the screw connection cannot come loose or settle (e.g. by using clamping washers).

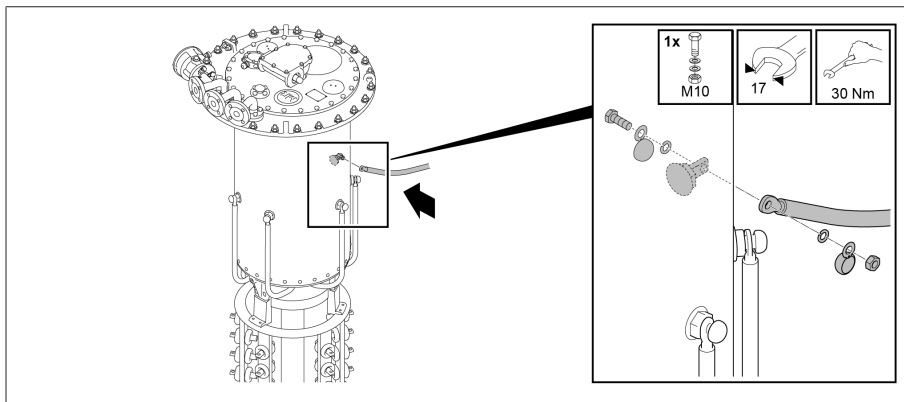

Figure 100: Take-off lead connection on oil compartment

5.3.2.6.2 Take-off lead connection on take-off ring

1. Connect the on-load tap-changer take-off lead to 1 of the 3 through-holes on the take-off ring using a cable shoe and screw. The cable shoe and fastening materials are not included in the scope of delivery.
2. Pay attention to the screw length. A minimum distance of 2 mm must be maintained between screw and oil compartment.

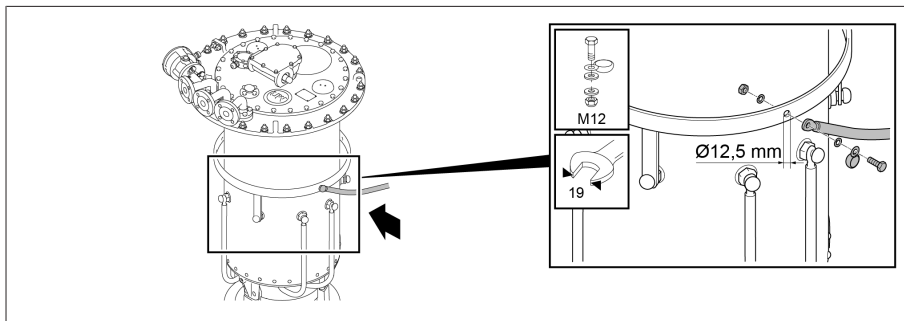

Figure 101: Connecting ring of oil compartment

3. Take suitable measures to ensure the screw connection cannot come loose or settle (e.g. by using clamping washers).

NOTICE

5.3.3 Performing transformer ratio test before drying Damage to the on-load tap-changer!

Damage to the on-load tap-changer due to transformer ratio test being incorrectly performed.

- › Do not perform more than 250 tap-change operations on the on-load tap-changer. If more than 250 tap-change operations are to be performed, completely fill the oil compartment with insulating fluid and lubricate sliding surfaces of contacts on the selector and selector gear with insulating fluid.
- › Only switch the on-load tap-changer from one operating position to the next via the upper gear unit. You can use a short tube (diameter 25 mm) with screwed-in coupling bolt (diameter 12 mm) with a hand wheel or crank for this, for example. When using a drill, do not exceed a maximum speed of 250 rpm.
- › Always check the operating position reached through the inspection window in the on-load tap-changer head cover. Never overshoot the end positions, which are indicated in the connection diagram supplied with the delivery.
- › For multiple-column applications with a shared drive, link all on-load tap-changer heads to one another using the horizontal drive shaft parts.



When actuating the change-over selector, a higher torque is required.

1. Switch the on-load tap-changer into the desired operating position. The diverter switch operation can be heard distinctly.
2. **NOTICE!** An incomplete tap-change operation may damage the on-load tap-changer. After operating the diverter switch, continue to crank the drive shaft of the upper gear unit for 2.5 revolutions in the same direction in order to correctly complete the tap-change operation.
3. Perform the transformer ratio test.
4. Repeat the transformer ratio test in all operating positions.
5. Switch the on-load tap-changer into adjustment position (see the accompanying connection diagram for the on-load tap-changer).



After the transformer ratio test, open the kerosene drain plug in the oil compartment if the on-load tap-changer is to be dried with kerosene in the transformer tank. After drying, the diverter switch insert must be removed, the kerosene drain plug in the oil compartment closed and the diverter switch insert refitted.

NOTICE

5.3.4 Performing DC resistance measurement on transformer Damage to the on-load tap-changer.

Excessive measurement currents overload the contacts of the on-load tap-changer and thus cause damage to the on-load tap-changer.

- › Ensure that the maximum permissible measurement currents specified in the following table are not exceeded.

- › Perform the DC resistance measurement in various on-load tap-changer operating positions in accordance with the following table.

Status of oil compartment	Without interruption of the measured current	With interruption (measured current = 0 A before change of operating position)
Oil compartment empty	Maximum 10 A DC	Maximum 50 A DC
Oil compartment filled with insulating fluid	Maximum 50 A DC	Maximum 50 A DC

Table 5: Maximum permitted measured currents when performing DC resistance measurement on transformer

NOTICE

5.3.5 Drying on-load tap-changer in autoclave Damage to the on-load tap-changer!

Moisture in the oil compartment reduces the dielectric strength of the insulating fluid and thus leads to damage to the on-load tap-changer.

- > Within 10 hours of drying, seal off oil compartment with on-load tap-changer head cover.

Dry on-load tap-changer in accordance with the following instructions to ensure the dielectric values assured by MR for the on-load tap-changer.

If drying in an autoclave, the following methods are possible:

- Vacuum drying
- Vapor-phase drying

As an alternative to drying the on-load tap-changer in an autoclave, it can also be dried in the transformer tank.

5.3.5.1 Vacuum-drying in the autoclave



If you wish to perform another transformer ratio test after drying, proceed as described in the section "Performing transformer ratio test following drying" [▶ Section 5.3.10, Page 117].

5.3.5.1.1 Moving on-load tap-changer to adjustment position

- > Move the on-load tap-changer to the adjustment position. The adjustment position is indicated in the on-load tap-changer connection diagram included in delivery.

5.3.5.1.2 Removing on-load tap-changer head cover

⚠ WARNING



Danger of explosion!

Explosive gases under the on-load tap-changer head cover can deflagrate or explode and result in severe injury or death.

- > Ensure that there are no ignition sources such as open flames, hot surfaces or sparks (e.g. caused by the build-up of static charge) in the immediate surroundings and that none occur.
- > De-energize all auxiliary circuits (for example tap-change supervisory device, pressure relief device, pressure monitoring device) before removing the on-load tap-changer head cover.
- > Do not operate any electrical devices during the work (e.g. risk of sparks from impact wrench).

NOTICE

Damage to the on-load tap-changer!

Small parts in the oil compartment may block the diverter switch insert, thereby damaging the on-load tap-changer.

- > Ensure that parts do not fall into the oil compartment.
- > Check that all small parts are accounted for.

1. Ensure that the inspection window is sealed off with the cover.
2. Remove the screws and washers from the on-load tap-changer head cover.

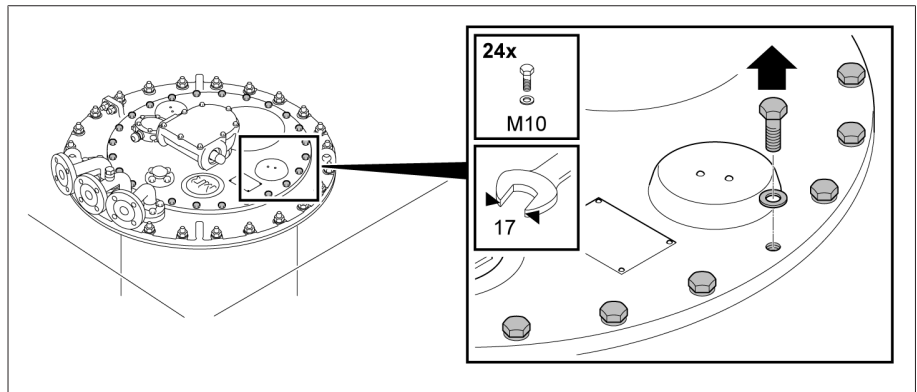

Figure 102: On-load tap-changer head cover

3. Remove on-load tap-changer head cover.

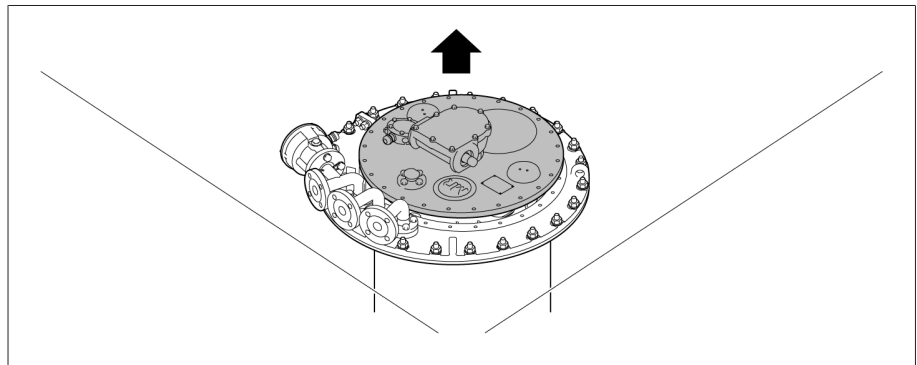

Figure 103: On-load tap-changer head cover

5.3.5.1.3 Drying the on-load tap-changer

NOTICE

Damage to the on-load tap-changer head cover and on-load tap-changer accessories.

Both the on-load tap-changer head cover and the on-load tap-changer accessories will become damaged if they are dried.

› Never dry the on-load tap-changer head cover or the following accessories: motor-drive unit, drive shaft, protective relay, pressure monitoring device, pressure relief device, bevel gear, sensors such as temperature and humidity sensors or pressure sensors, oil filter unit.

1. Heat up the on-load tap-changer in air at atmospheric pressure with a temperature increase of approximately 10 °C/h to a final temperature of maximum 110 °C.
2. Pre-dry the on-load tap-changer in circulating air at a maximum temperature of 110 °C for a period of at least 20 hours.
3. Vacuum-dry on-load tap-changer at between 105 °C and maximum 125 °C for at least 50 hours.
4. Residual pressure of no more than 10⁻³ bar.

5.3.5.1.4 Securing on-load tap-changer head cover

NOTICE

Damage to the on-load tap-changer!

A missing or damaged o-ring as well as unclean sealing surfaces lead to insulating fluid escaping and therefore to damage to the on-load tap-changer.

- Ensure that the o-ring is positioned untwisted in the on-load tap-changer head cover.
- Ensure that the o-ring does not become damaged when mounting the cover.
- Ensure that the sealing surfaces on the on-load tap-changer head cover and on-load tap-changer head are clean.

1. Check that the feather key is securely positioned in the adapter shaft. Where necessary, use Vaseline to secure the feather key against falling out.

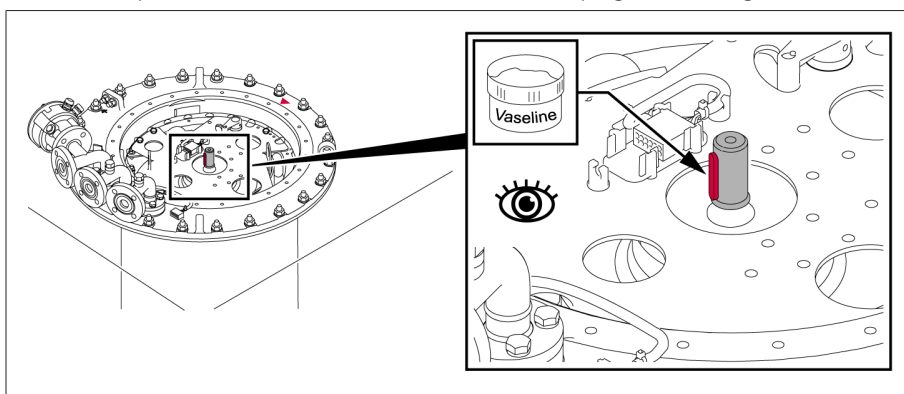

Figure 104: Feather key

2. Position the on-load tap-changer head cover on the on-load tap-changer head in such a way that the red triangular markings on the on-load tap-changer head and the on-load tap-changer head cover are aligned.

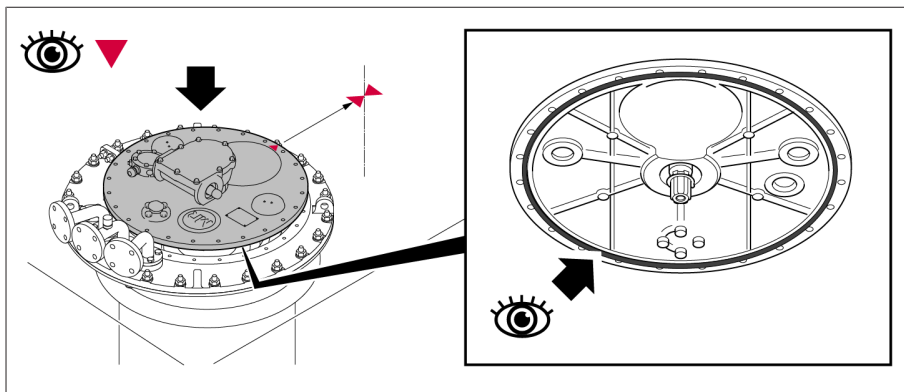

Figure 105: Triangular markings and o-ring

3. Screw the on-load tap-changer head cover onto the on-load tap-changer head.

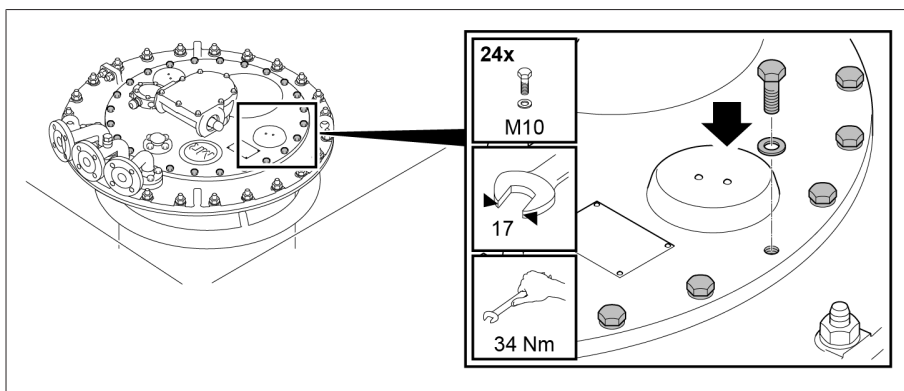

Figure 106: On-load tap-changer head cover

5.3.5.2 Vapor-phase drying in the autoclave



If you wish to perform another transformer ratio test after drying, proceed as described in the section "Performing transformer ratio test following drying" [► Section 5.3.10, Page 117].

5.3.5.2.1 Moving on-load tap-changer to adjustment position

- Move the on-load tap-changer to the adjustment position. The adjustment position is indicated in the on-load tap-changer connection diagram included in delivery.

5.3.5.2.2 Removing on-load tap-changer head cover

⚠ WARNING



Danger of explosion!

Explosive gases under the on-load tap-changer head cover can deflagrate or explode and result in severe injury or death.

- Ensure that there are no ignition sources such as open flames, hot surfaces or sparks (e.g. caused by the build-up of static charge) in the immediate surroundings and that none occur.
- De-energize all auxiliary circuits (for example tap-change supervisory device, pressure relief device, pressure monitoring device) before removing the on-load tap-changer head cover.
- Do not operate any electrical devices during the work (e.g. risk of sparks from impact wrench).

NOTICE

Damage to the on-load tap-changer!

Small parts in the oil compartment may block the diverter switch insert, thereby damaging the on-load tap-changer.

- Ensure that parts do not fall into the oil compartment.
- Check that all small parts are accounted for.

1. Ensure that the inspection window is sealed off with the cover.
2. Remove the screws and washers from the on-load tap-changer head cover.

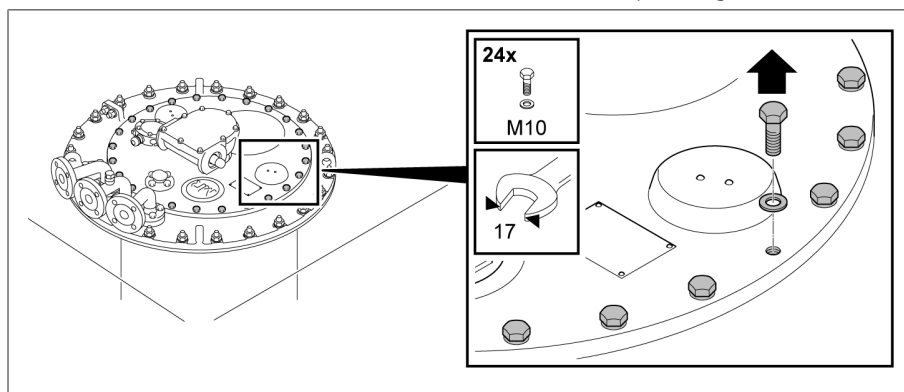

Figure 107: On-load tap-changer head cover

3. Remove on-load tap-changer head cover.

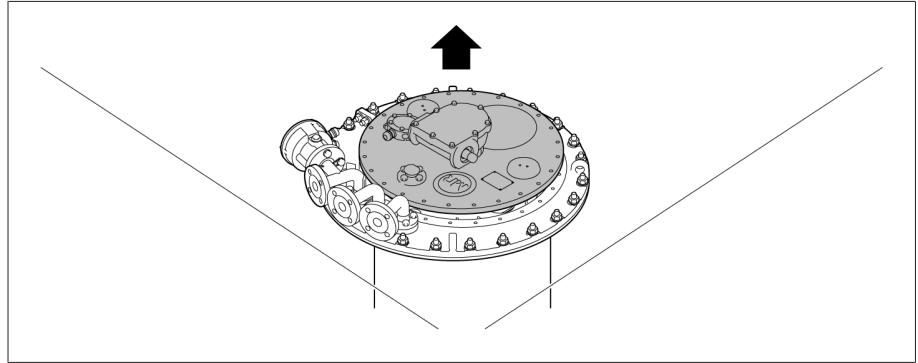

Figure 108: On-load tap-changer head cover

5.3.5.2.3 Opening kerosene drain plug

- > **NOTICE!** Never remove the kerosene drain plug completely. Only unscrew the kerosene drain plug between the oil compartment base and selector gear clockwise until it starts to become hard to open.

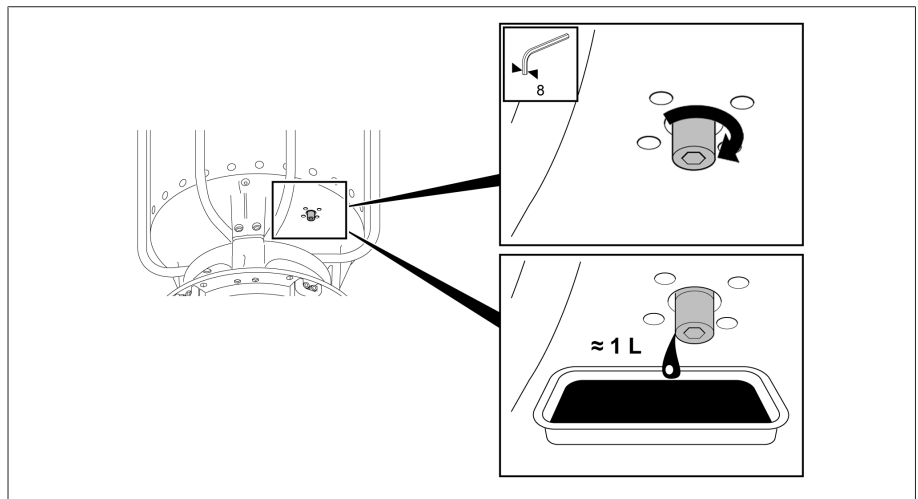

Figure 109: Kerosene drain plug

5.3.5.2.4 Drying the on-load tap-changer

NOTICE

Damage to the on-load tap-changer head cover and on-load tap-changer accessories.

Both the on-load tap-changer head cover and the on-load tap-changer accessories will become damaged if they are dried.

- > Never dry the on-load tap-changer head cover or the following accessories: motor-drive unit, drive shaft, protective relay, pressure monitoring device, pressure relief device, bevel gear, sensors such as temperature and humidity sensors or pressure sensors, oil filter unit.

1. Supply kerosene vapor at a temperature of around 90°C. Keep this temperature constant for 3 to 4 hours.
2. Increase the kerosene vapor temperature by approx. 10°C/hour to the desired final temperature of max. 125°C at the on-load tap-changer.
3. Vacuum-dry on-load tap-changer at between 105°C and maximum 125°C for at least 50 hours.
4. Residual pressure of no more than 10⁻³ bar.

5.3.5.2.5 Closing kerosene drain plug

- > **NOTICE!** An open kerosene drain plug leads to insulating fluid escaping from the oil compartment and therefore to damage to the on-load tap-changer. Close kerosene drain plug (tightening torque 20 Nm).

5.3.5.2.6 Securing on-load tap-changer head cover

NOTICE

Damage to the on-load tap-changer!

A missing or damaged o-ring as well as unclean sealing surfaces lead to insulating fluid escaping and therefore to damage to the on-load tap-changer.

- Ensure that the o-ring is positioned untwisted in the on-load tap-changer head cover.
- Ensure that the o-ring does not become damaged when mounting the cover.
- Ensure that the sealing surfaces on the on-load tap-changer head cover and on-load tap-changer head are clean.

1. Check that the feather key is securely positioned in the adapter shaft. Where necessary, use Vaseline to secure the feather key against falling out.

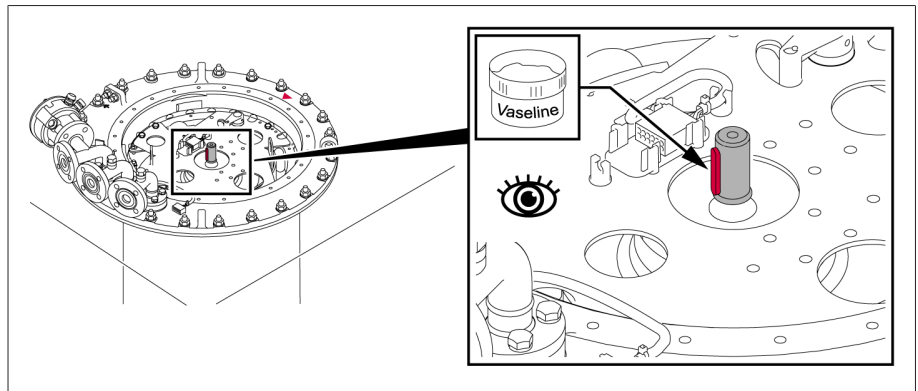

Figure 110: Feather key

2. Position the on-load tap-changer head cover on the on-load tap-changer head in such a way that the red triangular markings on the on-load tap-changer head and the on-load tap-changer head cover are aligned.

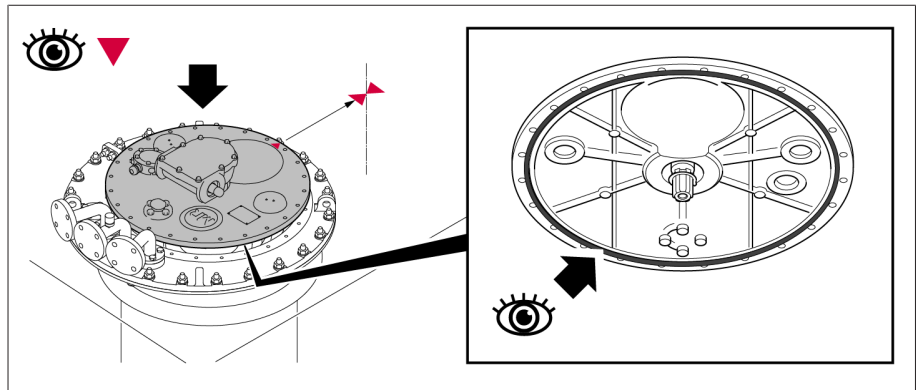

Figure 111: Triangular markings and o-ring

3. Screw the on-load tap-changer head cover onto the on-load tap-changer head.

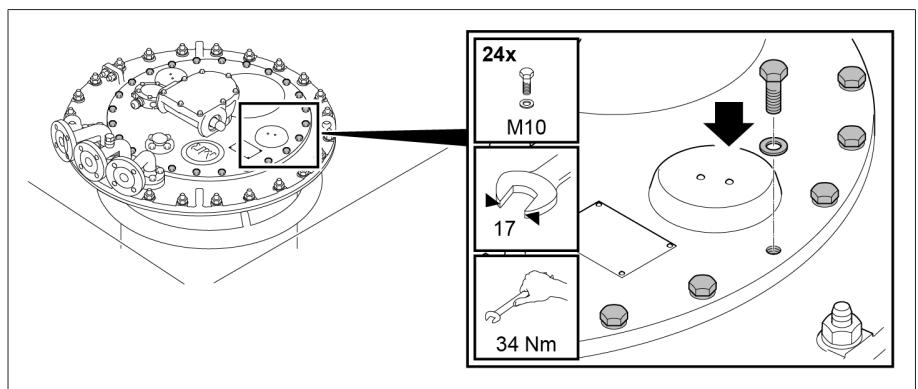

Figure 112: On-load tap-changer head cover

5.3.6 Lifting top part of on-load tap-changer head off supporting flange (bottom part)

5.3.6.1 Removing on-load tap-changer head cover

▲ WARNING



Danger of explosion!

Explosive gases under the on-load tap-changer head cover can deflagrate or explode and result in severe injury or death.

- > Ensure that there are no ignition sources such as open flames, hot surfaces or sparks (e.g. caused by the build-up of static charge) in the immediate surroundings and that none occur.
- > De-energize all auxiliary circuits (for example tap-change supervisory device, pressure relief device, pressure monitoring device) before removing the on-load tap-changer head cover.
- > Do not operate any electrical devices during the work (e.g. risk of sparks from impact wrench).

NOTICE

Damage to the on-load tap-changer!

Small parts in the oil compartment may block the diverter switch insert, thereby damaging the on-load tap-changer.

- > Ensure that parts do not fall into the oil compartment.
- > Check that all small parts are accounted for.

1. Ensure that the inspection window is sealed off with the cover.
2. Remove temporary fastening and spacers and slowly lower the on-load tap-changer.

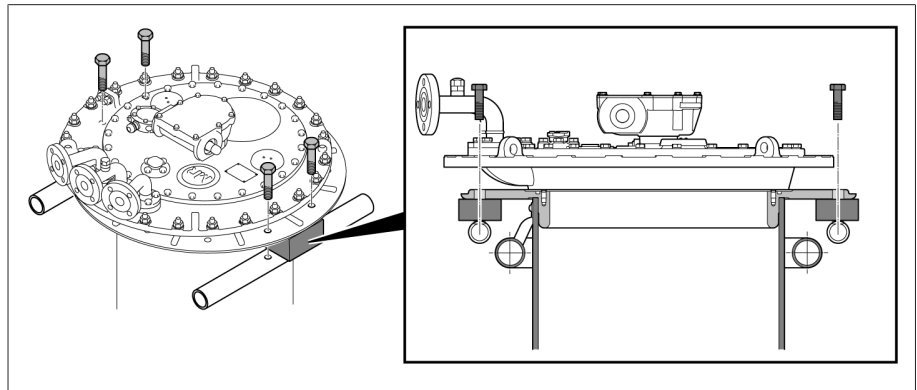

Figure 113: Temporary fasteners and spacers

3. Remove the screws and washers from the on-load tap-changer head cover.

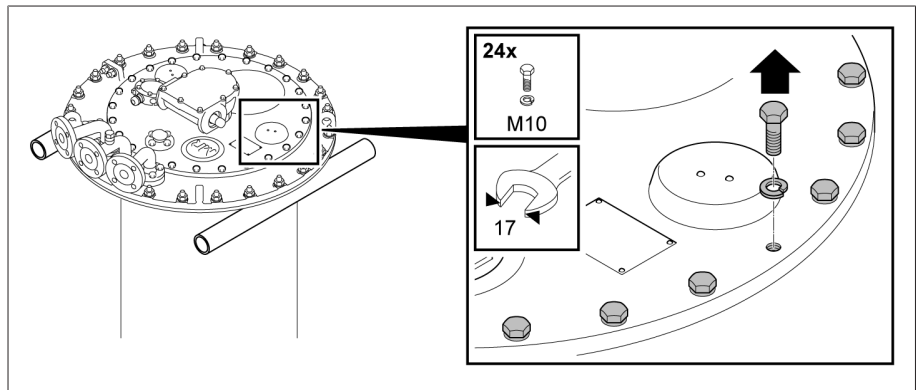

Figure 114: On-load tap-changer head cover

4. Remove on-load tap-changer head cover.

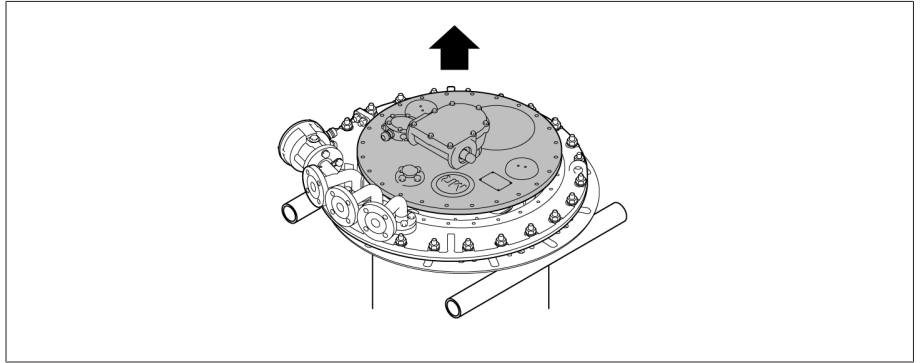

Figure 115: On-load tap-changer head cover

5.3.6.2 Removing tap position indicator disk without multiple coarse change-over selector

> Pull spring clip off shaft end and remove tap position indicator disk.

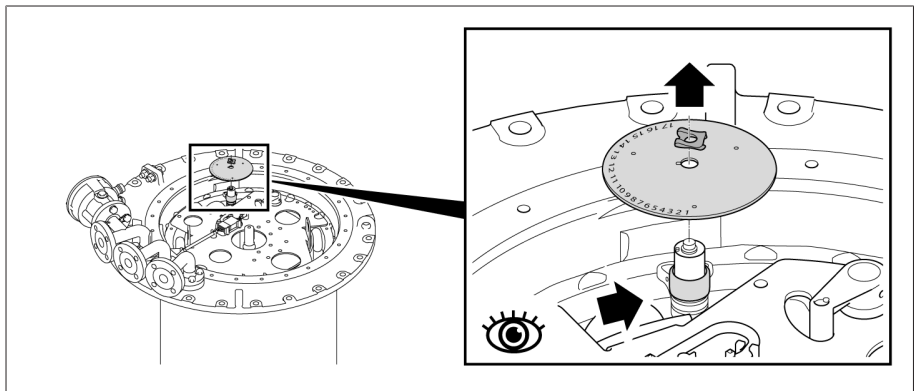

Figure 116: Tap position indicator disk

5.3.6.3 Removing tap position indicator disk with multiple coarse change-over selector with more than 35 operating positions

1. Ensure that the red marks on the panel, tap position indicator disk and cover disk produce a continuous red line.
2. Remove countersunk head screw.

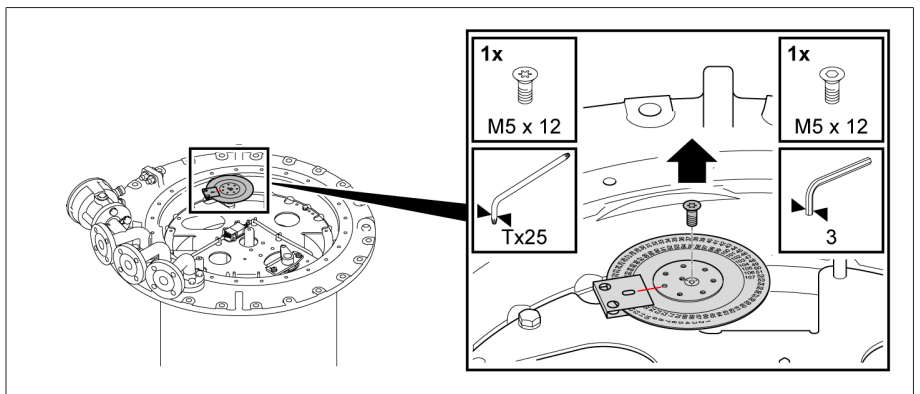

Figure 117: Countersunk head screw

3. Lever cover disk off underlying disk with flat screwdriver and pull out position-indication disk from between panel and bracket.

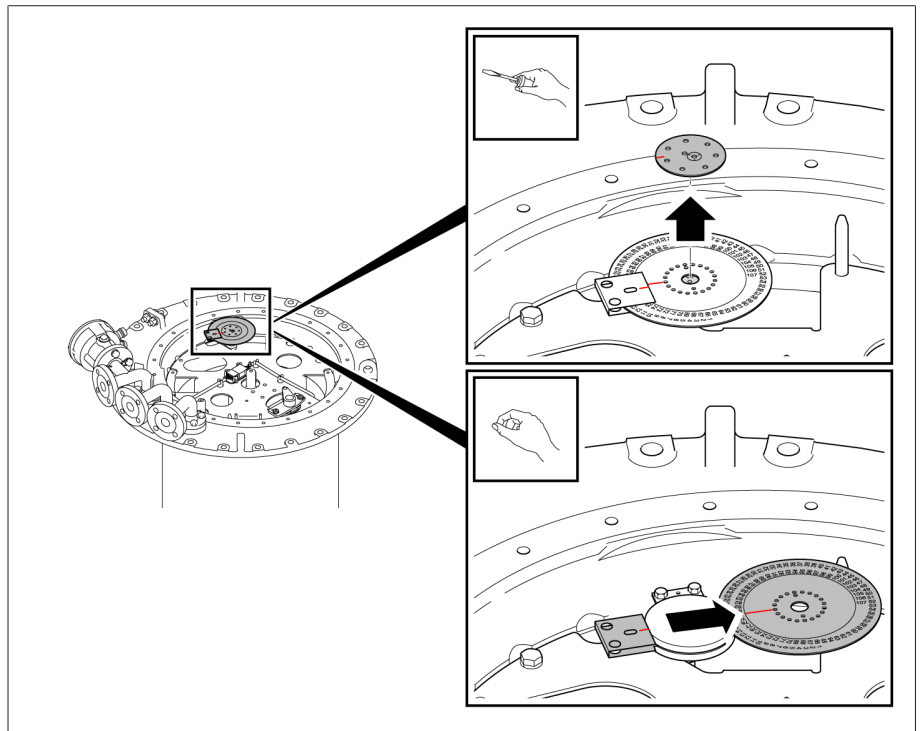

Figure 118: Cover disk and position-indication disk

4. Remove hexagon screws and associated lock tab.

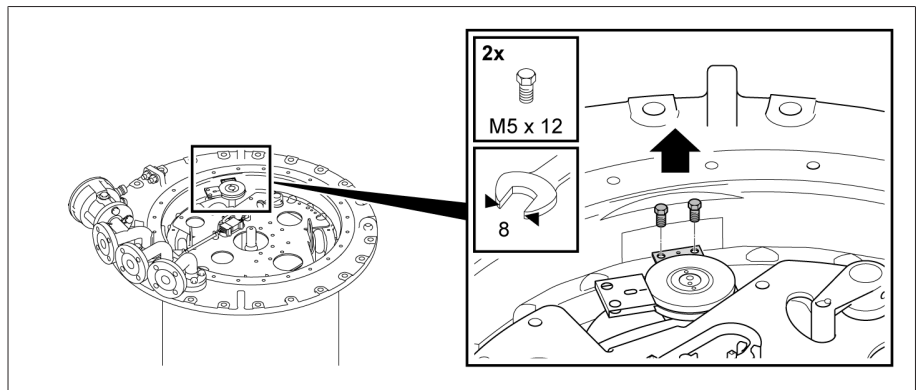

Figure 119: Lock tab

5. Pull panel and bracket up and off indicator drive shaft.

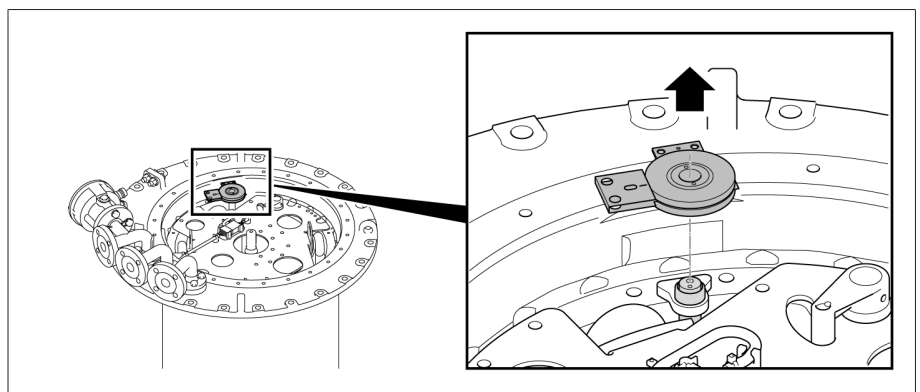

Figure 120: Panel

5.3.6.4 Disconnecting the plug connector of the tap-change supervisory control

⚠ DANGER



Electric shock!

If supply voltage is applied to the tap-change supervisory device, this can result in electric shock.

- > Disconnect the tap-change supervisory device from the supply voltage and secure it to prevent it from being switched back on again.

NOTICE

Damage to the tap-change supervisory device!

Disconnecting the tap-change supervisory device without due care may damage it, thereby resulting in damage to the on-load tap-changer.

- > Disconnect the tap-change supervisory device with care in order not to damage or rip out the connecting leads.

1. Lift plug connector and leads out of bracket and retaining clamps.

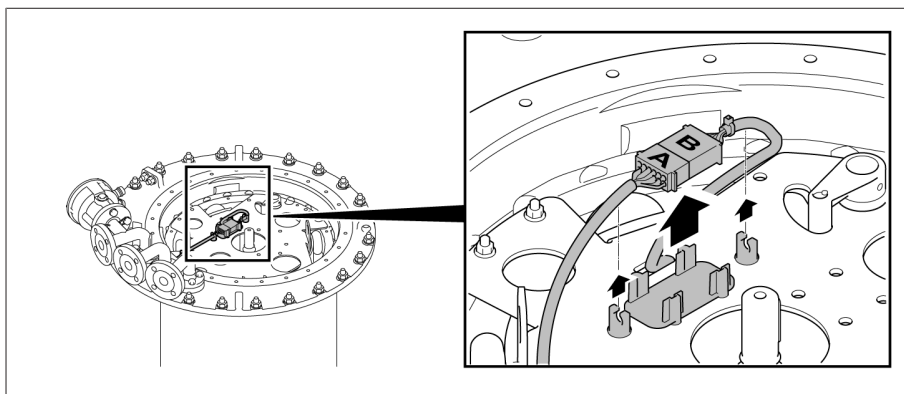

Figure 121: Lifting out plug connector

2. Disconnect the plug connector.

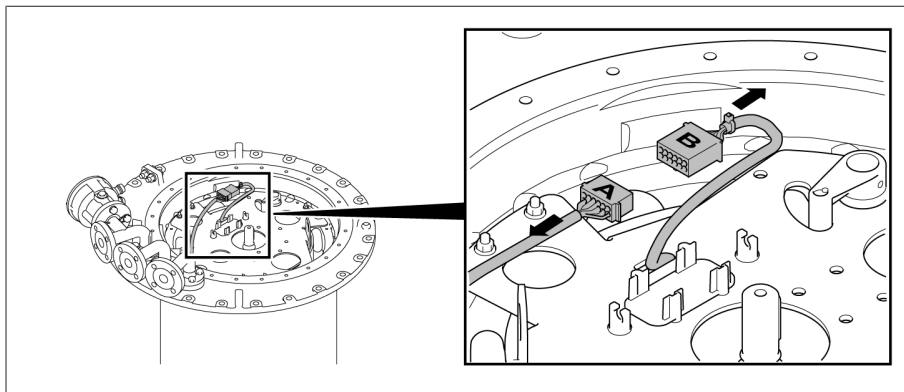

Figure 122: Disconnecting plug connector

3. Put part B of plug connector back in bracket.

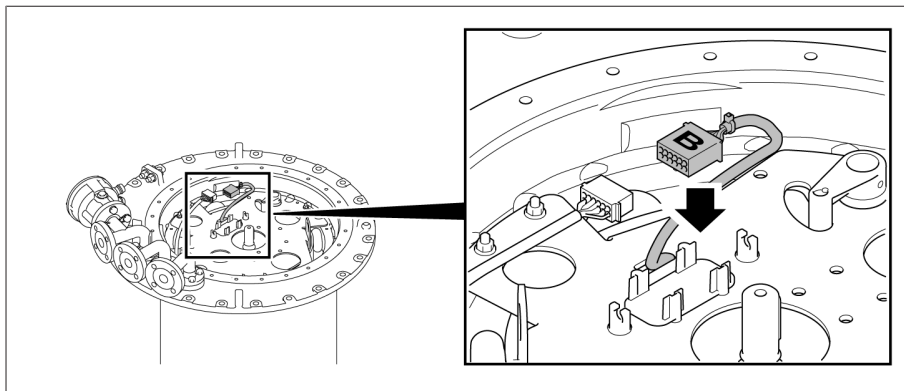

Figure 123: Placing part B of plug connector in bracket

- Swivel part A of plug connector out of on-load tap-changer head in direction indicated by arrow until it is between the pipe connections and the cable cannot be damaged when pulling out the diverter switch insert.

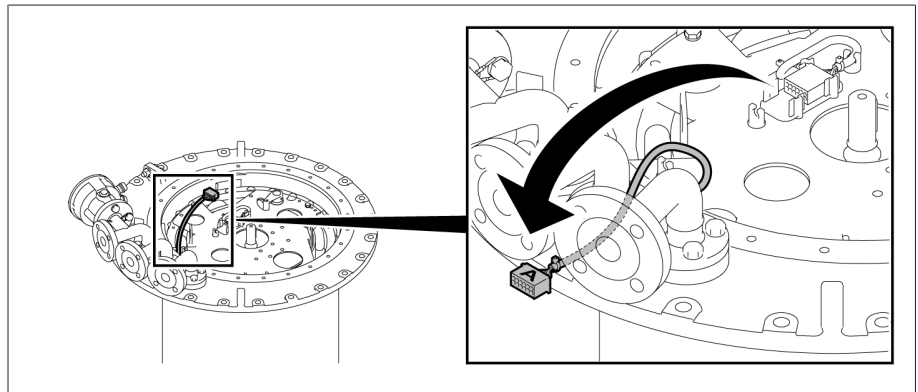

Figure 124: Swiveling out part A of plug connector

5.3.6.5 Lifting out diverter switch insert

- Remove attachment and locking elements on carrier plate of diverter switch insert.

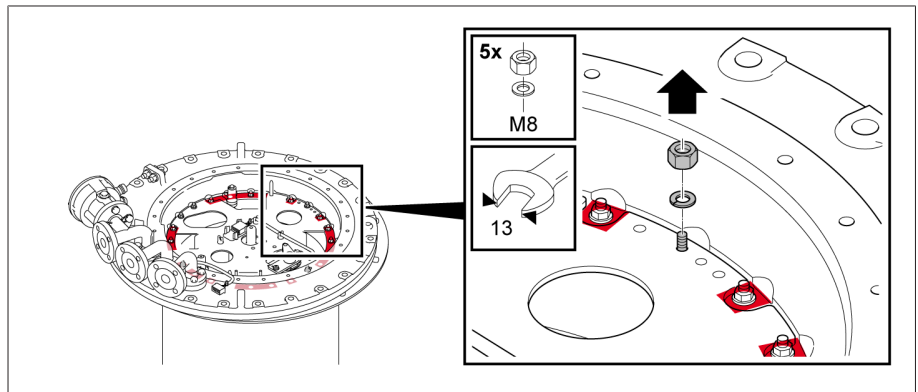

Figure 125: Carrier plate of diverter switch insert

- Insert lifting gear in the brackets on the diverter switch insert carrier plate and position vertically above the diverter switch insert.

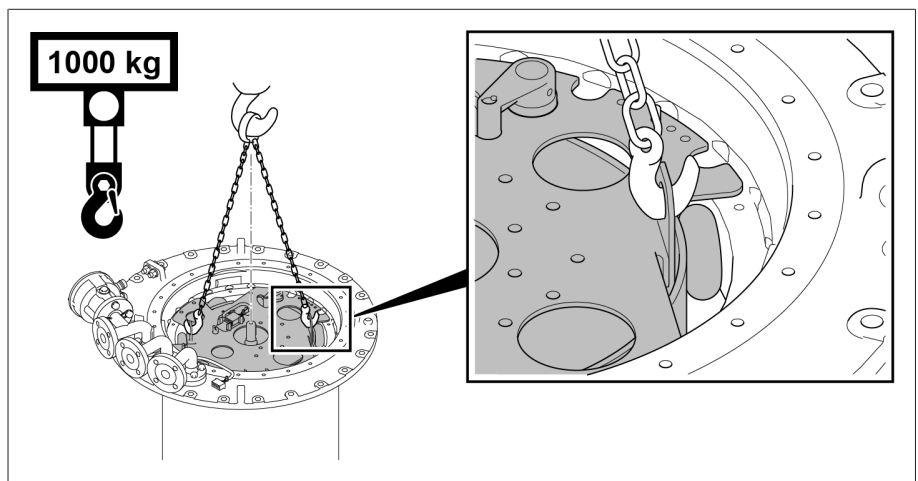

Figure 126: Brackets on carrier plate

3. Lift out diverter switch insert slowly and vertically.

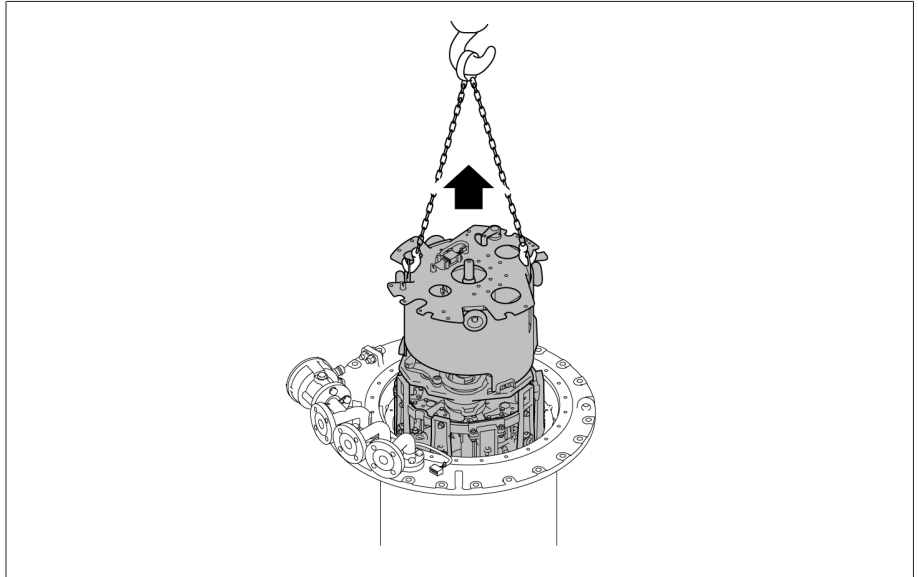

Figure 127: Lifting out diverter switch insert

4. **⚠ CAUTION!** An unstably positioned diverter switch insert may tip, resulting in injuries and property damage. Place the diverter switch insert on a level surface and secure it against tipping.
5. Note down whether the diverter switch insert is in the final end position on side A or side B. If the diverter switch insert is in the final end position on side A, the vacuum interrupter on side A is closed, and vice versa. In the example in the appendix, the diverter switch insert is in the final end position on side B.

5.3.6.6 Removing the oil suction pipe

- › Pull the connecting piece of the oil suction pipe in the on-load tap-changer head inwards and out. Pay attention to the O-ring.

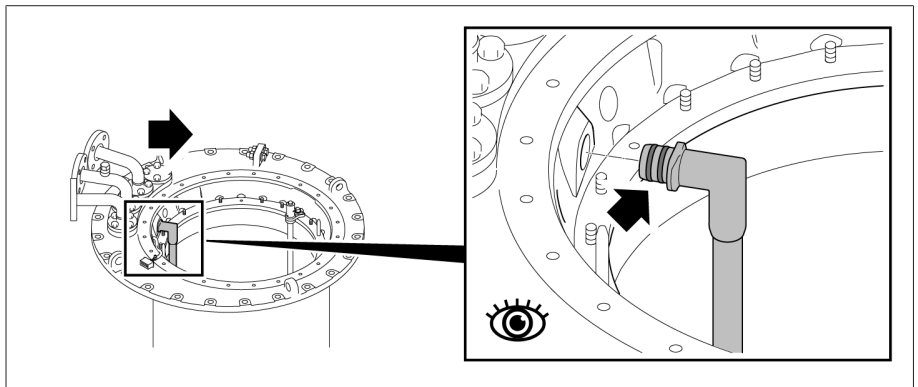

Figure 128: Oil suction pipe

5.3.6.7 Lifting top part of on-load tap-changer head off supporting flange

1. Remove nuts and locking elements between top part of on-load tap-changer head and supporting flange.

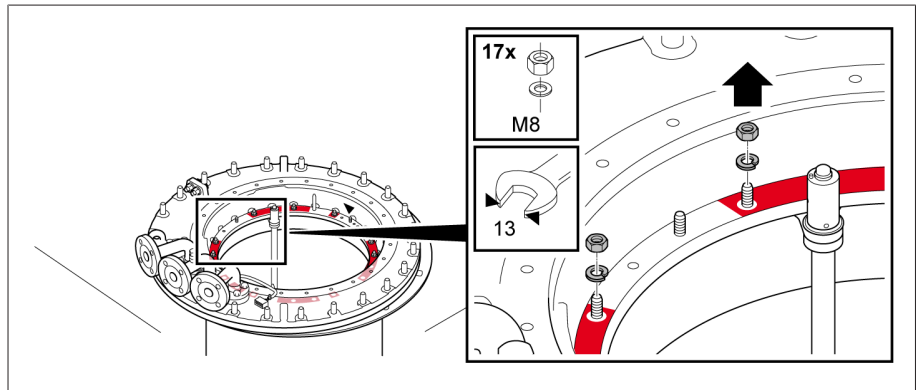

Figure 129: Top part of on-load tap-changer head with nuts

2. Lift top part of on-load tap-changer head off supporting flange.

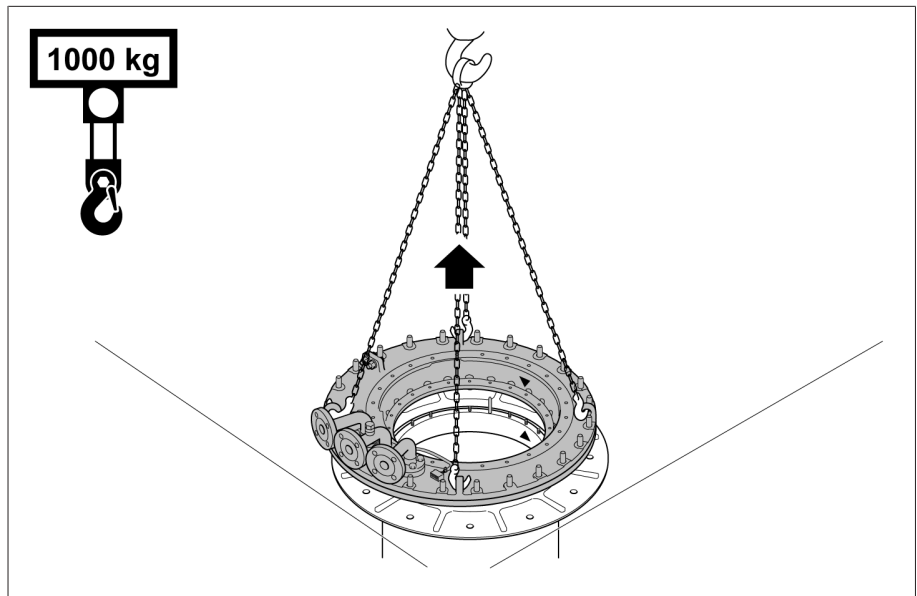

Figure 130: Top part of on-load tap-changer head

5.3.7 Attaching the bell-type tank and connecting the on-load tap-changer to the top part of the on-load tap-changer head

5.3.7.1 Attaching bell-type tank

1. Clean sealing surface of supporting flange, place o-ring on supporting flange.

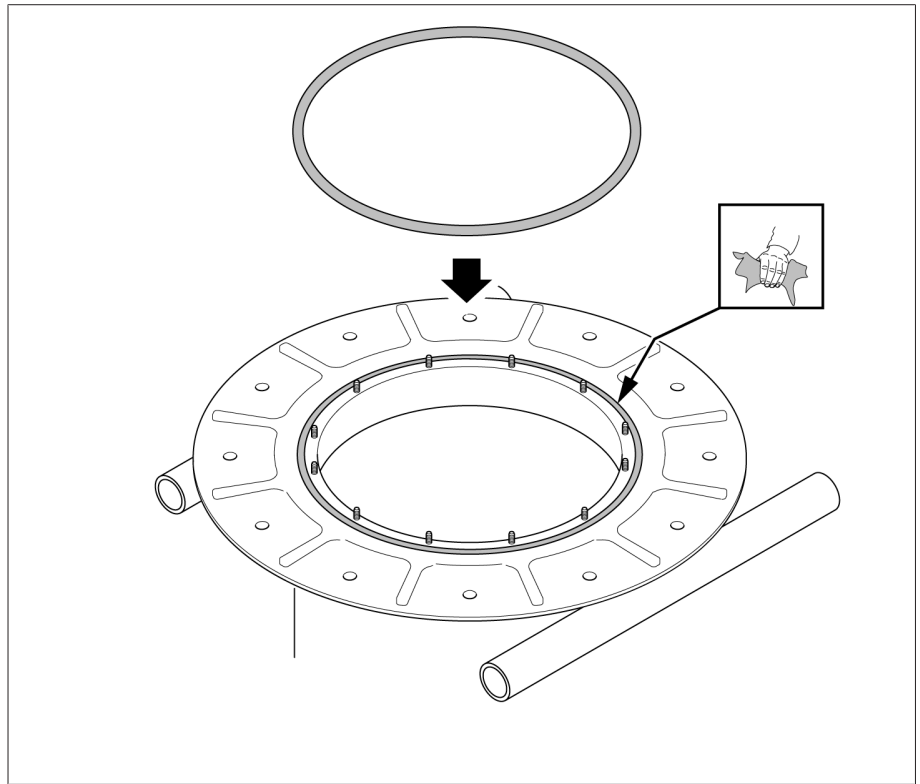

Figure 131: Supporting flange with o-ring

2. Lift the bell-type tank over the active part of the transformer.

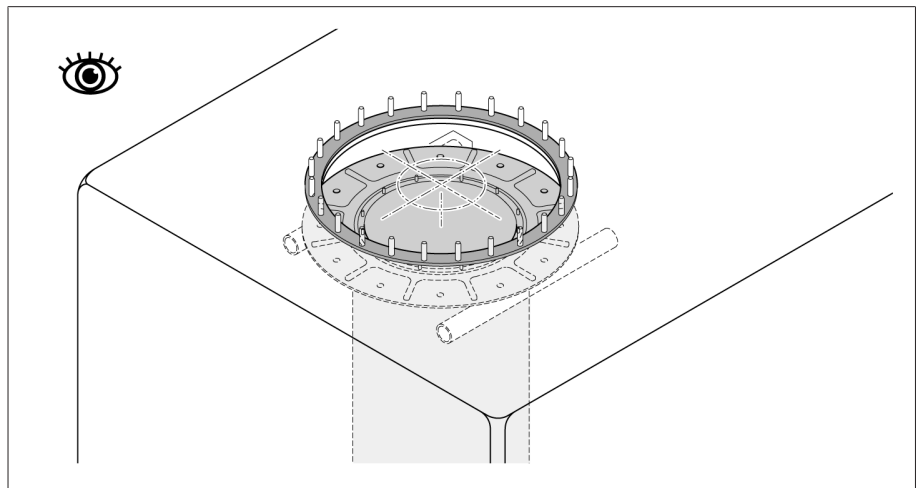

Figure 132: Bell-type tank

5.3.7.2 Positioning top part of on-load tap-changer head on bell-type tank

1. **NOTICE!** Unsuitable gaskets may lead to oil escaping and therefore to damage to the on-load tap-changer. Place a gasket **1** suitable for the insulating fluid used on the mounting flange **2**. Clean the sealing surfaces on the mounting flange and on-load tap-changer head.

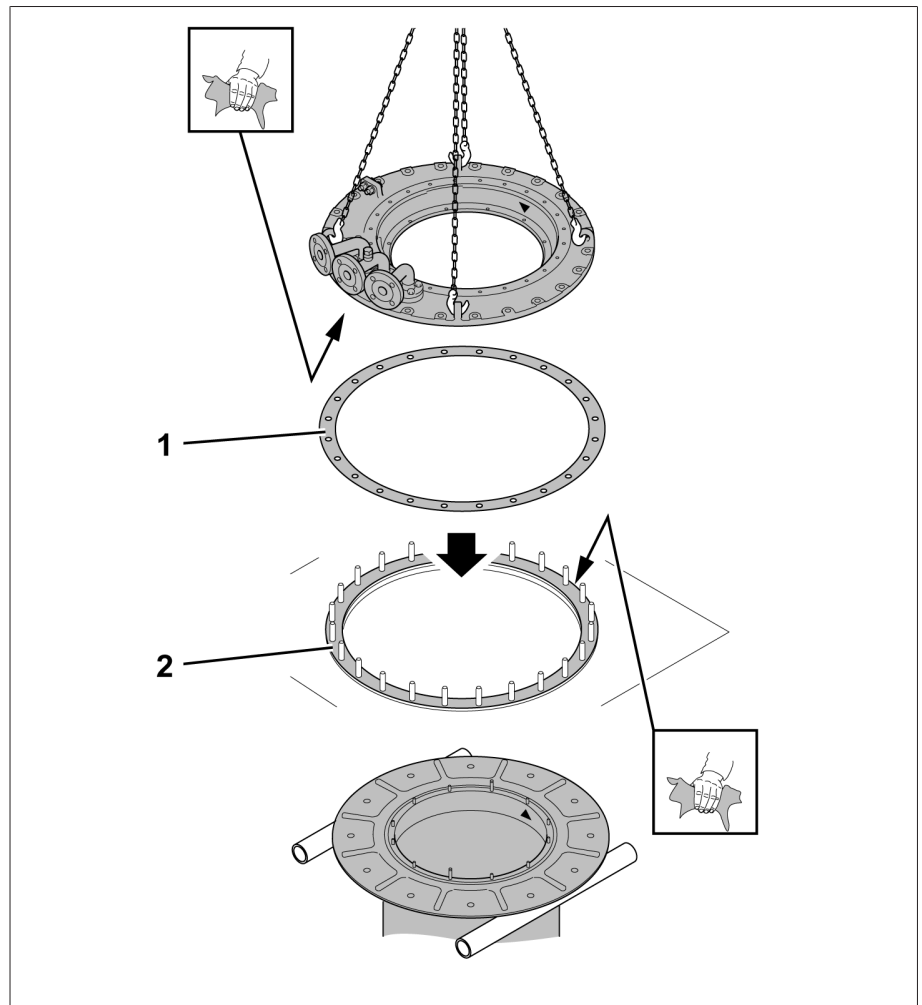

Figure 133: Mounting flange with gasket

- Lower and position the top part of the on-load tap-changer head on mounting flange so that the triangular markings, pins and mounting holes on the top part and bottom part of the on-load tap-changer head are aligned.

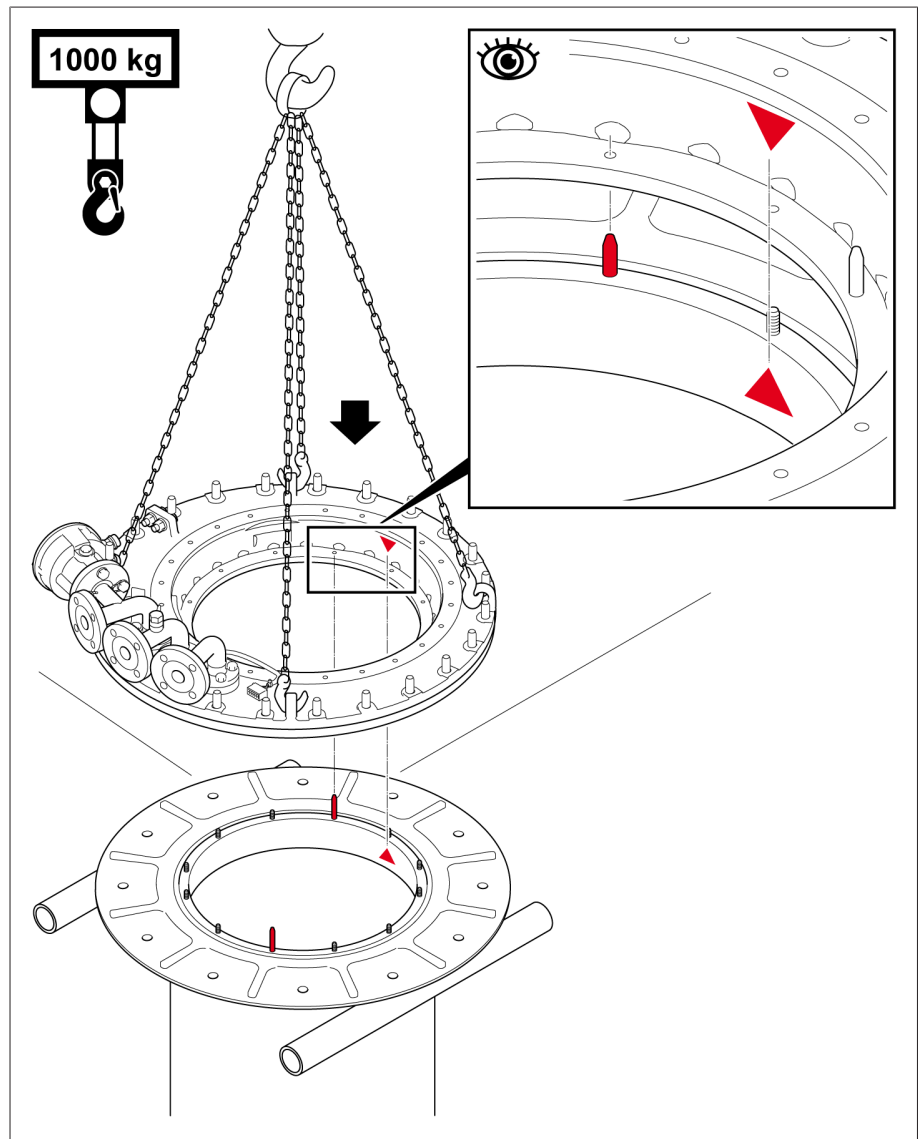

Figure 134: Markings and fitted bolt

5.3.7.3 Connecting on-load tap-changer to top part of on-load tap-changer head

NOTICE

Incorrectly lifting the on-load tap-changer will damage it!

If the connection screws of the supporting flange are used to lift the on-load tap-changer, the screws may be damaged, which makes it impossible to properly screw the on-load tap-changer and the on-load tap-changer head together!

- > Always lift the on-load tap-changer with the specified lifting traverse, and never with the connection screws of the supporting flange.

1. Insert lifting traverse in on-load tap-changer head.

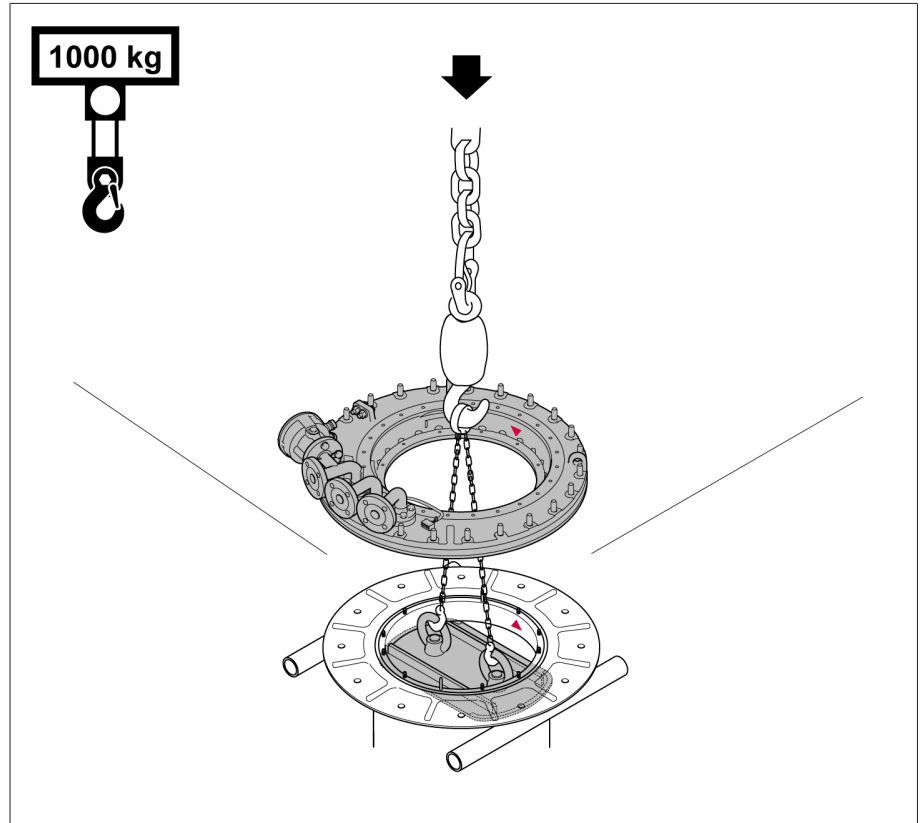

Figure 135: Lifting traverse

2. **NOTICE!** Inaccurate alignment of on-load tap-changer head to supporting flange will damage the on-load tap-changer when it is lifted. Lift on-load tap-changer with lifting traverse and ensure that the triangular markings are aligned and that all supporting flange stud bolts go easily through the mounting holes of the on-load tap-changer head.

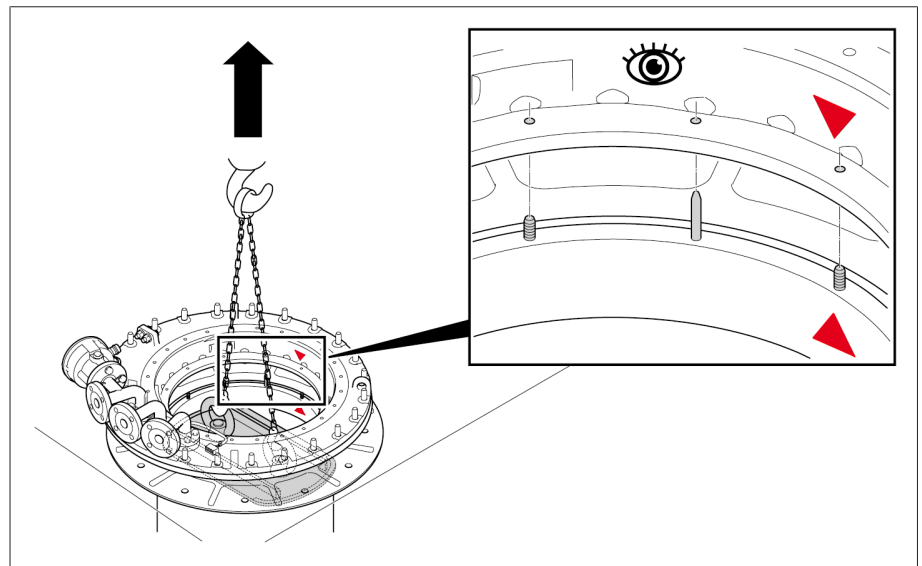

Figure 136: Lifting on-load tap-changer

3. Screw the top part and bottom part of the on-load tap-changer head together in the area marked in red.

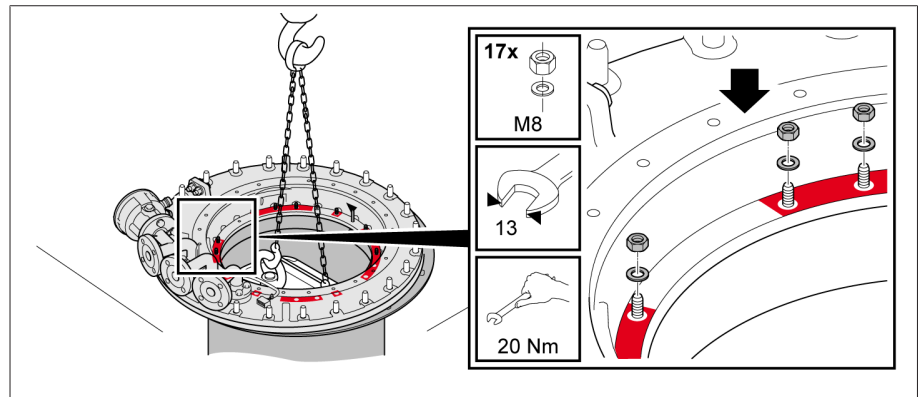

Figure 137: Screwing the on-load tap-changer head onto the supporting flange

4. Remove lifting traverse.

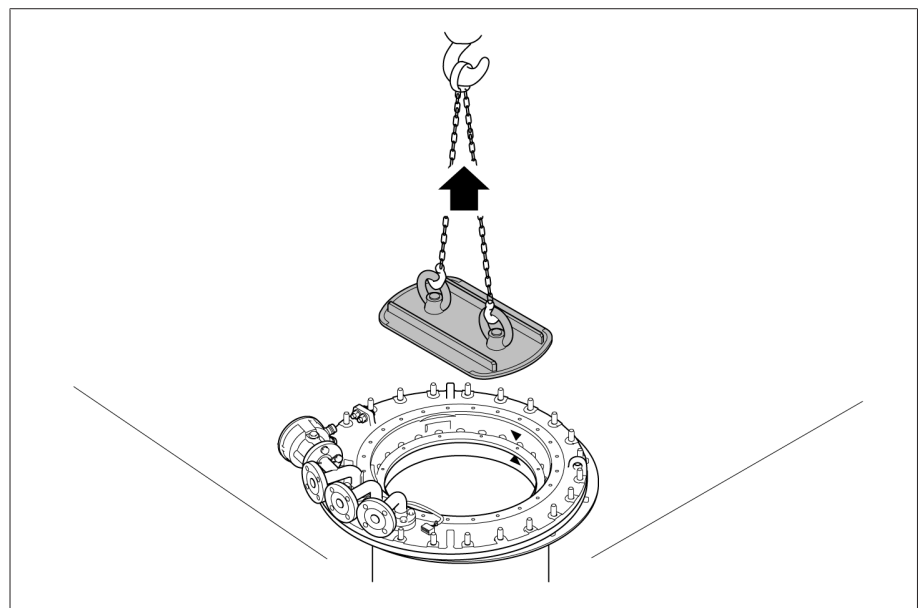

Figure 138: Removing lifting traverse

5. Screw the on-load tap-changer head to the mounting flange.

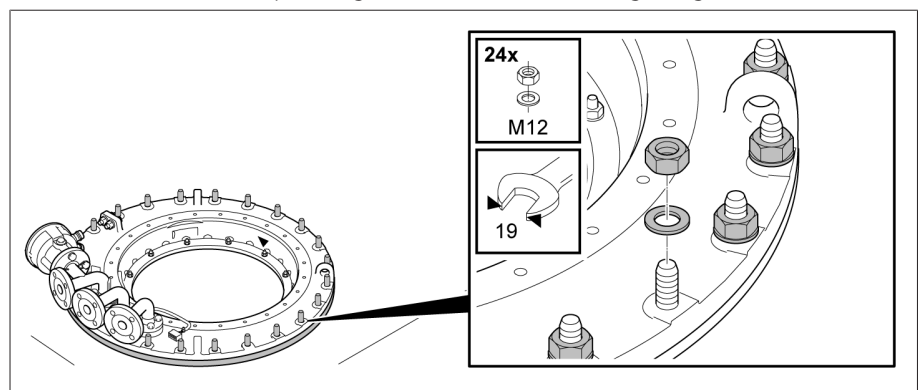

Figure 139: Screwing the on-load tap-changer head to the mounting flange

5.3.7.4 Inserting oil suction pipe

1. Lightly grease the O-rings of the oil suction pipe.
2. Insert the oil suction pipe into the on-load tap-changer head. Make sure the O-rings are correctly fitted.

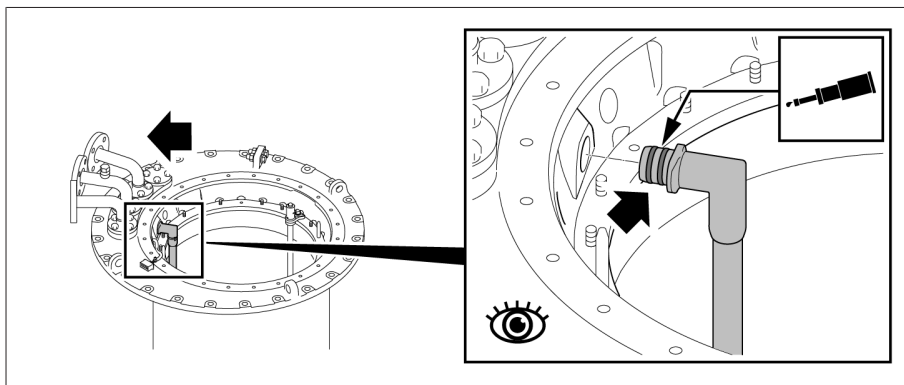

Figure 140: Oil suction pipe

5.3.7.5 Inserting diverter switch insert

1. To fit diverter switch insert, ensure that selector coupling and indicator gear are in the adjustment position.

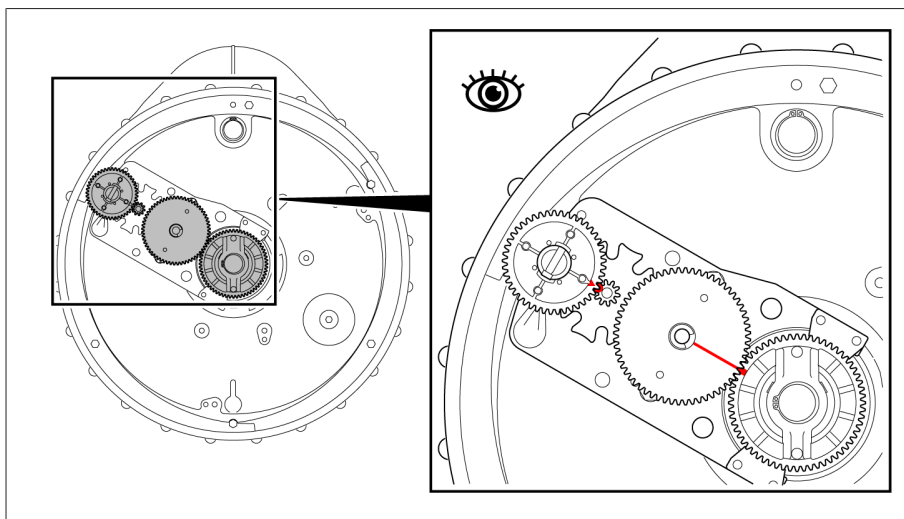

Figure 141: Adjustment position

2. Insert lifting gear in the brackets provided on the diverter switch insert carrier plate and position vertically above the diverter switch insert.

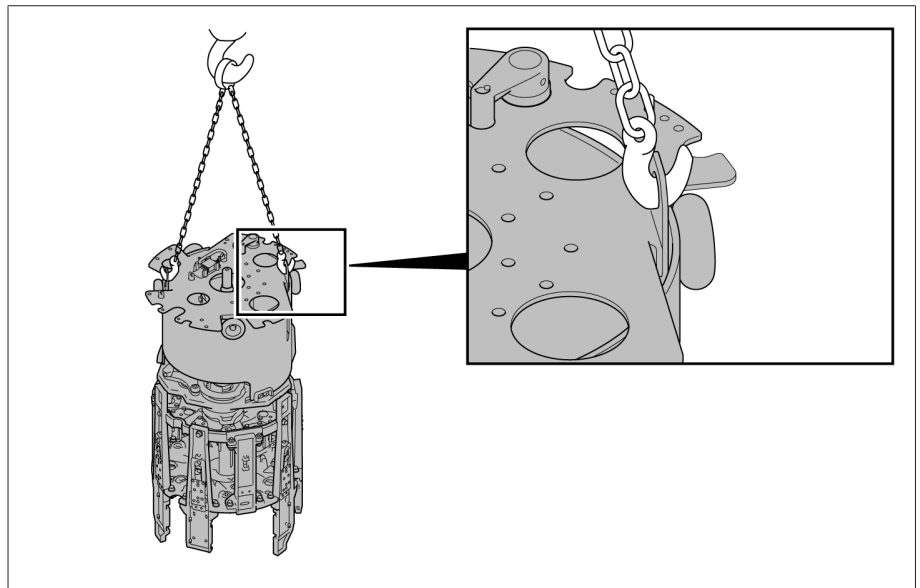

Figure 142: Brackets on carrier plate

3. Ensure that diverter switch insert is in the final end position on the same side as when it was removed (side A or side B). The vacuum interrupter is closed on the side that is in the final end position. In the example in the appendix, side B is in the final end position, see appendix.
4. By turning the coupling tube, align it in such a manner that the red triangles on the coupling tube and carrier plate match up.

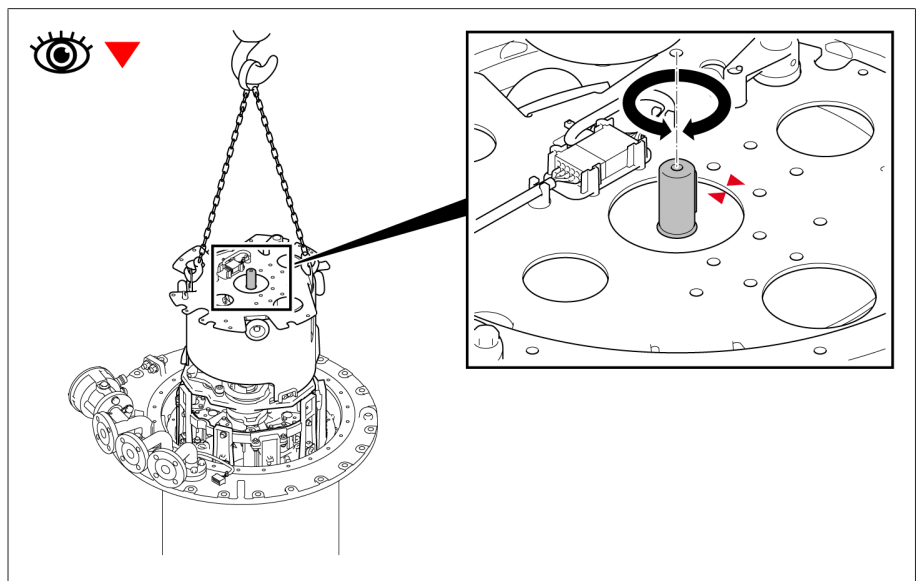

Figure 143: Coupling tube

5. **NOTICE!** Mixing up the diverter switch inserts will lead to damage to the on-load tap-changer. Ensure the same number of triangles on the top of the energy accumulator and on-load tap-changer head.

6. Align diverter switch insert such that the red triangles at the top of the energy accumulator and on the on-load tap-changer head are opposite one another. Slowly lower diverter switch insert.

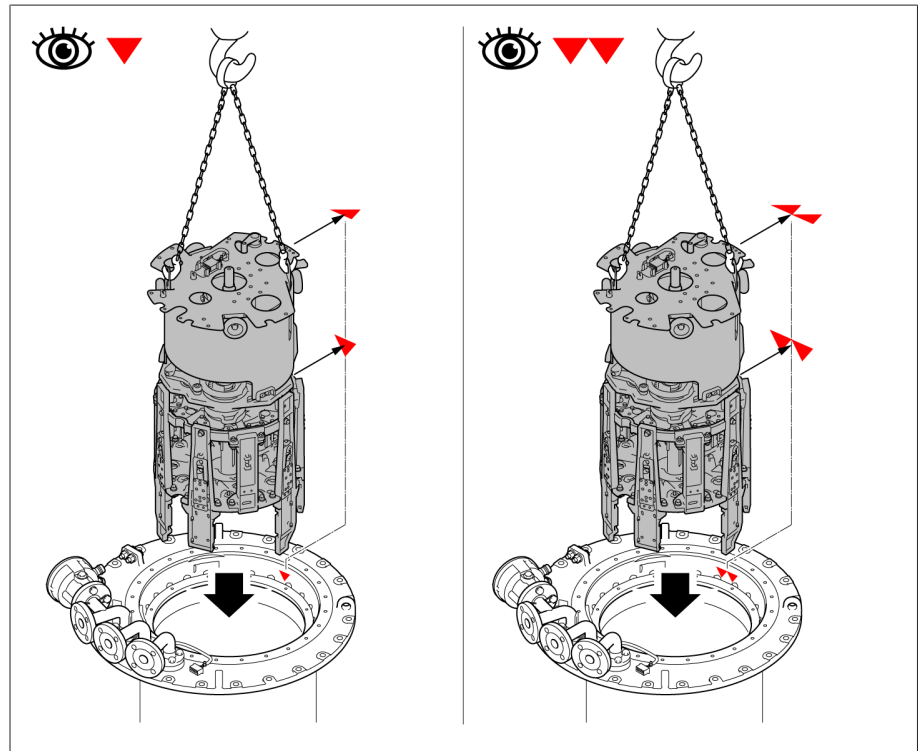

Figure 144: Aligning diverter switch insert

7. Slowly lower diverter switch insert.
8. Ensure correct position of carrier plate in on-load tap-changer head. Area marked red must remain free.
9. Secure carrier plate of diverter switch insert.

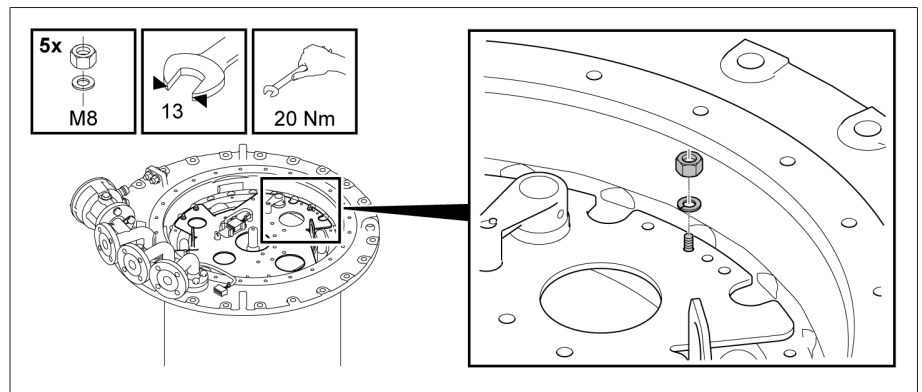

Figure 145: Carrier plate of diverter switch insert

5.3.7.6 Connecting plug connector of the tap-change supervisory device

1. Lift part B of plug connector out of bracket.

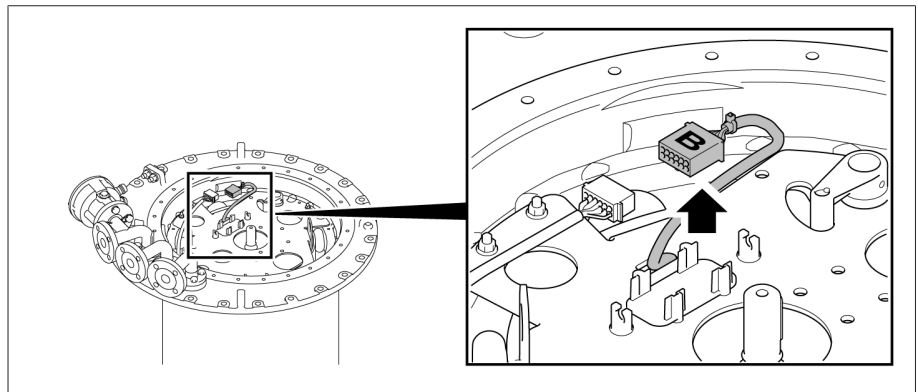

Figure 146: Part B of plug connector

2. Connecting plug connector

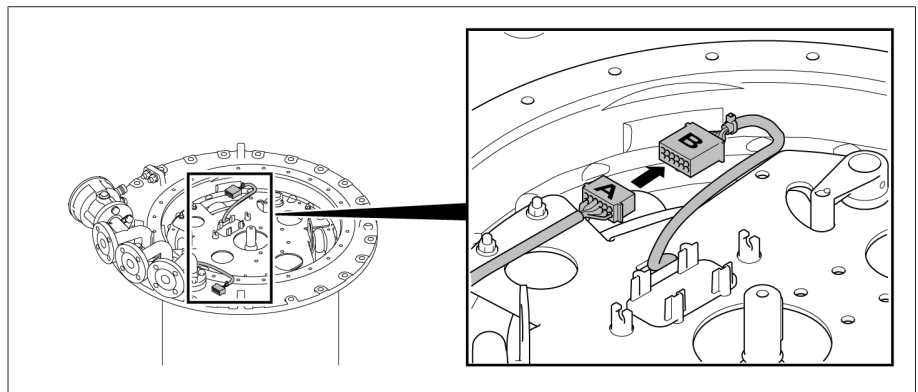

Figure 147: Connecting plug connector

3. Place plug connector in bracket, secure leads on both sides of plug connector in retaining clamps.

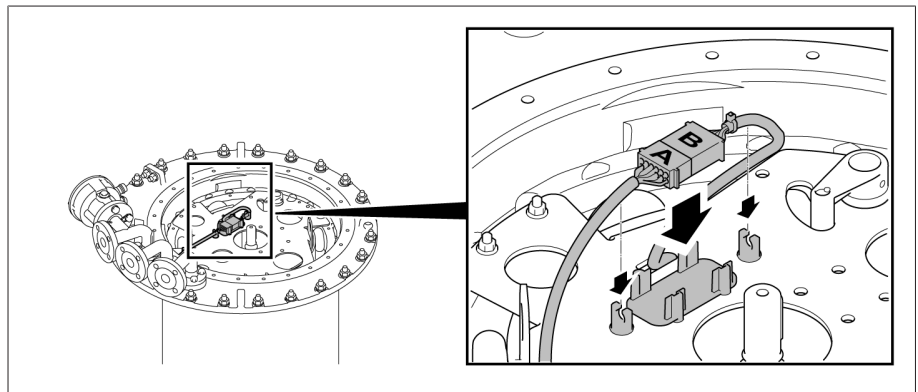

Figure 148: Placing plug connector in bracket

5.3.7.7 Inserting the tap position indicator without multiple coarse change-over selector

- Due to the coupling pin, the tap position indicator disc can only be installed when in the correct position.

- > Place tap position indicator disk on indicator drive shaft, slide spring clip on to shaft end.

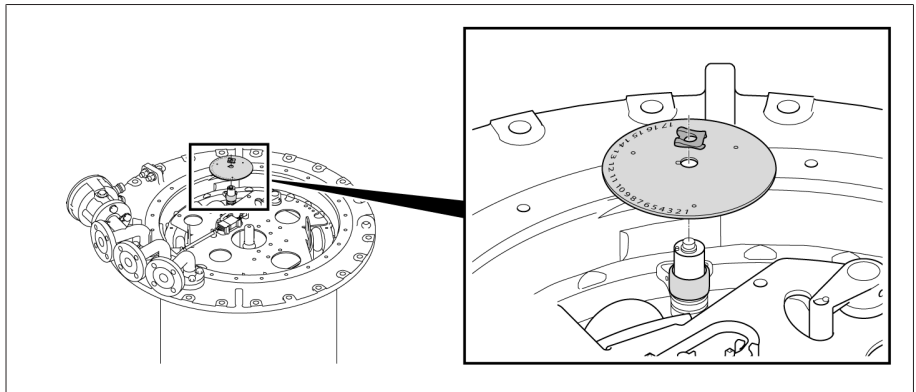

Figure 149: Tap position indicator disk

5.3.7.8 Inserting tap position indicator with multiple coarse change-over selector with more than 35 operating positions

1. Place panel with bracket on indicator drive shaft and fasten with hexagon screws and associated lock tab.

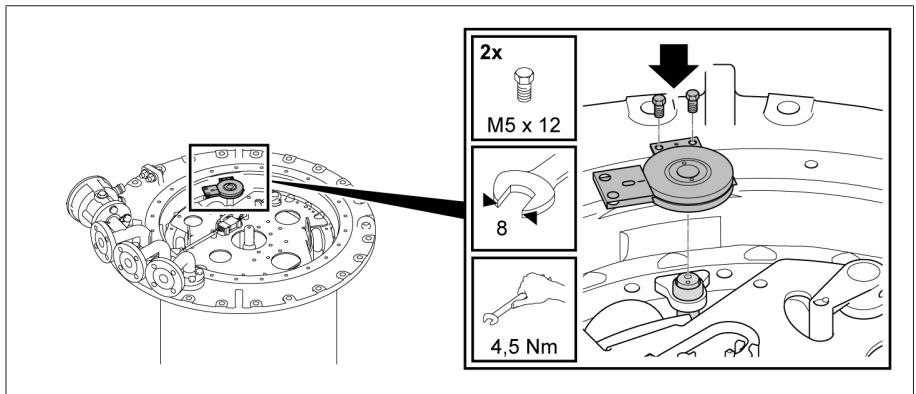

Figure 150: Fitting panel

2. Insert position-indication disk horizontally between panel and bracket and fit cover disk. Align tap position indicator disc and cover disk to produce a continuous red line.

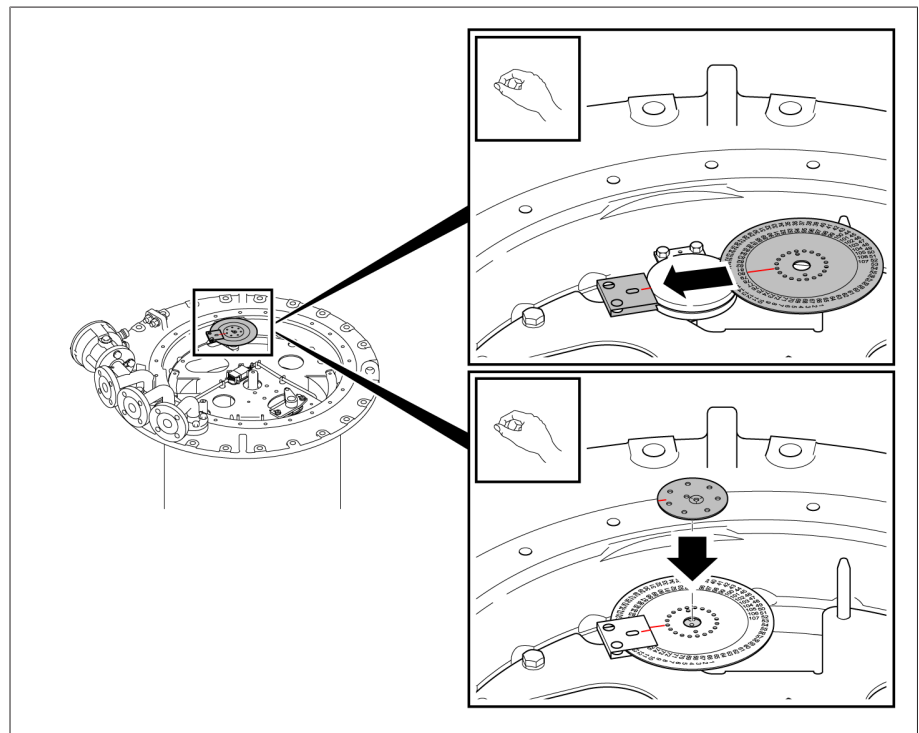

Figure 151: Inserting position-indication disk

3. Secure cover disk with countersunk head screw. The countersunk head screw must be suitable for center-punching.

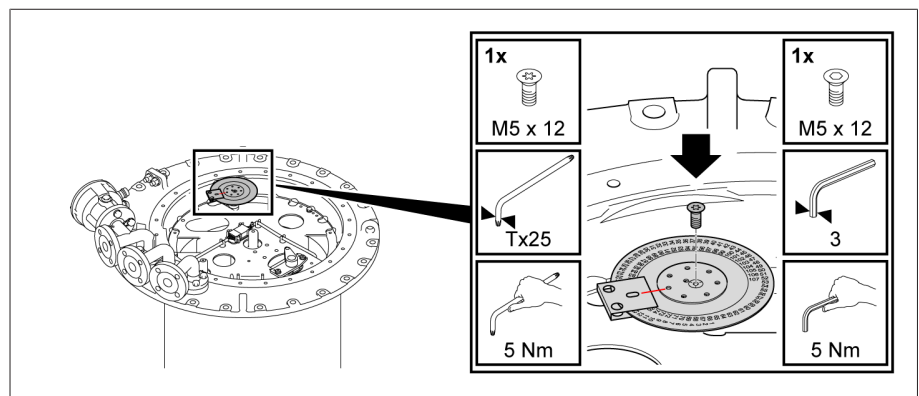

Figure 152: Fastening cover disk

4. Secure countersunk head screw by center-punching.

5.3.7.9 Securing on-load tap-changer head cover

NOTICE

Damage to the on-load tap-changer!

A missing or damaged o-ring as well as unclean sealing surfaces lead to insulating fluid escaping and therefore to damage to the on-load tap-changer.

- > Ensure that the o-ring is positioned untwisted in the on-load tap-changer head cover.
- > Ensure that the o-ring does not become damaged when mounting the cover.
- > Ensure that the sealing surfaces on the on-load tap-changer head cover and on-load tap-changer head are clean.

1. Check that the feather key is securely positioned in the adapter shaft. Where necessary, use Vaseline to secure the feather key against falling out.

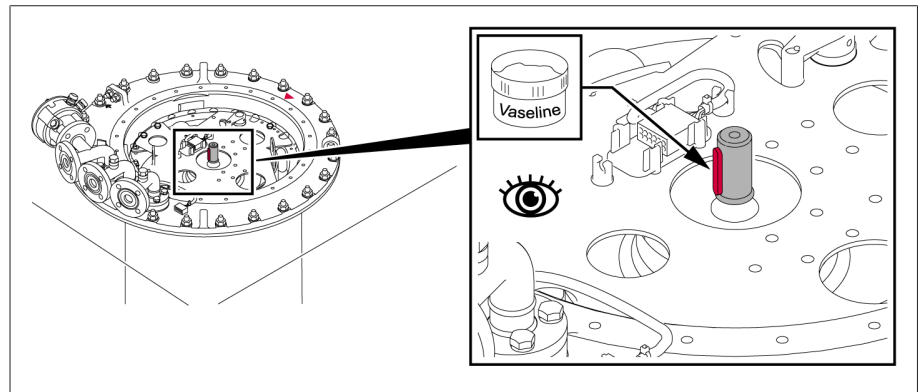

Figure 153: Feather key

2. Position the on-load tap-changer head cover on the on-load tap-changer head in such a way that the red triangular markings on the on-load tap-changer head and the on-load tap-changer head cover are aligned.

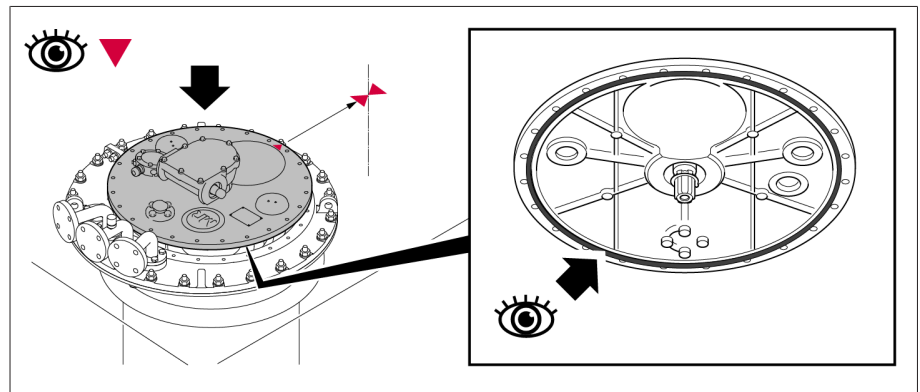

Figure 154: Triangular markings and o-ring

3. Screw the on-load tap-changer head cover onto the on-load tap-changer head.

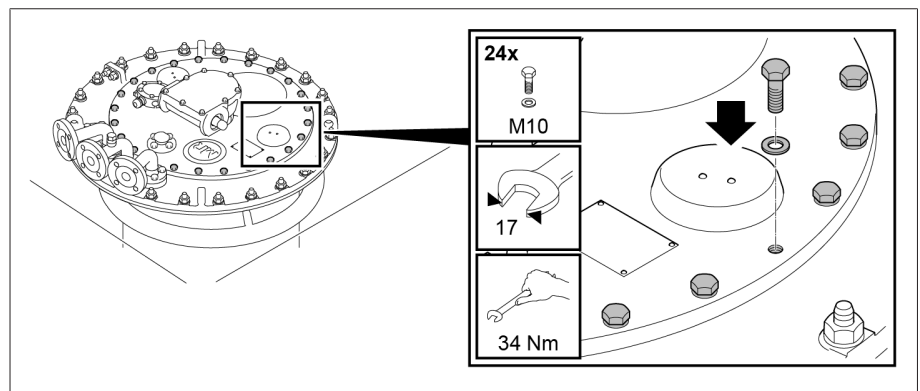

Figure 155: On-load tap-changer head cover

5.3.8 Drying on-load tap-changer in transformer tank

Dry on-load tap-changer in accordance with the following instructions to ensure the dielectric values assured by MR on the on-load tap-changer.

If you want to dry the on-load tap-changer in the transformer tank, fully assemble the transformer first and then undertake drying.

If drying in the transformer tank, the following methods are possible:

- Vacuum-drying
- Vapor-phase drying

As an alternative to drying the on-load tap-changer in the transformer tank, it can also be dried in an autoclave.

5.3.8.1 Vacuum-drying in the transformer tank



The on-load tap-changer head cover remains closed during the entire drying process.

1. Establish a connecting lead between either connections E2 and Q or connections E2 and R on the on-load tap-changer head.
2. Seal off unused pipe connections with a suitable blank cover.

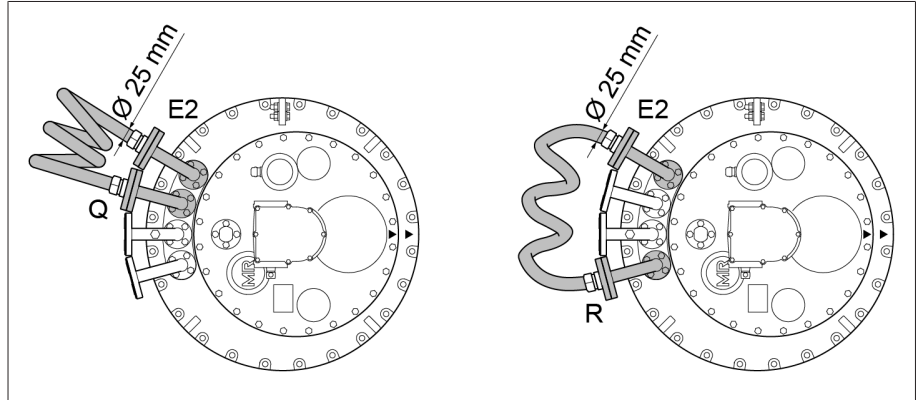

Figure 156: Connecting lead

Vacuum-drying in the transformer tank

1. Heat up the on-load tap-changer in air at atmospheric pressure with a temperature increase of approximately 10 °C/h to a final temperature of maximum 110 °C.
2. Pre-dry the on-load tap-changer in circulating air at a maximum temperature of 110 °C for a period of at least 20 hours.
3. Vacuum-dry on-load tap-changer at between 105 °C and maximum 125 °C for at least 50 hours.
4. Residual pressure of no more than 10⁻³ bar.



If you wish to perform another transformer ratio test after drying, proceed as described in the section "Performing transformer ratio test following drying" [► Section 5.3.10, Page 117].

5.3.8.2 Vapor-phase drying in the transformer tank

If you have opened the kerosene drain plug already (e.g. after the transformer ratio test), you can begin the drying [► Section 5.3.8.2.4, Page 115] right away.

Otherwise, you first have to open the kerosene drain plug before you can begin the drying.

5.3.8.2.1 Removing diverter switch insert

5.3.8.2.1.1 Moving on-load tap-changer to adjustment position

- Move the on-load tap-changer to the adjustment position. The adjustment position is indicated in the on-load tap-changer connection diagram included in delivery.

5.3.8.2.1.2 Removing on-load tap-changer head cover

⚠ WARNING



Danger of explosion!

Explosive gases under the on-load tap-changer head cover can deflagrate or explode and result in severe injury or death.

- > Ensure that there are no ignition sources such as open flames, hot surfaces or sparks (e.g. caused by the build-up of static charge) in the immediate surroundings and that none occur.
- > De-energize all auxiliary circuits (for example tap-change supervisory device, pressure relief device, pressure monitoring device) before removing the on-load tap-changer head cover.
- > Do not operate any electrical devices during the work (e.g. risk of sparks from impact wrench).

NOTICE

Damage to the on-load tap-changer!

Small parts in the oil compartment may block the diverter switch insert, thereby damaging the on-load tap-changer.

- > Ensure that parts do not fall into the oil compartment.
- > Check that all small parts are accounted for.

1. Ensure that the inspection window is sealed off with the cover.
2. Remove the screws and washers from the on-load tap-changer head cover.

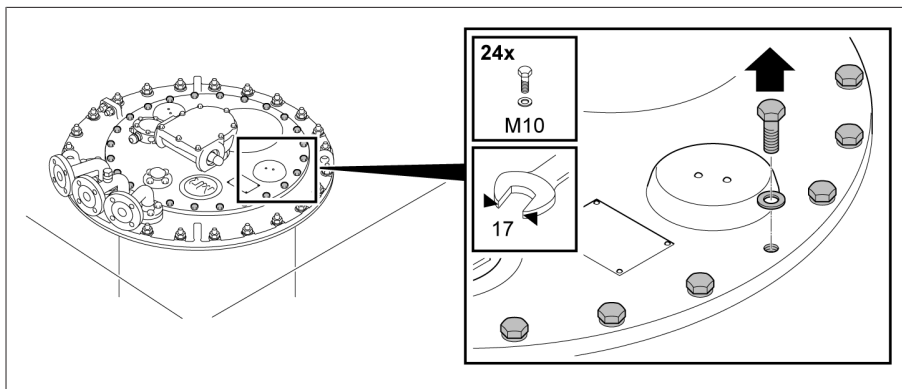

Figure 157: On-load tap-changer head cover

3. Remove on-load tap-changer head cover.

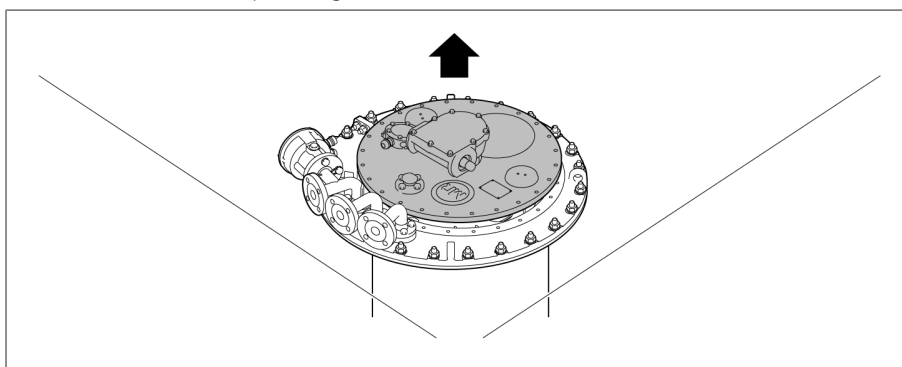

Figure 158: On-load tap-changer head cover

5.3.8.2.1.3 Removing tap position indicator disk without multiple coarse change-over selector

- Pull spring clip off shaft end and remove tap position indicator disk.

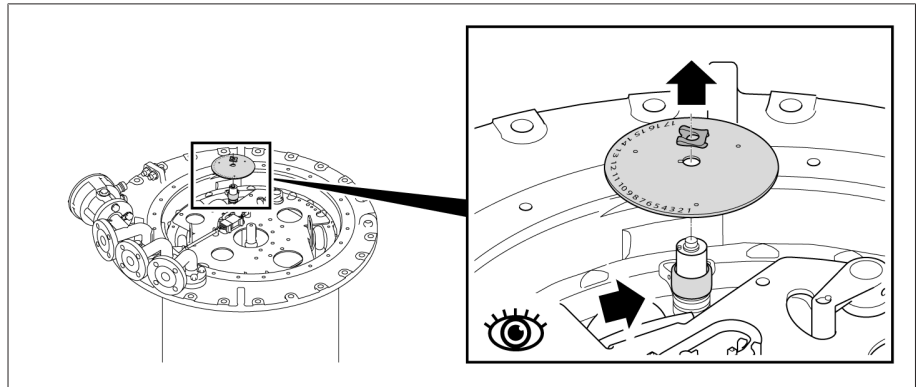

Figure 159: Tap position indicator disk

5.3.8.2.1.4 Removing tap position indicator disk with multiple coarse change-over selector with more than 35 operating positions

1. Ensure that the red marks on the panel, tap position indicator disk and cover disk produce a continuous red line.
2. Remove countersunk head screw.

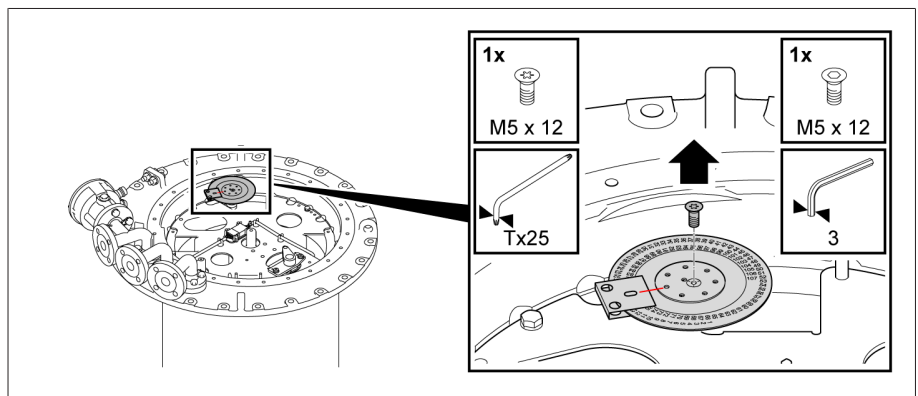

Figure 160: Countersunk head screw

3. Lever cover disk off underlying disk with flat screwdriver and pull out position-indication disk from between panel and bracket.

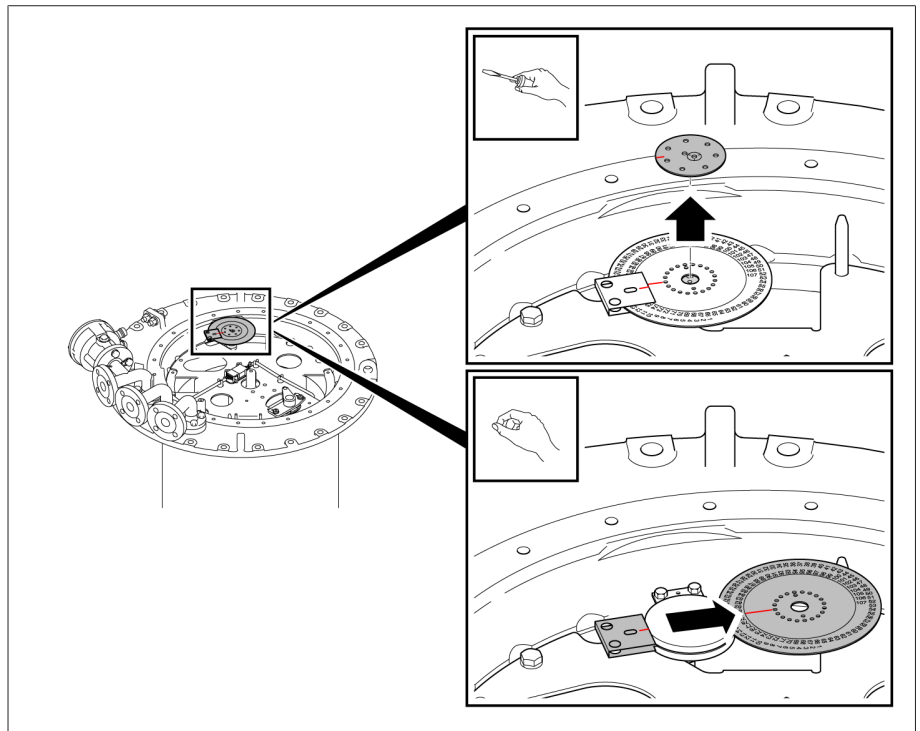

Figure 161: Cover disk and position-indication disk

4. Remove hexagon screws and associated lock tab.

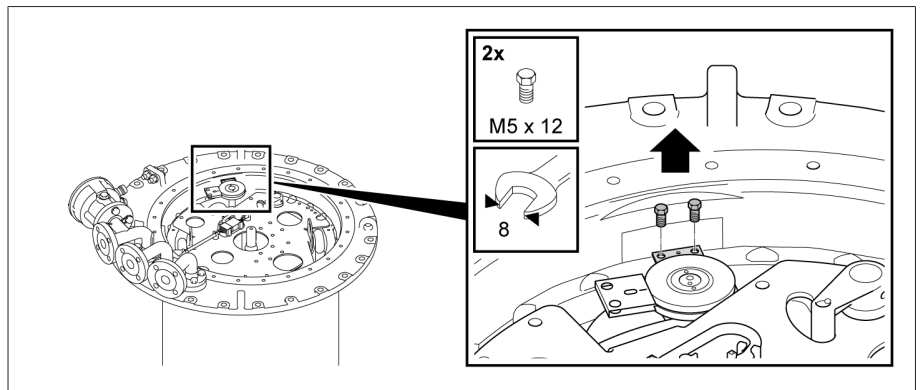

Figure 162: Lock tab

5. Pull panel and bracket up and off indicator drive shaft.

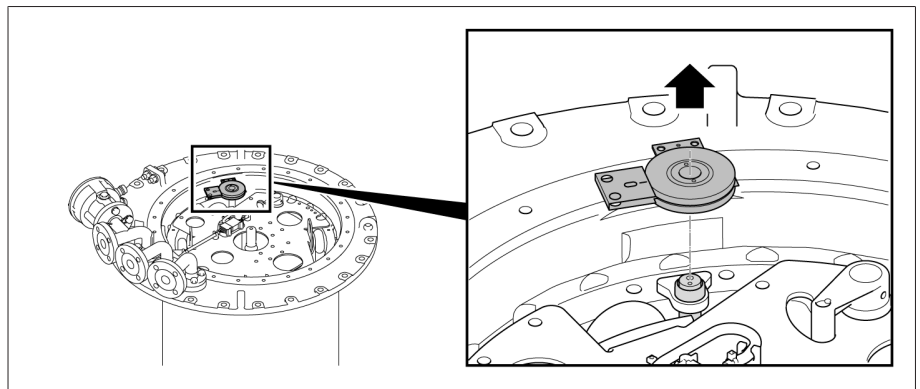

Figure 163: Panel

5.3.8.2.1.5 Disconnecting the plug connector of the tap-change supervisory control

⚠ DANGER



Electric shock!

If supply voltage is applied to the tap-change supervisory device, this can result in electric shock.

- > Disconnect the tap-change supervisory device from the supply voltage and secure it to prevent it from being switched back on again.

NOTICE

Damage to the tap-change supervisory device!

Disconnecting the tap-change supervisory device without due care may damage it, thereby resulting in damage to the on-load tap-changer.

- > Disconnect the tap-change supervisory device with care in order not to damage or rip out the connecting leads.

1. Lift plug connector and leads out of bracket and retaining clamps.

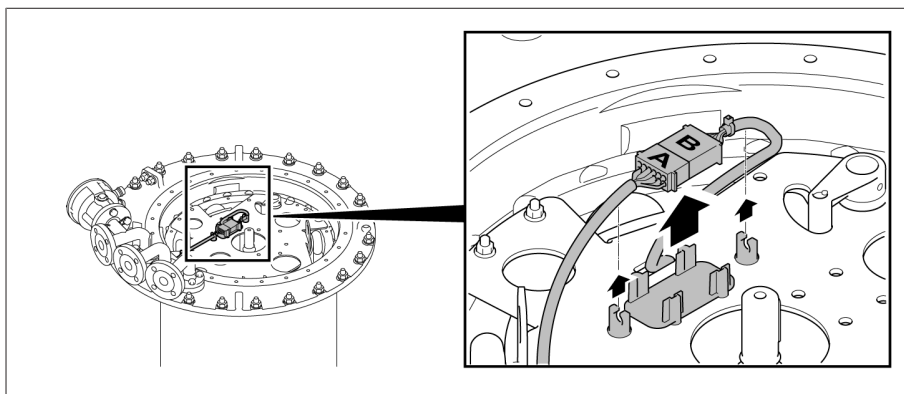

Figure 164: Lifting out plug connector

2. Disconnect the plug connector.

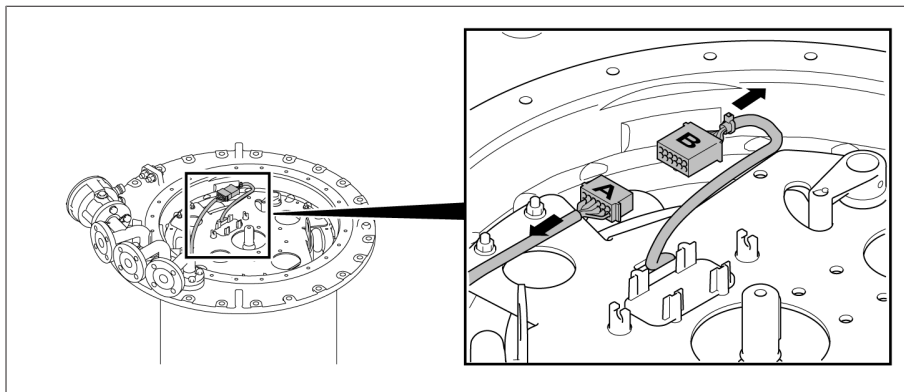

Figure 165: Disconnecting plug connector

3. Put part B of plug connector back in bracket.

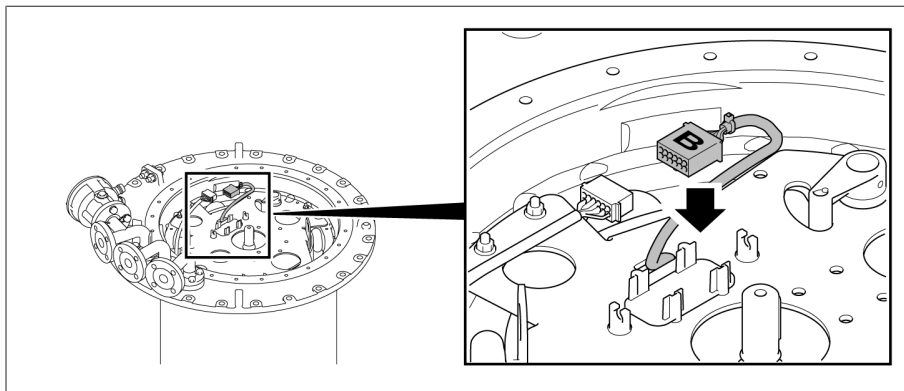

Figure 166: Placing part B of plug connector in bracket

- Swivel part A of plug connector out of on-load tap-changer head in direction indicated by arrow until it is between the pipe connections and the cable cannot be damaged when pulling out the diverter switch insert.

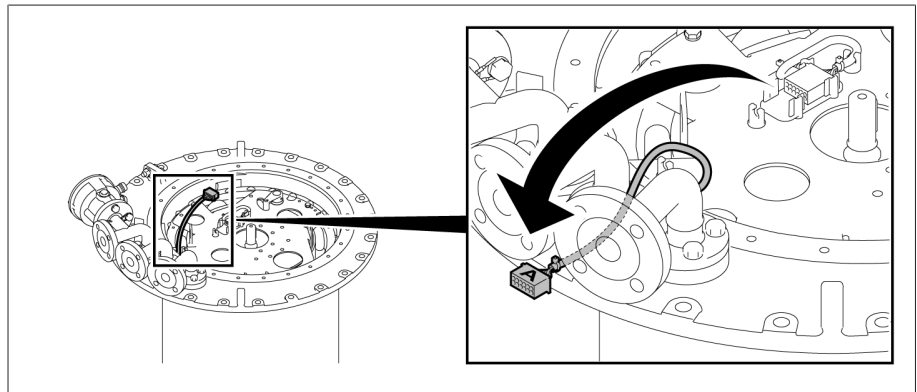

Figure 167: Swiveling out part A of plug connector

5.3.8.2.1.6 Lifting out diverter switch insert

- Remove attachment and locking elements on carrier plate of diverter switch insert.

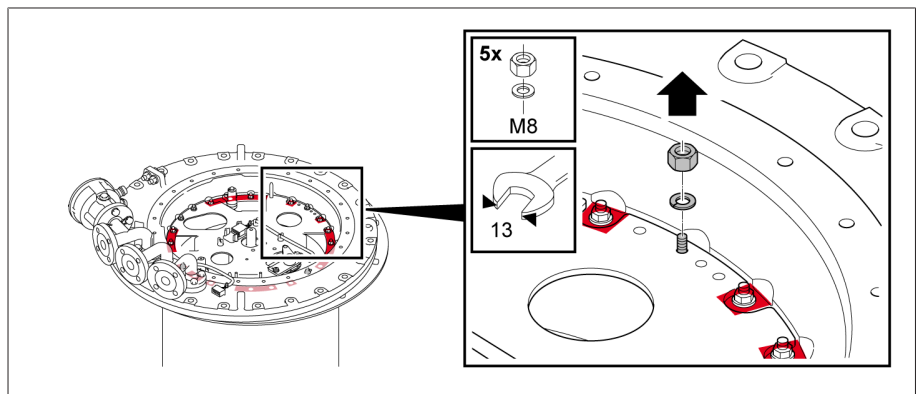

Figure 168: Carrier plate of diverter switch insert

- Insert lifting gear in the brackets on the diverter switch insert carrier plate and position vertically above the diverter switch insert.

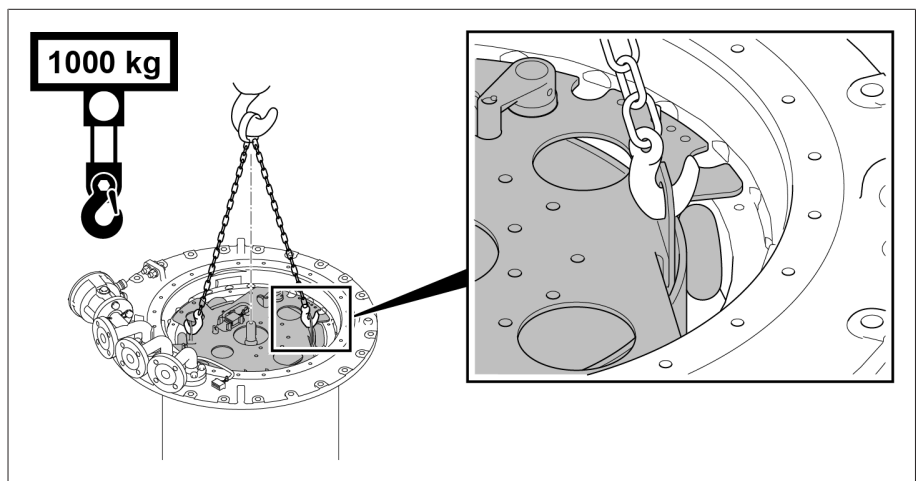

Figure 169: Brackets on carrier plate

3. Lift out diverter switch insert slowly and vertically.

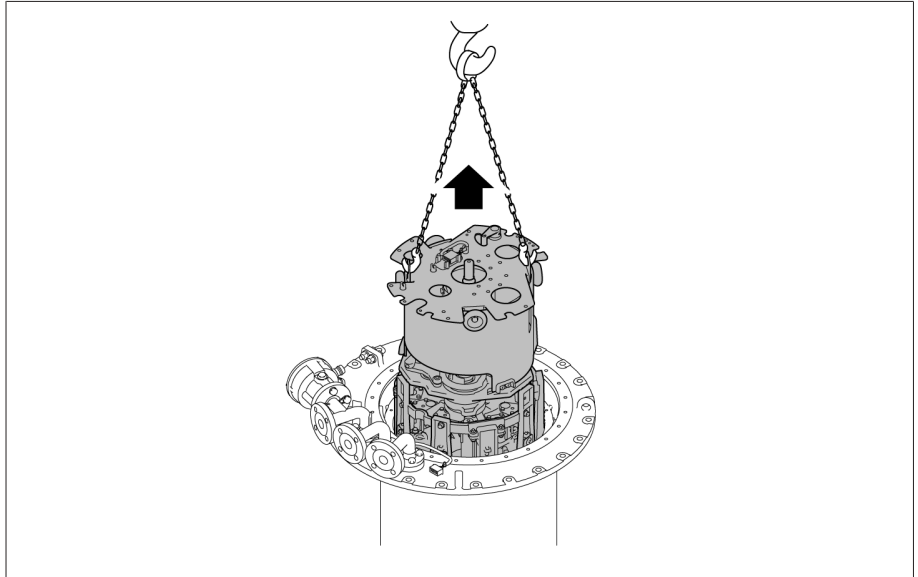

Figure 170: Lifting out diverter switch insert

4. **CAUTION!** An unstably positioned diverter switch insert may tip, resulting in injuries and property damage. Place the diverter switch insert on a level surface and secure it against tipping.
5. Note down whether the diverter switch insert is in the final end position on side A or side B. If the diverter switch insert is in the final end position on side A, the vacuum interrupter on side A is closed, and vice versa. In the example in the appendix, the diverter switch insert is in the final end position on side B.

5.3.8.2.2 Opening kerosene drain plug

- > **NOTICE!** Never remove the kerosene drain plug completely. Unscrew kerosene drain plug with extended socket wrench counter-clockwise until it starts to become hard to open.

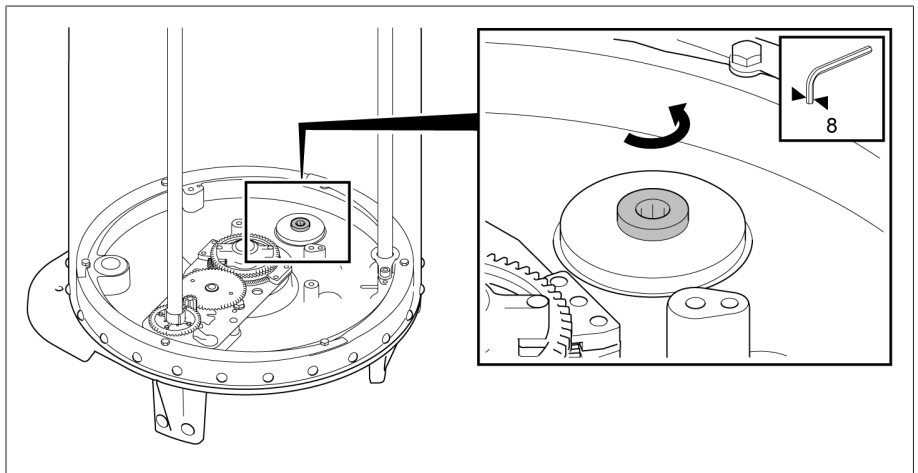

Figure 171: Kerosene drain plug

5.3.8.2.3 Inserting diverter switch insert

5.3.8.2.3.1 Inserting diverter switch insert

1. To fit diverter switch insert, ensure that selector coupling and indicator gear are in the adjustment position.

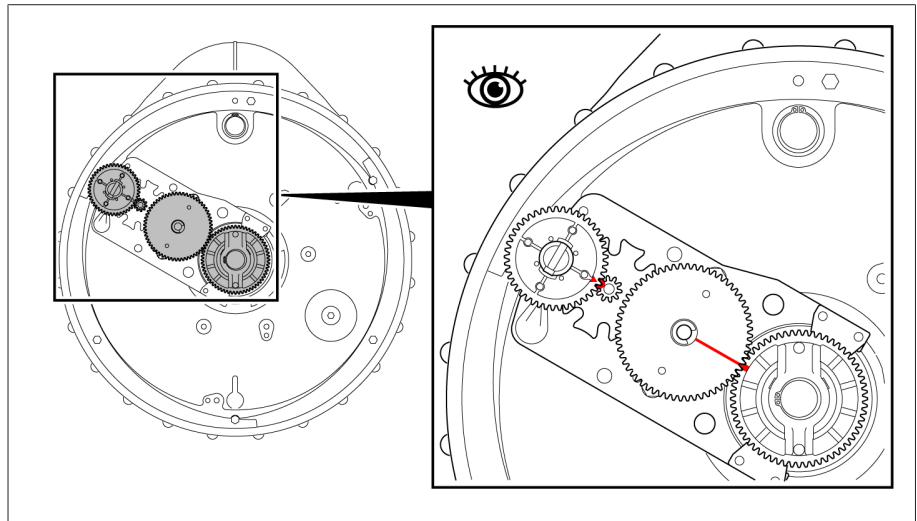

Figure 172: Adjustment position

2. Insert lifting gear in the brackets provided on the diverter switch insert carrier plate and position vertically above the diverter switch insert.

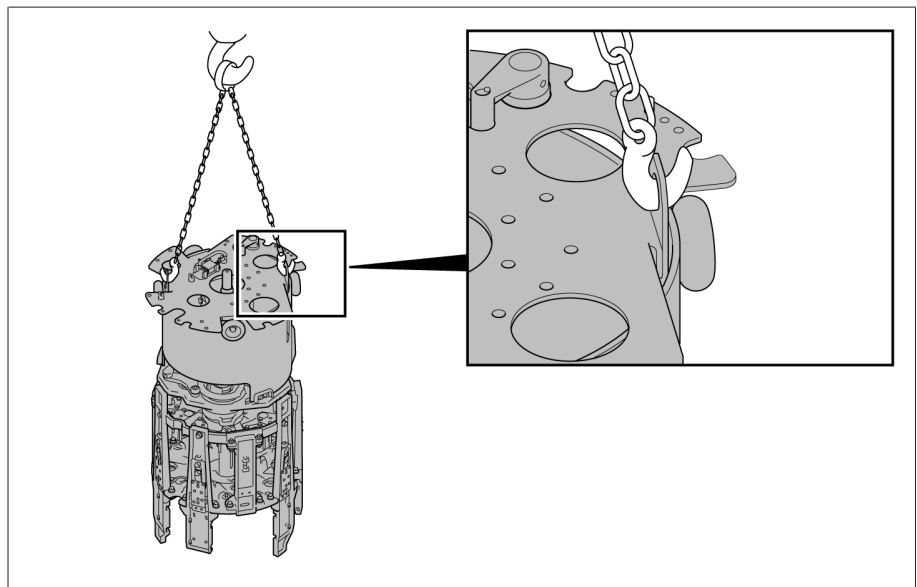

Figure 173: Brackets on carrier plate

3. Ensure that diverter switch insert is in the final end position on the same side as when it was removed (side A or side B). The vacuum interrupter is closed on the side that is in the final end position. In the example in the appendix, side B is in the final end position, see appendix.

- By turning the coupling tube, align it in such a manner that the red triangles on the coupling tube and carrier plate match up.

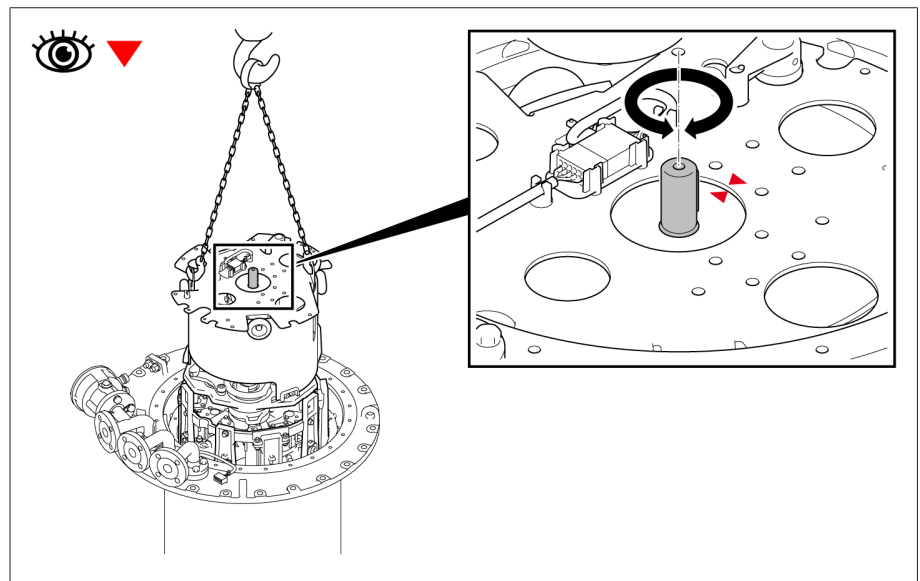

Figure 174: Coupling tube

- NOTICE!** Mixing up the diverter switch inserts will lead to damage to the on-load tap-changer. Ensure the same number of triangles on the top of the energy accumulator and on-load tap-changer head.
- Align diverter switch insert such that the red triangles at the top of the energy accumulator and on the on-load tap-changer head are opposite one another. Slowly lower diverter switch insert.

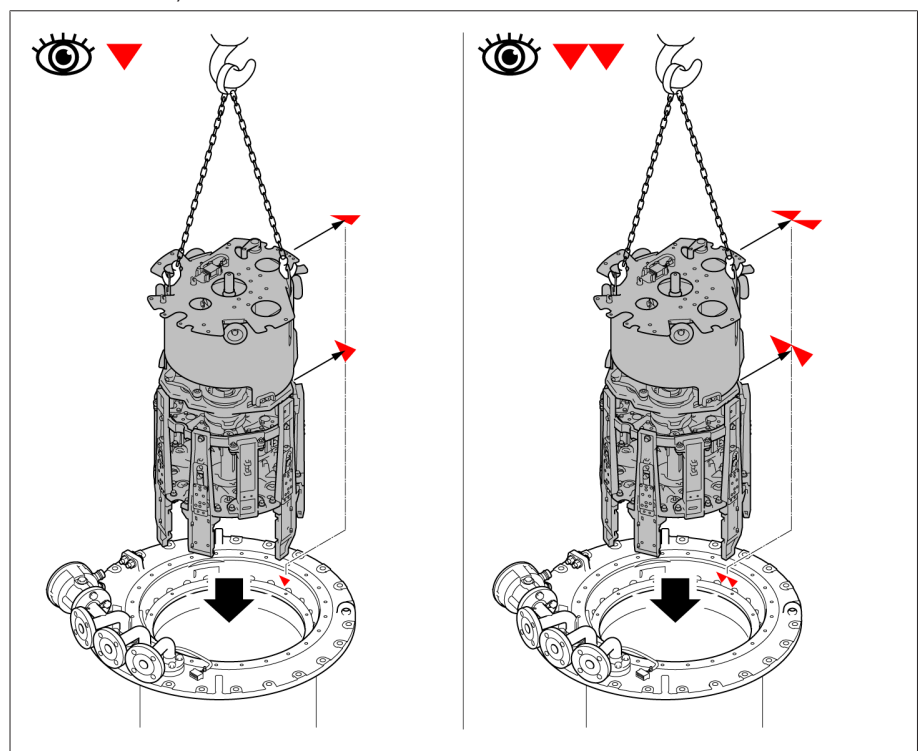

Figure 175: Aligning diverter switch insert

- Slowly lower diverter switch insert.
- Ensure correct position of carrier plate in on-load tap-changer head. Area marked red must remain free.

9. Secure carrier plate of diverter switch insert.

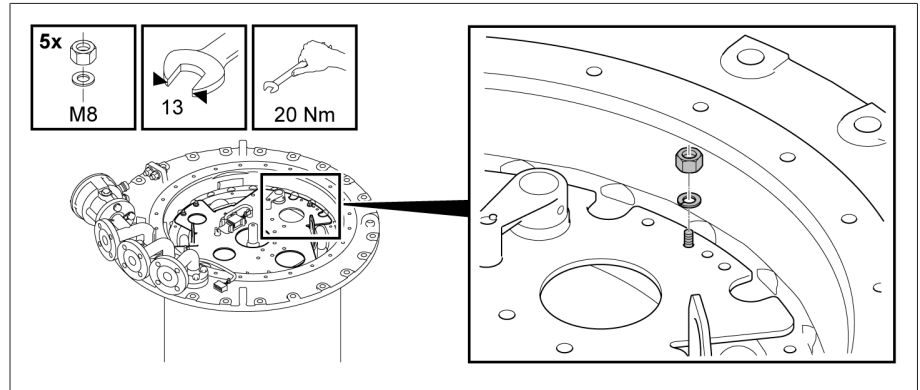

Figure 176: Carrier plate of diverter switch insert

5.3.8.2.3.2 Connecting plug connector of the tap-change supervisory device

1. Lift part B of plug connector out of bracket.

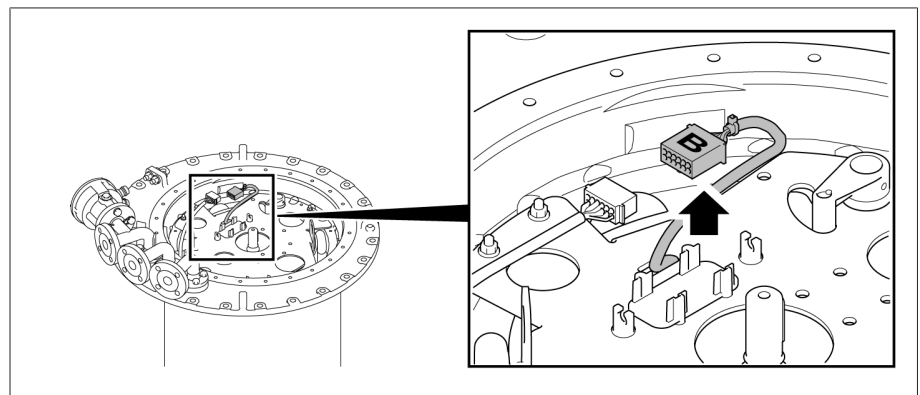

Figure 177: Part B of plug connector

2. Connecting plug connector

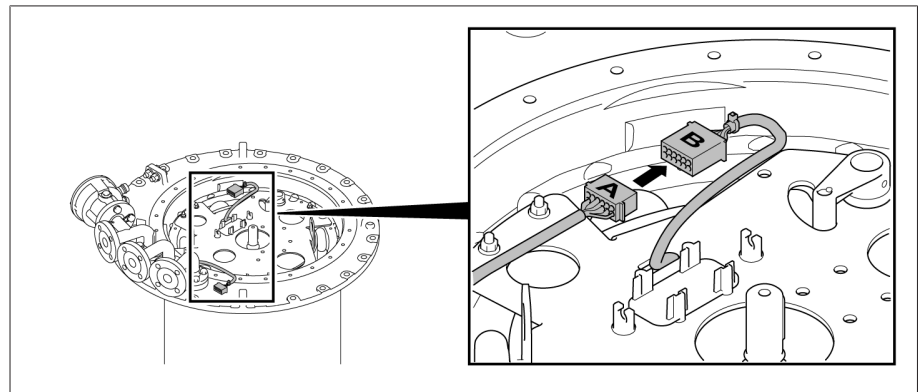

Figure 178: Connecting plug connector

- Place plug connector in bracket, secure leads on both sides of plug connector in retaining clamps.

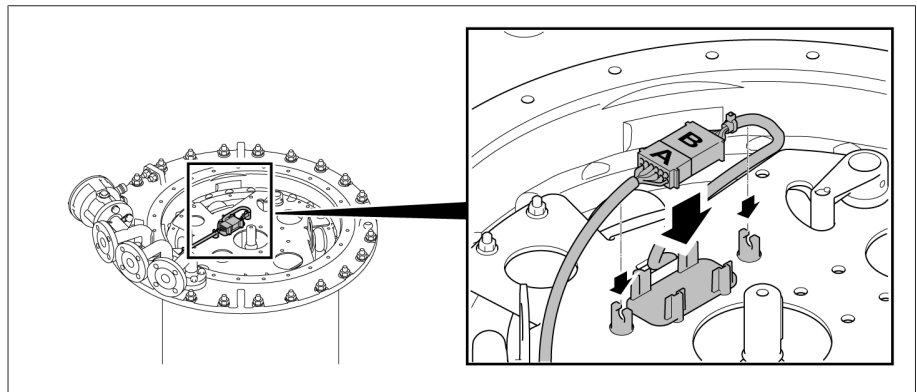

Figure 179: Placing plug connector in bracket

5.3.8.2.3.3 Inserting the tap position indicator without multiple coarse change-over selector



Due to the coupling pin, the tap position indicator disc can only be installed when in the correct position.

- Place tap position indicator disk on indicator drive shaft, slide spring clip on to shaft end.

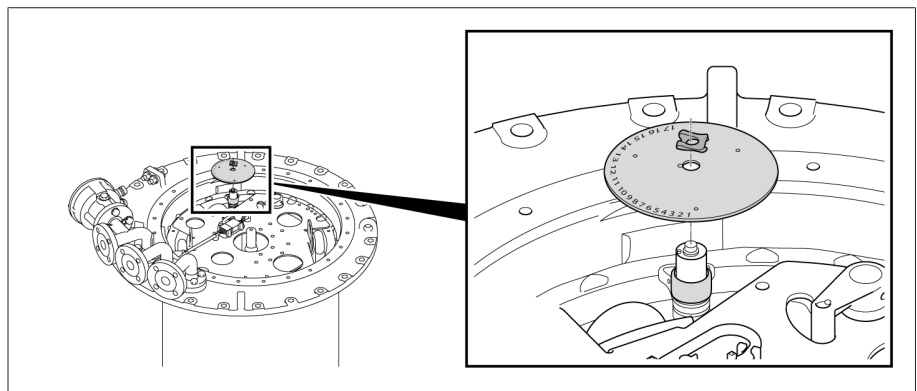

Figure 180: Tap position indicator disk

5.3.8.2.3.4 Inserting tap position indicator with multiple coarse change-over selector with more than 35 operating positions

- Place panel with bracket on indicator drive shaft and fasten with hexagon screws and associated lock tab.

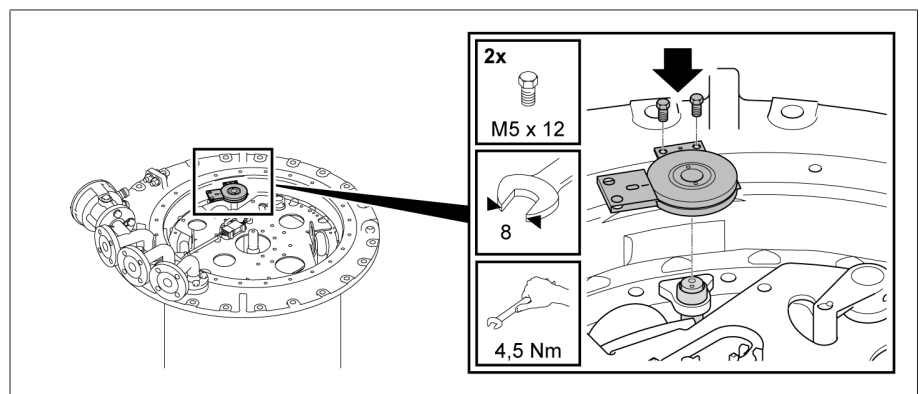

Figure 181: Fitting panel

2. Insert position-indication disk horizontally between panel and bracket and fit cover disk. Align tap position indicator disc and cover disk to produce a continuous red line.

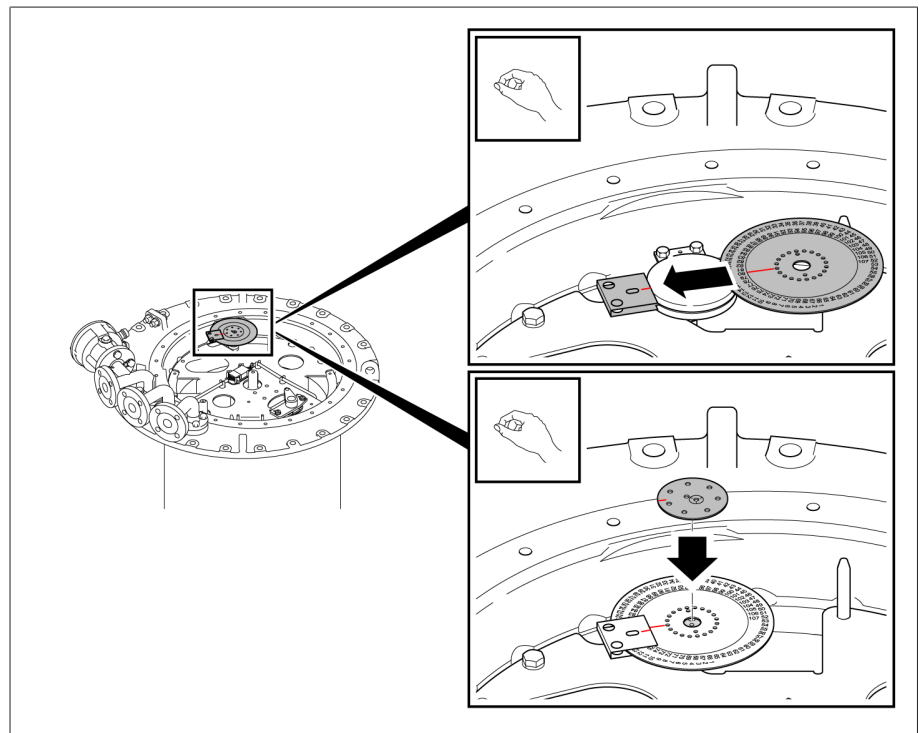

Figure 182: Inserting position-indication disk

3. Secure cover disk with countersunk head screw. The countersunk head screw must be suitable for center-punching.

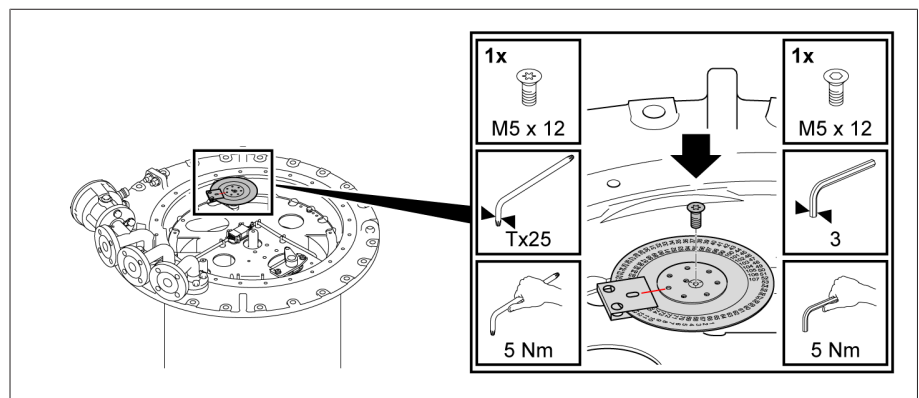

Figure 183: Fastening cover disk

4. Secure countersunk head screw by center-punching.

5.3.8.2.3.5 Securing on-load tap-changer head cover

NOTICE

Damage to the on-load tap-changer!

A missing or damaged o-ring as well as unclean sealing surfaces lead to insulating fluid escaping and therefore to damage to the on-load tap-changer.

- > Ensure that the o-ring is positioned untwisted in the on-load tap-changer head cover.
- > Ensure that the o-ring does not become damaged when mounting the cover.
- > Ensure that the sealing surfaces on the on-load tap-changer head cover and on-load tap-changer head are clean.

1. Check that the feather key is securely positioned in the adapter shaft. Where necessary, use Vaseline to secure the feather key against falling out.

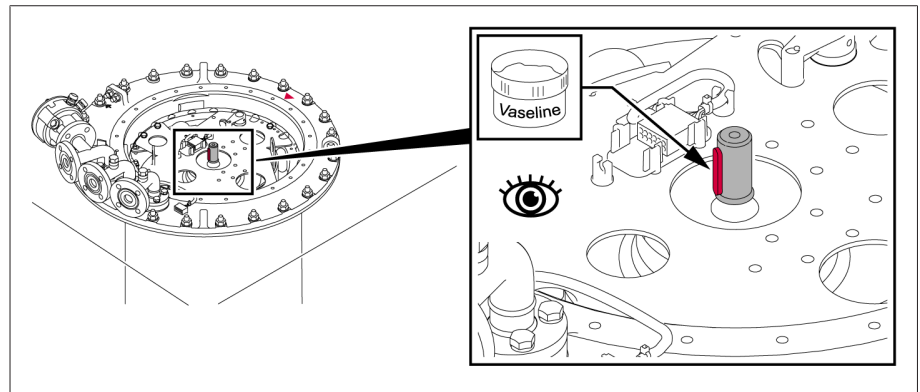

Figure 184: Feather key

2. Position the on-load tap-changer head cover on the on-load tap-changer head in such a way that the red triangular markings on the on-load tap-changer head and the on-load tap-changer head cover are aligned.

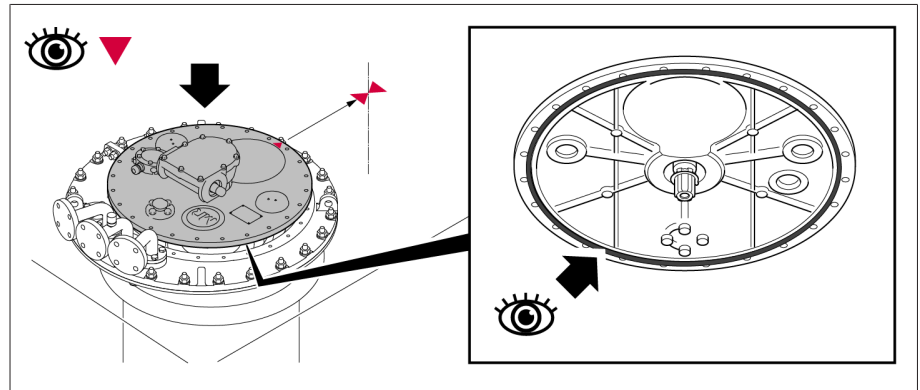

Figure 185: Triangular markings and o-ring

3. Screw the on-load tap-changer head cover onto the on-load tap-changer head.

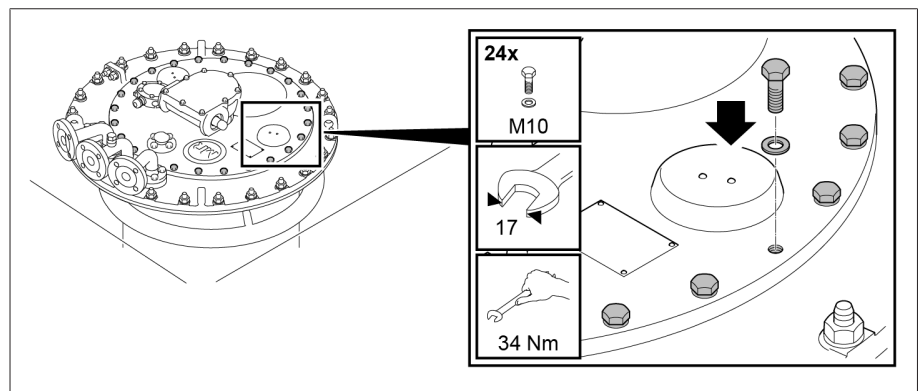

Figure 186: On-load tap-changer head cover

5.3.8.2.4 Drying the on-load tap-changer

1. Connect pipe connections R and Q of on-load tap-changer head to the kerosene vapor lead using one shared lead.
2. Seal off unused pipe connections with a suitable blank cover.

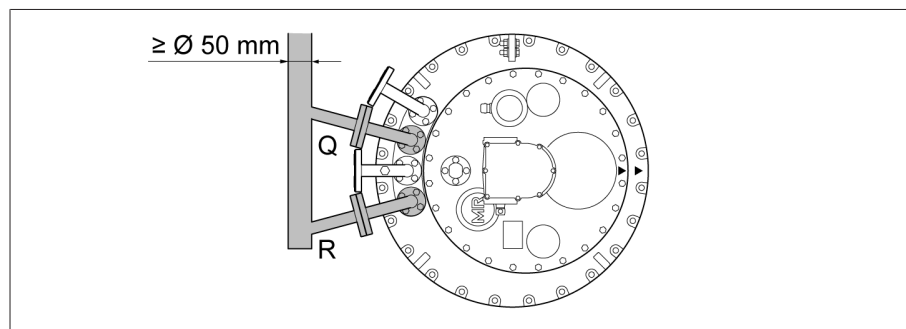

Figure 187: Shared lead

Vapor-phase drying in the transformer tank

1. Supply kerosene vapor at a temperature of around 90°C. Keep this temperature constant for 3 to 4 hours.
2. Increase the kerosene vapor temperature by approx. 10°C/hour to the desired final temperature of max. 125°C at the on-load tap-changer.
3. Vacuum-dry on-load tap-changer at between 105°C and maximum 125°C for at least 50 hours.
4. Residual pressure of no more than 10⁻³ bar.

5.3.8.2.5 Closing kerosene drain plug

NOTICE

Damage to the on-load tap-changer!

Moisture in the oil compartment reduces the dielectric strength of the insulating fluid and thus leads to damage to the on-load tap-changer.

- > Within 10 hours of drying, seal off oil compartment with on-load tap-changer head cover.

1. Remove [▶ Section 5.3.8.2.1, Page 102] the diverter switch insert.
2. **NOTICE!** An open kerosene drain plug leads to insulating fluid escaping from the oil compartment and therefore to damage to the on-load tap-changer. Close kerosene drain plug by turning clockwise with extended socket wrench (tightening torque 20 Nm).
3. Insert [▶ Section 5.3.8.2.3, Page 109] the diverter switch insert.



If you wish to perform another transformer ratio test after drying, proceed as described in the section "Performing transformer ratio test following drying" [▶ Section 5.3.10, Page 117].

5.3.9 Filling the oil compartment of the on-load tap-changer with insulating fluid

NOTICE

Damage to the on-load tap-changer!

Unsuitable insulating fluids cause damage to the on-load tap-changer.

- > Only use insulating fluids [▶ Section 8.1.2, Page 198] approved by the manufacturer.

After drying, completely fill the oil compartment (diverter switch insert fitted) with insulating fluid again as soon as possible so that an impermissible amount of humidity is not absorbed from the surroundings.

1. Establish a connecting lead between pipe connection E2 and one of the pipe connections R, S or Q to ensure equal pressure in the oil compartment and transformer during evacuation.

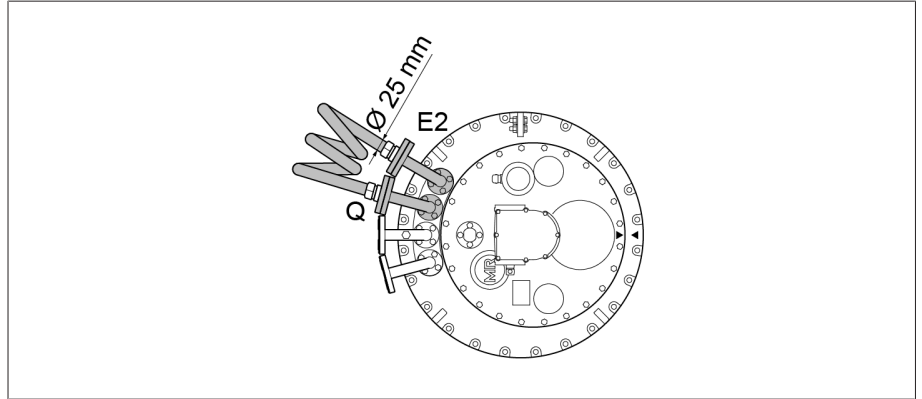

Figure 188: Connecting lead between E2 and Q

2. Fill on-load tap-changer with new insulating fluid using one of the two free pipe connections of the on-load tap-changer head.

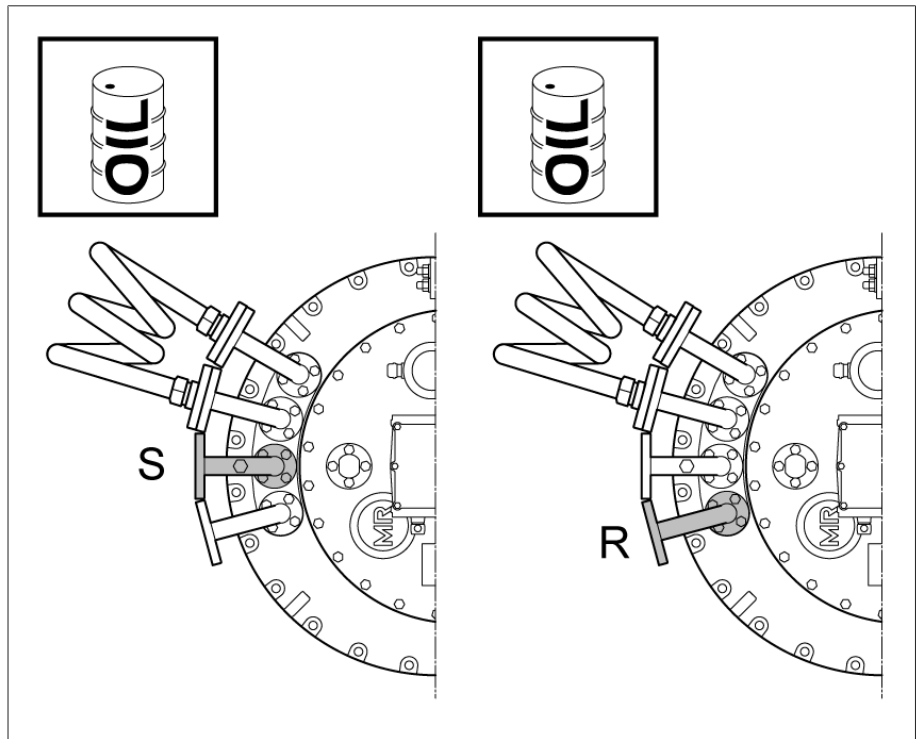

Figure 189: Pipe connections S and R

5.3.10 Performing transformer ratio test after drying

NOTICE

Damage to the on-load tap-changer!

Damage to the on-load tap-changer due to transformer ratio test being incorrectly performed.

- > Ensure that the selector / de-energized tap changer is fully immersed in the insulating fluid and that the oil compartment of the on-load tap-changer is completely filled with insulating fluid.
- > Only switch the on-load tap-changer from one operating position to the next via the upper gear unit. You can use a short tube (diameter 25 mm) with screwed-in coupling bolt (diameter 12 mm) with a hand wheel or crank for this, for example. When using a drill, do not exceed a maximum speed of 250 rpm.
- > Always check the operating position reached through the inspection window in the on-load tap-changer head cover. Never overshoot the end positions, which are indicated in the connection diagram supplied with the delivery.
- > For multiple-column applications with a shared drive, link all on-load tap-changer heads to one another using the horizontal drive shaft part.



When actuating the change-over selector, a higher torque is required.

1. Switch the on-load tap-changer into the desired operating position. The diverter switch operation can be heard distinctly.
2. **NOTICE!** An incomplete tap-change operation may damage the on-load tap-changer. After operating the diverter switch, continue to crank the drive shaft of the upper gear unit for 2.5 revolutions in the same direction in order to correctly complete the tap-change operation.
3. Perform the transformer ratio test.
4. Repeat the transformer ratio test in all operating positions.
5. Switch the on-load tap-changer into adjustment position (see the accompanying connection diagram for the on-load tap-changer).

5.4 Fitting protective devices and drive components

5.4.1 Electrically connecting the temperature sensor

- Size the cable for the electrical connection of the temperature sensors such that you can turn the sensors if necessary when mounting the drive shaft.

- > Electrically connect the temperature sensors in accordance with the connection diagram provided.

5.4.2 Connecting the tap-change supervisory device

⚠ DANGER



Risk of fatal injury due to electrical voltage!

Danger of death due to electrical voltage when assembling and connecting the device.

- > De-energize the device and system peripherals and lock them to prevent them from being switched back on.
- > Connect monitoring contacts integrated into the on-load tap-changer head (terminal box on pipe connection Q) to the motor-drive unit terminals using a connecting lead as specified in the connection diagram provided.

5.4.3 Installing protective relay in piping and connecting

⚠ WARNING



Danger of explosion!

Explosive gases in the protective relay can deflagrate or explode and result in severe injury or death.

- > Wait 15 minutes after switching off the transformer before beginning further work on the protective relay so that the gases can dissipate.
- > Ensure that there are no ignition sources such as naked flames, hot surfaces or sparks (e.g. caused by the build-up of static charge) in the immediate surroundings and that none occur.
- > De-energize all auxiliary circuits before beginning work.
- > Do not operate any electrical devices during the work (e.g. risk of sparks from impact wrench).

- Always perform all transformer tests with the protective relay attached and connected.

5.4.3.1 Checking function of protective relay

Check the function of the protective relay before installing it in piping between on-load tap-changer head and oil conservator. The associated contact positions for checking electrical continuity are shown in the dimensional drawing provided.

1. Loosen the three screws on the terminal box cover and lift off the terminal box cover.

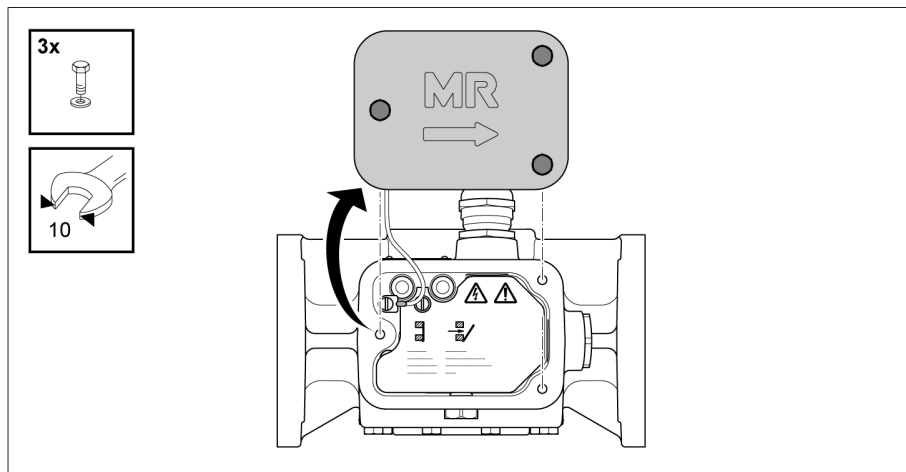

Figure 190: Terminal box cover

2. Remove the slotted head screw for potential tie-in and remove the terminal box cover with wire.

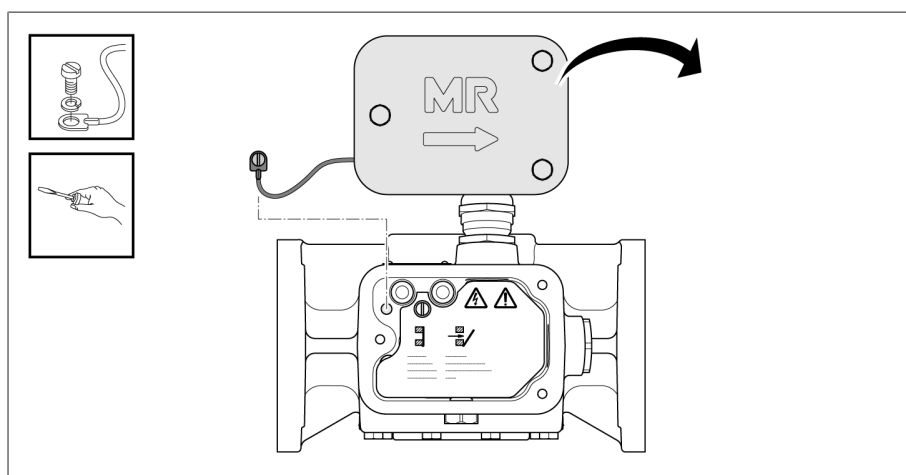

Figure 191: Terminal box cover

NOTICE

Damage to protective relay!

Damage to protective relay resulting from improper operation.

- > Never press both test buttons at the same time.

3. Press OFF test button.
 - » Flap valve is inclined. Line marker appears in the middle of the inspection window.

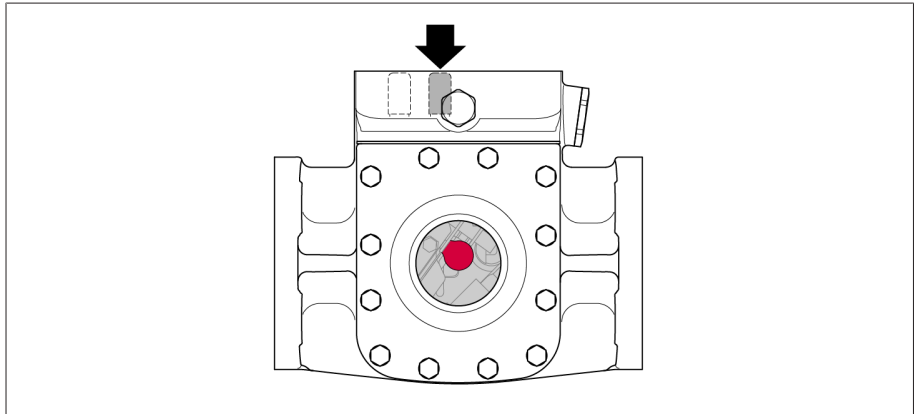

Figure 192: OFF position

4. Press OPERATION test button.
 - » Flap valve is vertical.

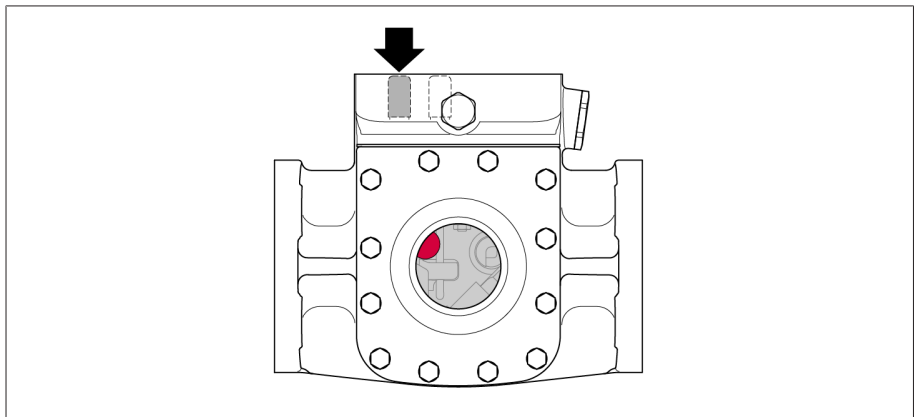

Figure 193: OPERATION position

5. Position the wire for the terminal box cover and affix using the slotted head screw.

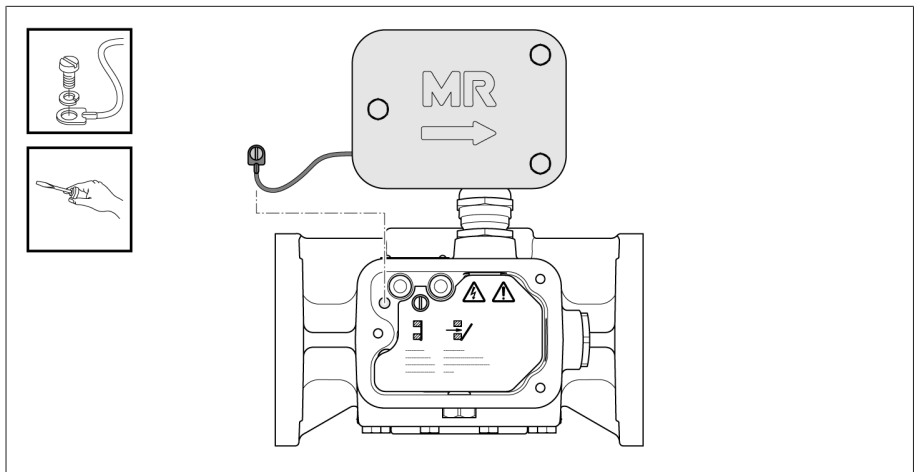

Figure 194: Terminal box cover

6. Attach the terminal box cover and secure with screws.

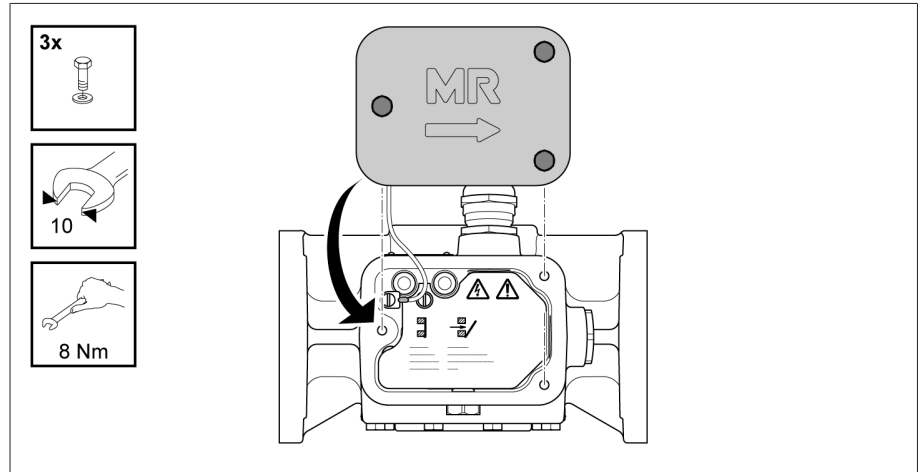

Figure 195: Terminal box cover

5.4.3.2 Installing protective relay in piping

Ensure the following for installation and proper function of the protective relay:

1. Ensure that there are no foreign bodies in the piping or in the oil conservator.
2. Install protective relay such that it can be easily accessed for subsequent maintenance work.
3. Install protective relay with good support and free from vibrations.
4. The test buttons must be at the top.
5. The interior diameter of the piping must be at least 25 mm.
6. The magnetic field strength (bushings, busbars etc.) must be $< 20 \text{ kA/m}$.
Higher field strengths have a negative effect on the function of the protective relay.
7. The piping from the protective relay to the oil conservator must be routed with an inclination of at least 2% (1.2°) to ensure the switching gases can escape freely.

8. The protective relay is intended for a horizontal operating position in close proximity to the on-load tap-changer head. A positive inclination of up to 5° from horizontal is permitted in the direction to the conservator. An inclination of up to 5° from vertical to either side is permitted.

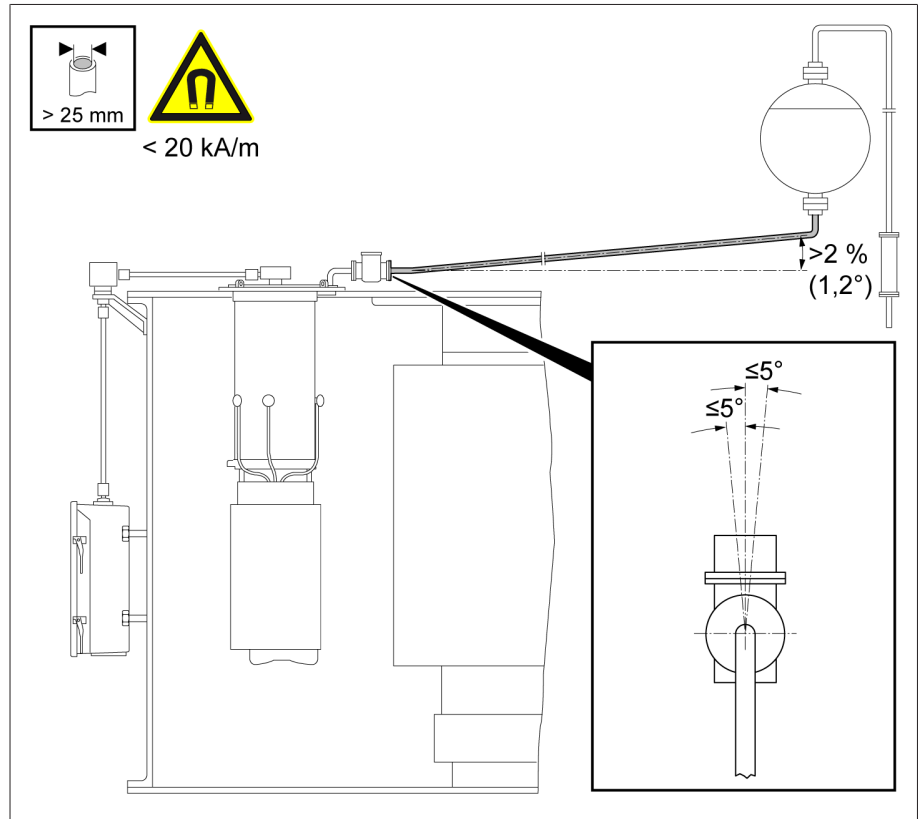

Figure 196: Protective relay installation

9. The reference arrow on the terminal box cover must point toward the on-load tap-changer's oil conservator.

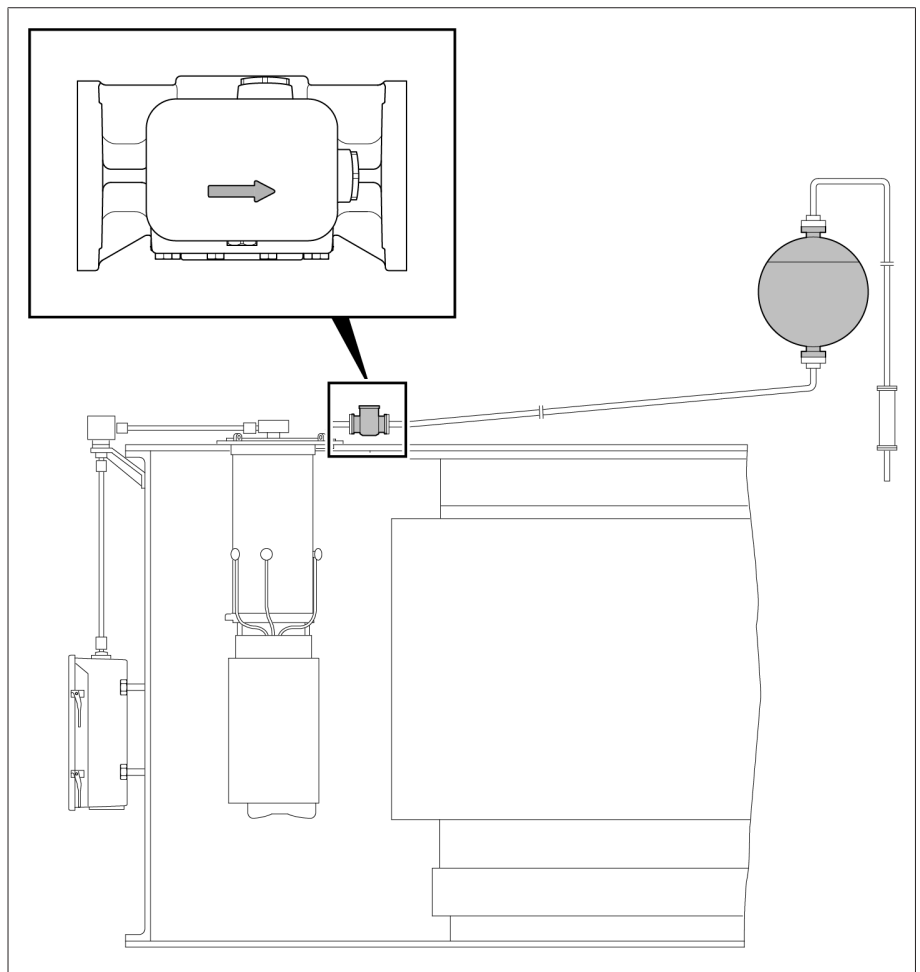

Figure 197: Reference arrow pointing towards the on-load tap-changer's oil conservator

10 Install a stop-cock with a nominal width of at least 25 mm between the protective relay and oil conservator.

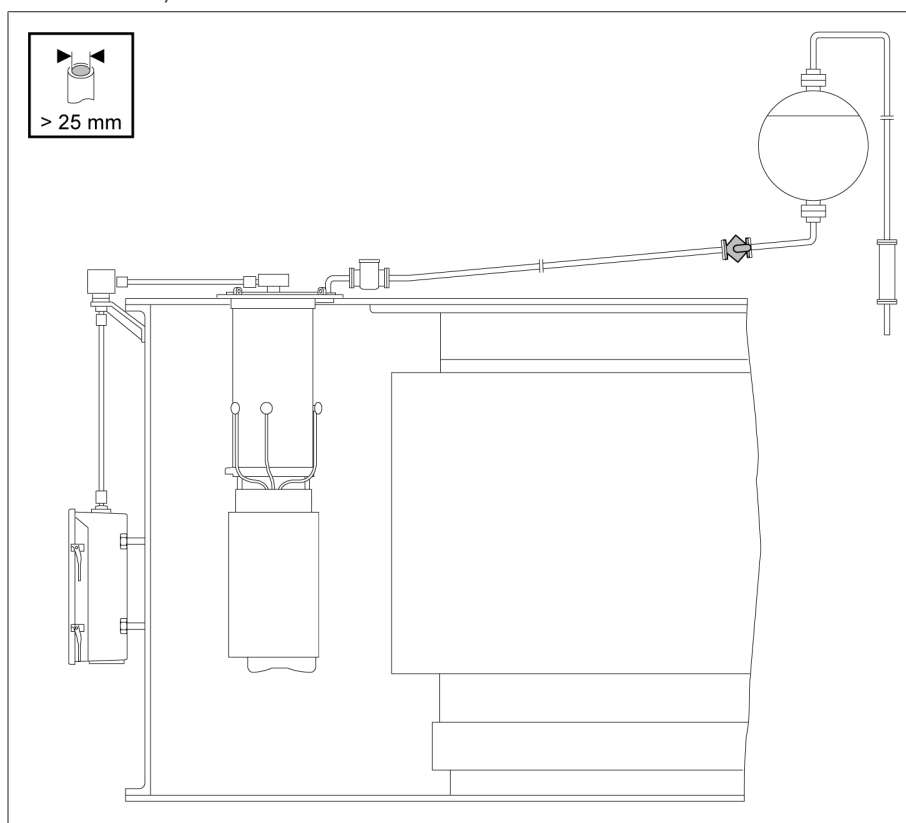

Figure 198: Stop-cock

5.4.3.3 Making the electrical connections for the protective relay

The protective relay's dry-reed magnetic switching tubes are supplied in the standard version as either NC or NO contacts. Other contact combinations can be supplied as special versions and are shown in the dimensional drawing provided.

▲ WARNING



Risk of death or severe injury!

Risk of death or severe injury due to improper electrical connection of the protective relay.

- > Loop the protective relay into the tripping circuit of the circuit breakers of the transformer to be protected so that the transformer is immediately de-energized by the circuit breakers when the protective relay is tripped.
- > Systems which only generate an alarm message are not permitted.

1. Insert cable gland (RS 2001, 2001/V, 2001/H, 2001/E, 2001/5, 2001/R) or adapter (RS 2003 and RS 2004) in the tapped hole with the most favorable position.

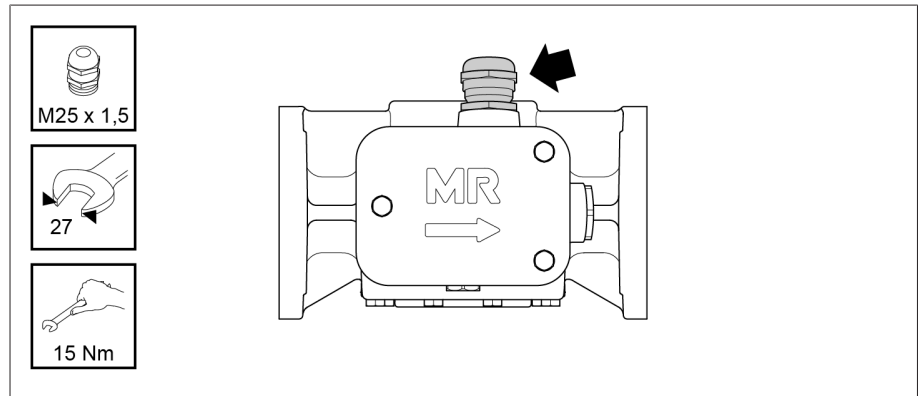

Figure 199: Tapped hole

2. Seal open tapped hole with dummy plug.

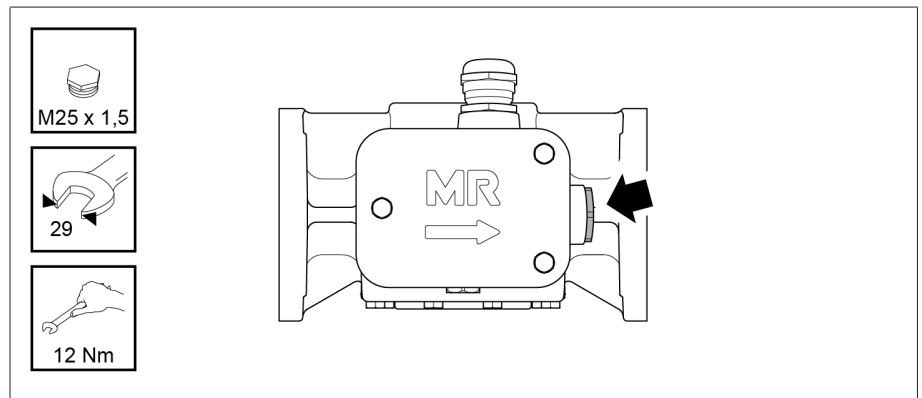

Figure 200: Sealed with dummy plug

3. Loosen the three screws on the terminal box cover and lift off the terminal box cover.

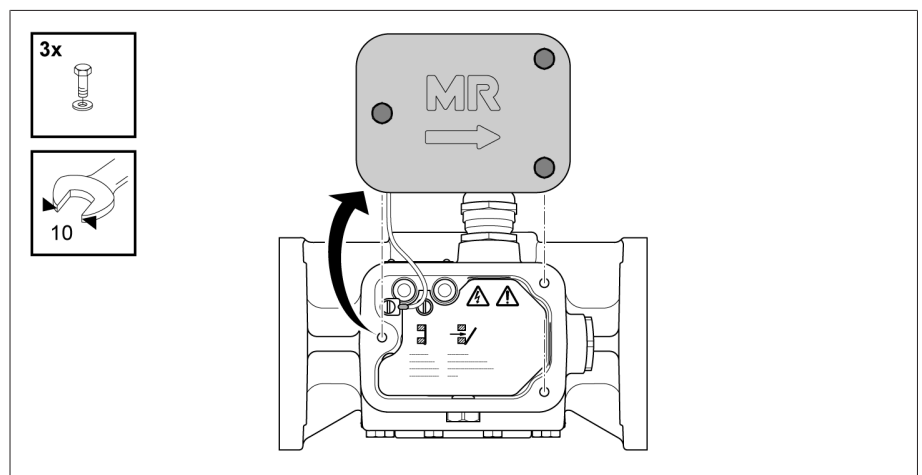

Figure 201: Terminal box cover

4. Take off the slotted head screw for potential tie-in and remove the terminal box cover with wire.

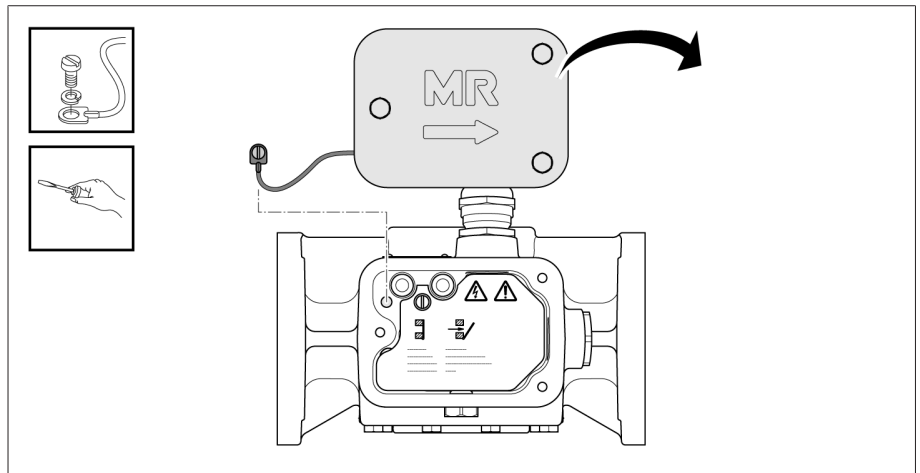

Figure 202: Terminal box cover

5. Remove screw for the protective cover and take off the protective cover.

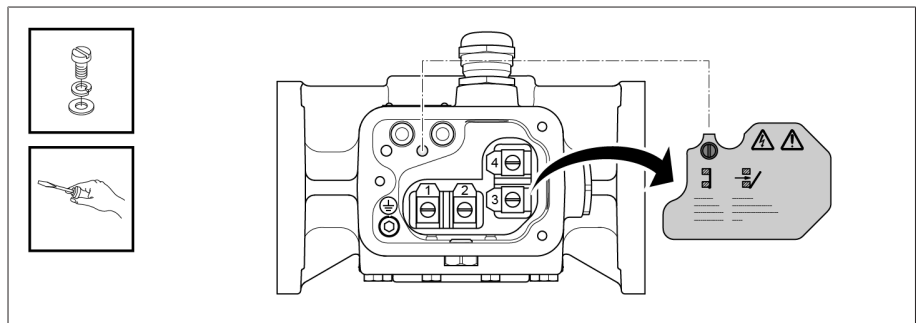

Figure 203: Protective cover

6. Guide cable through cable gland and into protective relay. Ensure that the cable gland is well connected and sealed.

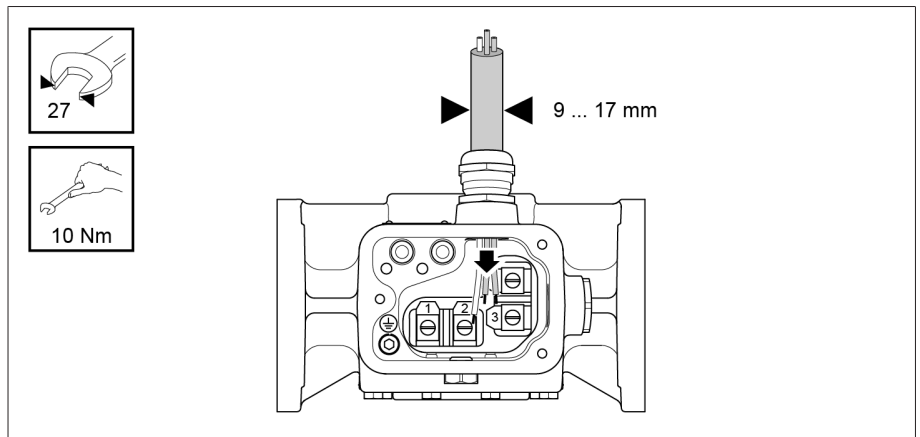

Figure 204: Cable bushing

7. Connect the electric cables to the connection terminals in accordance with the connection diagram on the dimensional drawing.

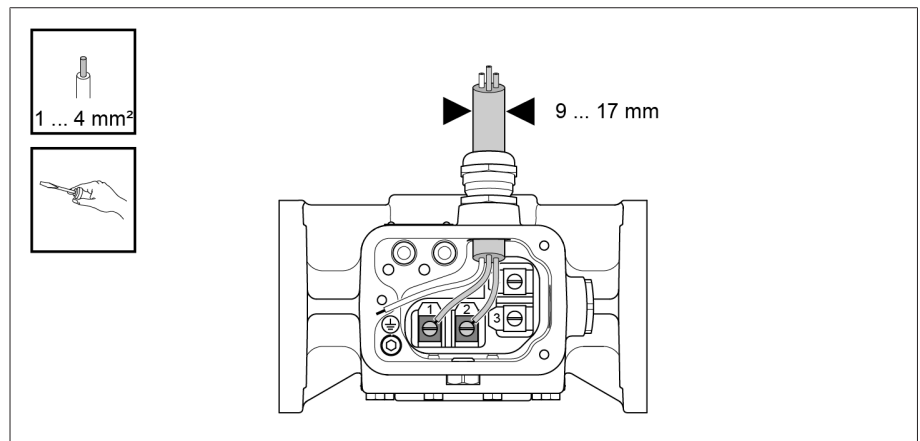

Figure 205: Electrical cables

8. Connect protective conductor to cylinder head screw.

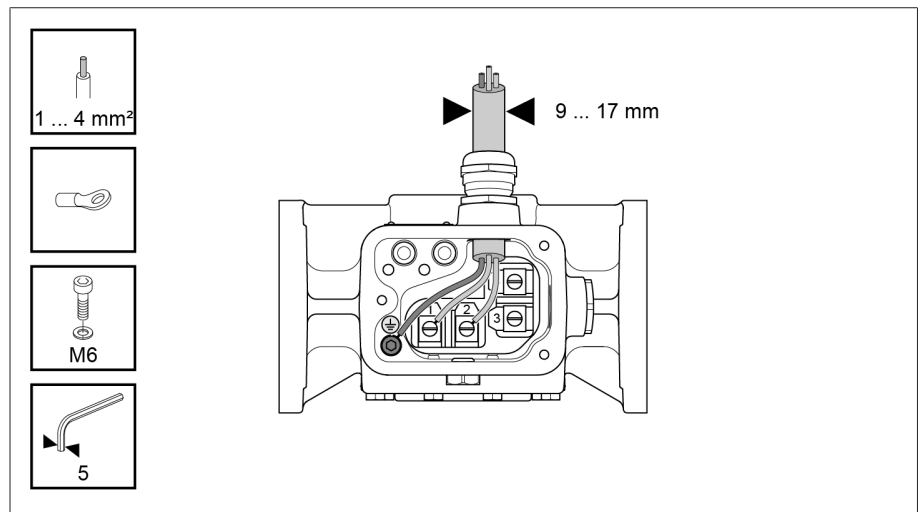

Figure 206: Protective conductor

9. Insert the protective cover and secure using the screw.

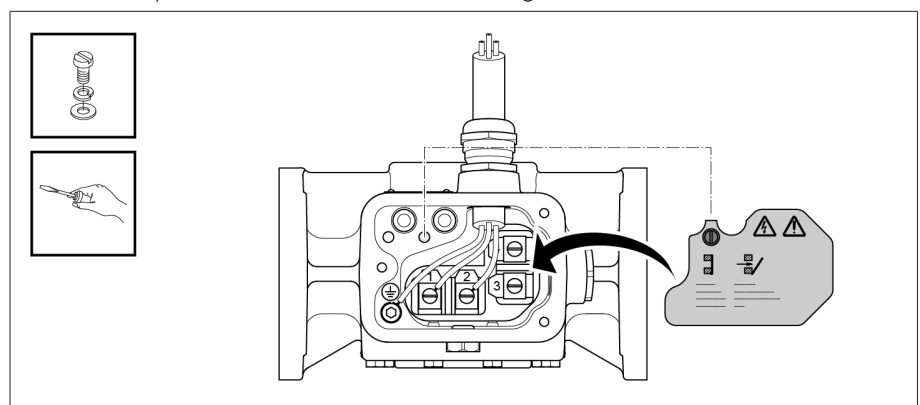

Figure 207: Protective cover

10. Position the wire for the terminal box cover and affix using the slotted head screw.

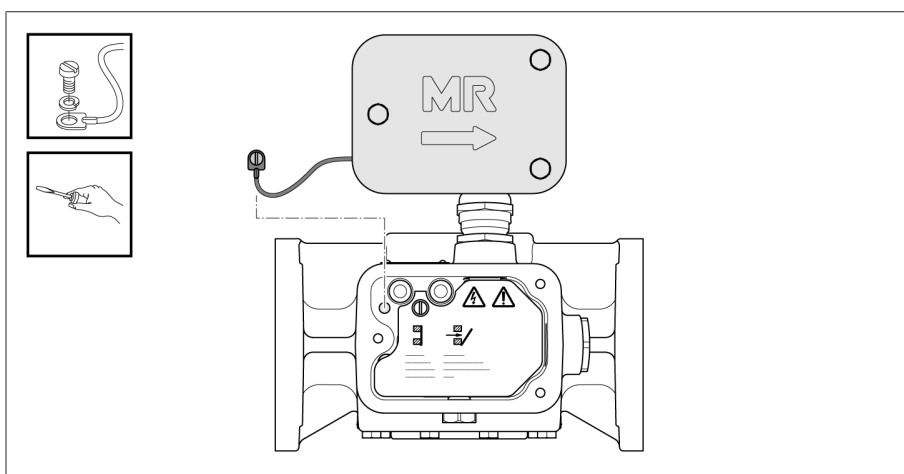

Figure 208: Terminal box cover

11. Attach the terminal box cover and secure with screws.

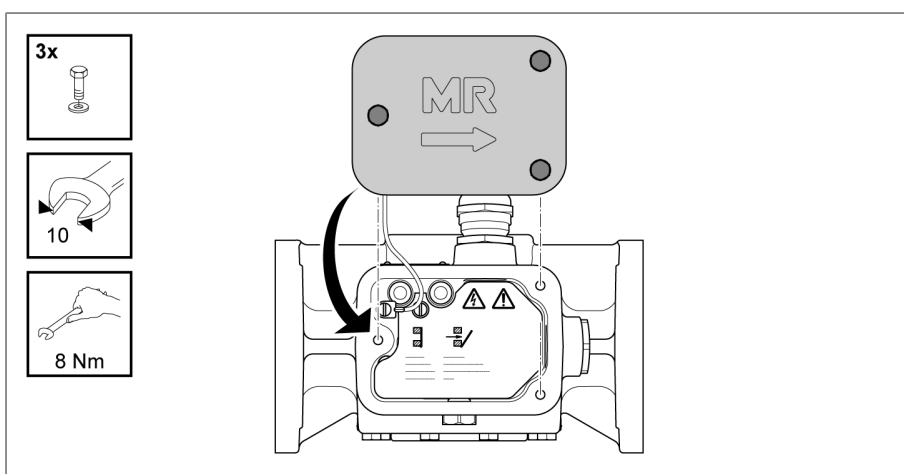

Figure 209: Terminal box cover

5.4.4 Installing and connecting the pressure monitoring device

5.4.4.1 Checking the function of the pressure monitoring device

Check the function of the pressure monitoring device before you install it on the pipe bend or the on-load tap-changer head.

1. Remove the cover cap.

2. Activate the snap-action switch.
» Sensor is in the OFF position above the snap-action switch.

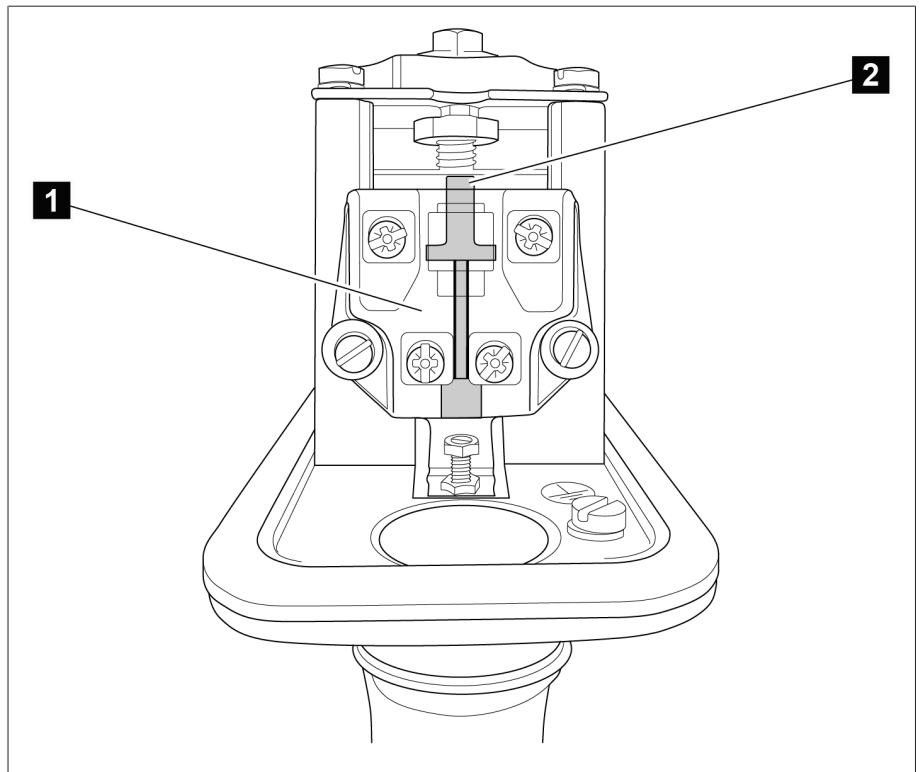

Figure 210: OFF position

1	Snap-action switch
2	Sensor in the OFF position

3. Activate the snap-action switch again.
 - » Sensor is in the OPERATION position below the snap-action switch.

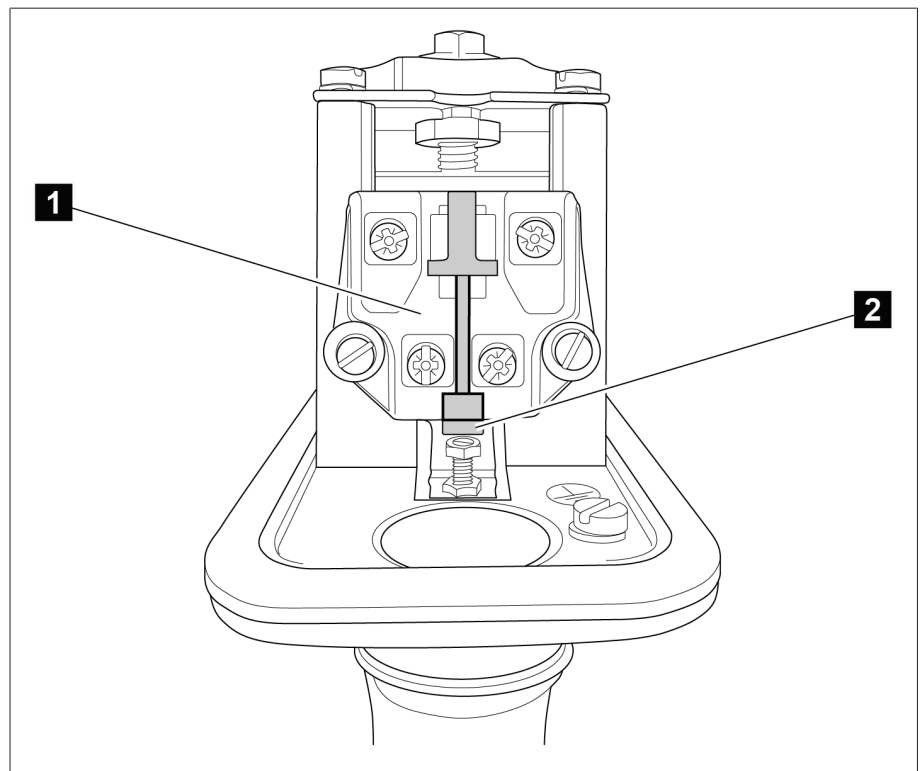

Figure 211: OPERATION position

1	Snap-action switch
2	Sensor in the OPERATION position

4. Secure the cover cap.

Always check the position of the sensor!

5.4.4.2 Installing the pressure monitoring device

The pressure monitoring device can be installed in 2 variants.

- Fastening on the on-load tap-changer head (vertical installation)
- Fastening onto the pipe bend (horizontal installation)

It is installed via the holes on the mounting ring. A mounting seal has to be installed under the pressure monitoring device during installation.

During fastening, ensure that the ventilation is on top.

Ensure that there is sufficient space above the pressure monitoring device to remove the cover cap.

5.4.4.3 Making the electrical connections for the pressure monitoring device

Risk of fatal injury due to electrical voltage!

⚠ DANGER



Danger of death due to electrical voltage when assembling and connecting the device.

- > De-energize the device and system peripherals and lock them to prevent them from being switched back on.

⚠ WARNING



Danger of death or severe injury!

Risk of severe injury or death due to improper electrical connection of the pressure monitoring device.

- > Loop the pressure monitoring device into the tripping circuit of the circuit breakers of the transformer to be protected so that the transformer is immediately de-energized by the circuit breakers when the pressure monitoring device is tripped.
- > Circuits which only generate an alarm message are not permitted.

1. Remove the cover cap.
2. Insert Use the tapped hole for routing leads for this.
3. Connect the leads to the terminals of the snap-action switch.
The snap-action switch is designed as a normally open and normally closed switch; it flips after being triggered and can be reset.
4. Connect all of the electrical leads and the protective conductor.
Either 1 or 2 leads can be connected per terminal for the lead connection (\varnothing 0.75...2.5 mm²).
5. Secure the cover cap.
6. Ensure the fixing screw is positioned correctly, see also dimensional drawing supplied.

5.4.5 Fitting motor-drive unit

- > Fit motor-drive unit to transformer as described in relevant MR operating instructions for motor-drive unit.

5.4.6 Fitting drive shaft

Observe the following during mounting:

Resistance to corrosion of components

The square tubes, coupling brackets, coupling bolts, screws, and locking washers are corrosion-resistant. We therefore recommend not applying the same external coating to these parts as to the transformer tank.

Cutting square tubes, telescopic protective tubes, and protective cover

The square tubes, the telescopic protective tube and the protective cover are supplied over-length (graded standard lengths). You must cut these parts to the required size before mounting on the transformer. In rare cases, you also have to cut the inner tube of the telescopic protective tube to the desired length. The maximum permitted total drive shaft length of the drive - last column = 15 m.

Standard lengths	Motor-drive unit	Manual drive
400	•	•
600	•	•
900	•	•
1300	•	•
1700	•	•
2000	•	•
2500	Not permitted	• ¹⁾

Table 6: Graded standard lengths of square tubes

¹⁾ |>2000 only possible for vertical installation without shaft protection! Telescopic protective tubes for manual drives with vertical dimensions V1> 2462 are to be supplied with vertical intermediate bearing, as with the motor-drive unit.

5.4.6.1 Fitting a vertical drive shaft without cardan joint

Permitted axial displacement

Minor axial displacements of the vertical drive shaft are permitted as long as they do not exceed 35 mm per 1000 mm of square tube length (this corresponds to 2°).

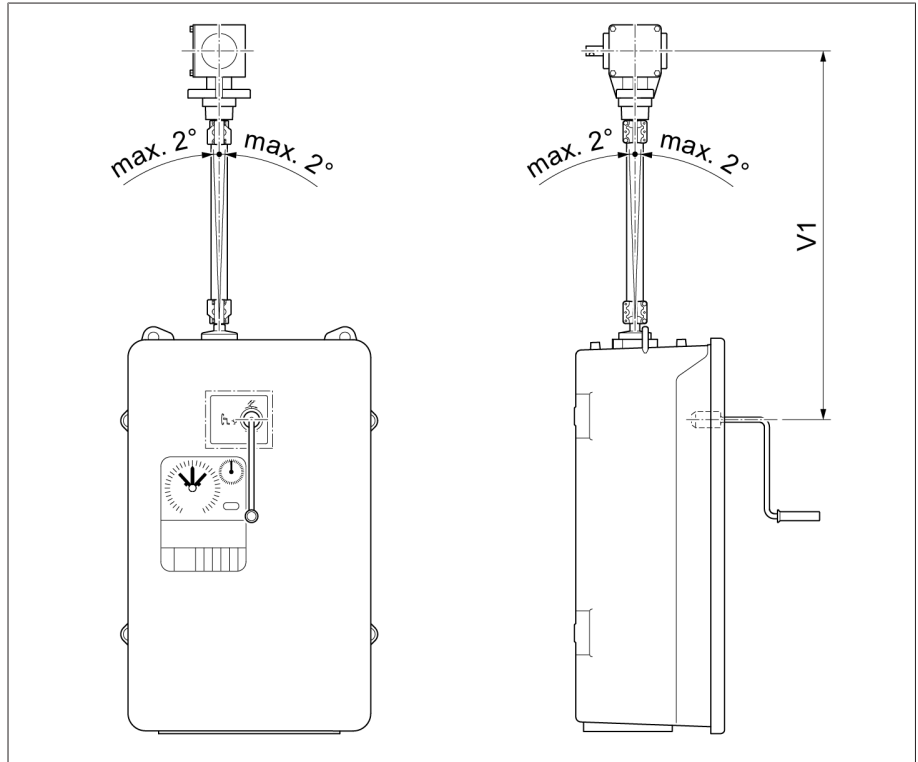

Figure 212: Permitted maximum axial displacement of vertical drive shaft without cardan joint

To fit the vertical drive shaft to the drive, proceed as follows:

1. **⚠ CAUTION!** Switch off motor protective switch Q1 in the motor-drive unit (position O). If this is not done, the motor-drive unit may be started inadvertently and cause injuries.
2. Fasten the bevel gear to the transformer.

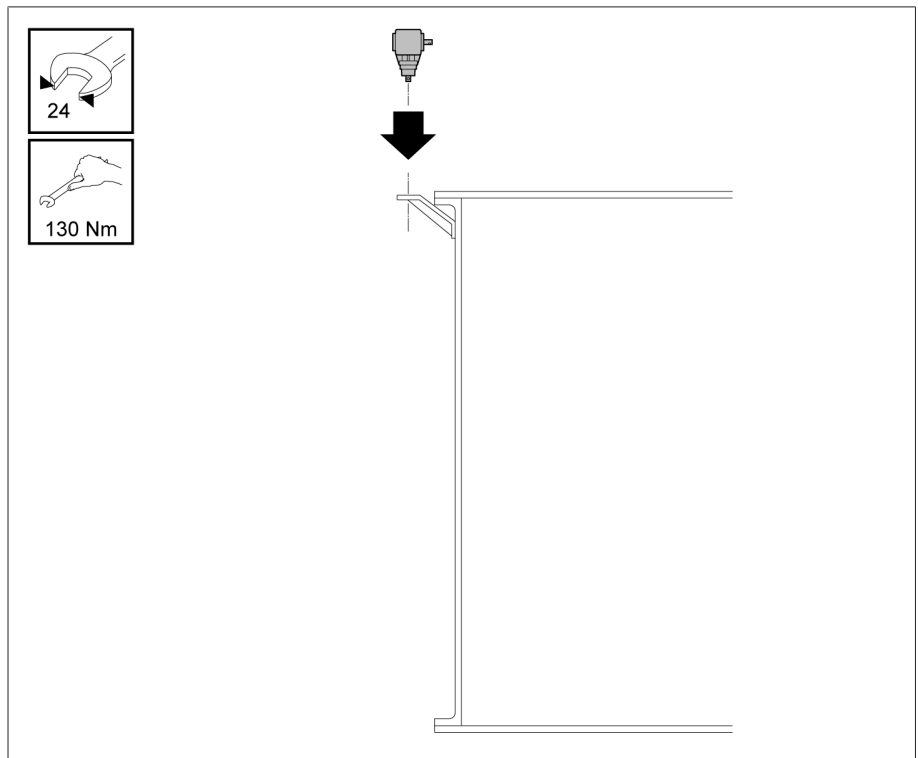

Figure 213: Bevel gear

3. Determine dimension A between shaft end of drive and shaft end of bevel gear. Shorten square tube to length of $A - 9$ mm.

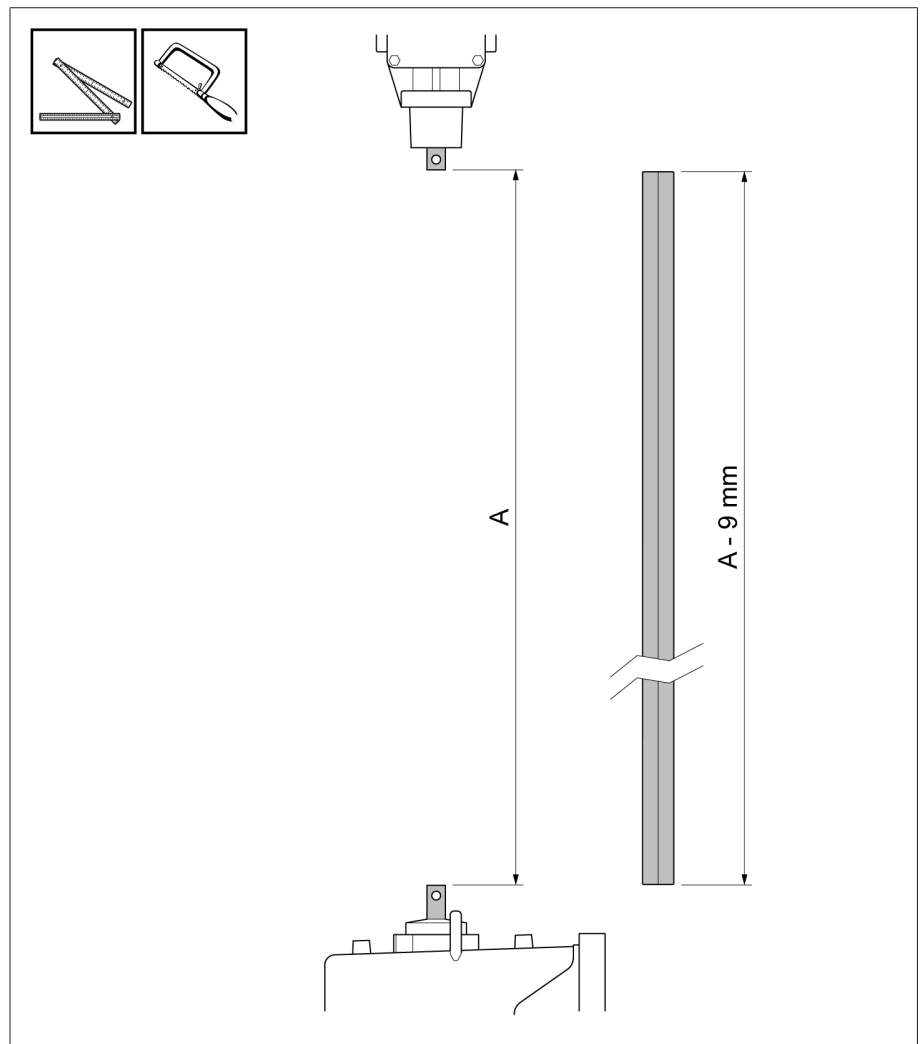

Figure 214: Shortening square tube

4. Deburr cut surfaces of square tube.

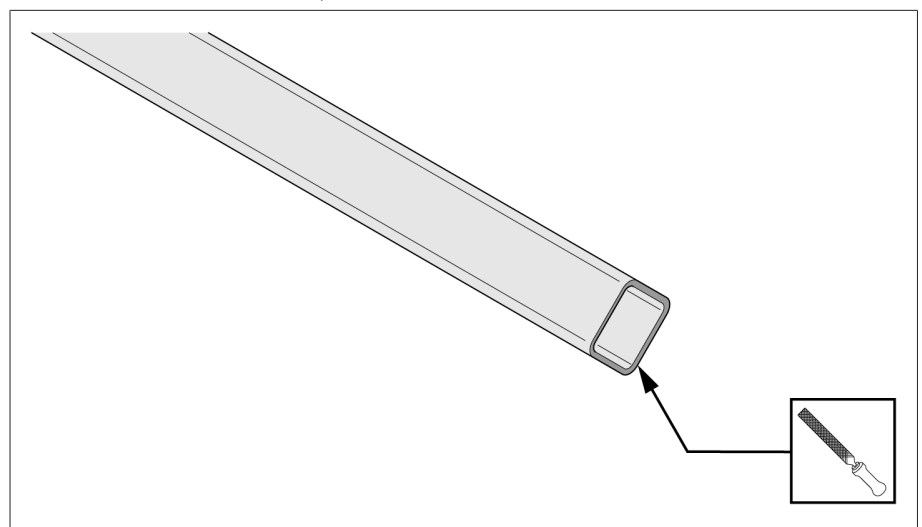

Figure 215: Deburring cut surfaces

5. Slide the loosely screwed-together coupling part onto square tube until stop is reached.

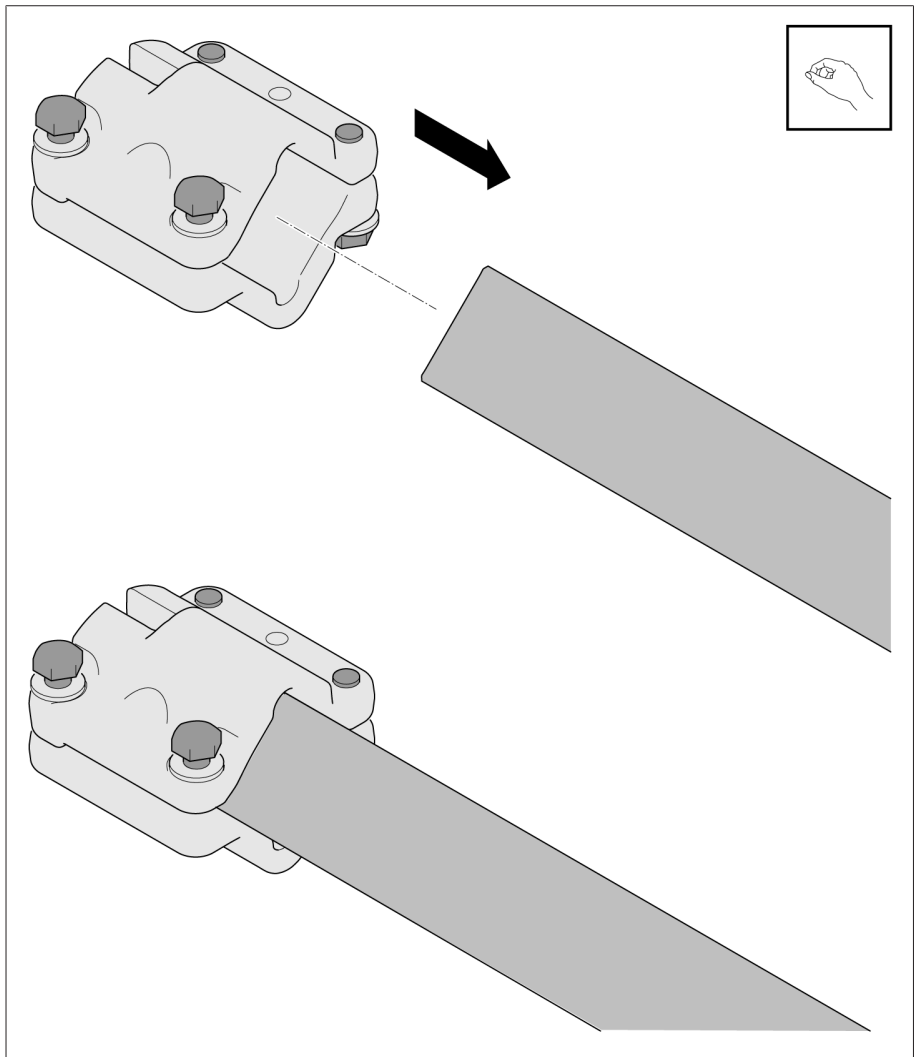

Figure 216: Slide coupling part onto square tube

6. Insert coupling bolt into shaft end of drive. Grease coupling part, coupling bolt and shaft end (e.g. ISOFLEX TOPAS L32). Slide square tube with coupling part onto shaft end.

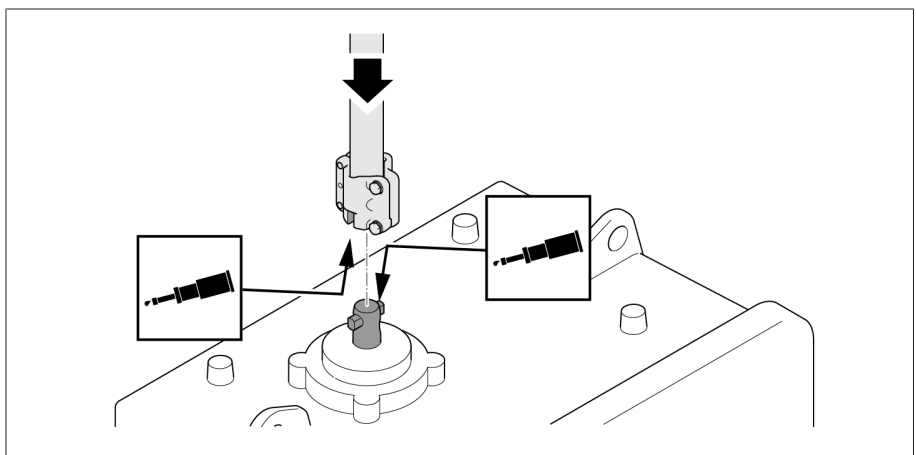

Figure 217: Sliding square tube with coupling part onto shaft end

7. Attach square tube to drive.

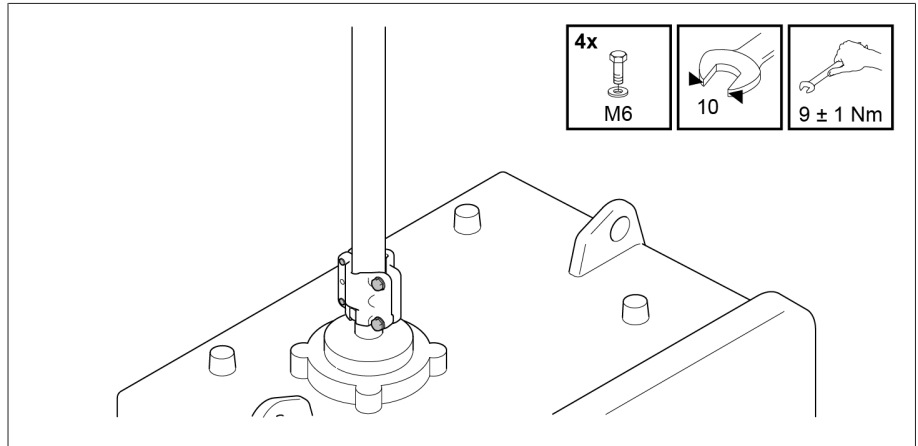

Figure 218: Attaching square tube to drive

8. Pivot square tube away from axis.

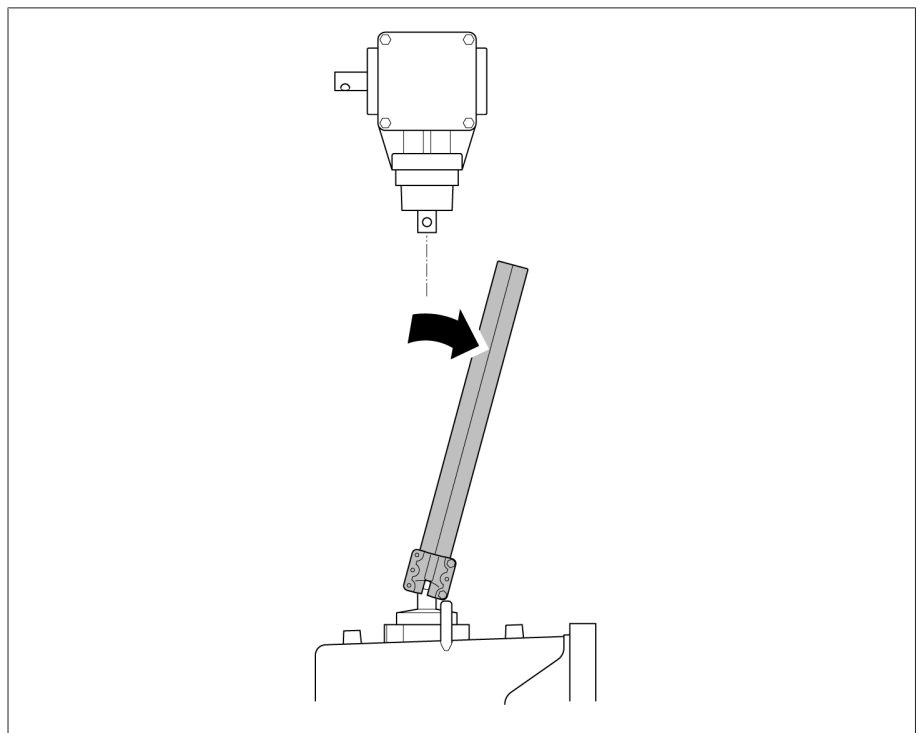

Figure 219: Pivoting square tube away from axis

9. When installing inner tube of telescopic protective tube, shorten on the side without slots if necessary. The minimum dimension for overlapping the two protective tubes is 100 mm.



Inner tube must not be deformed and must be deburred in order to slide easily in the outer tube.

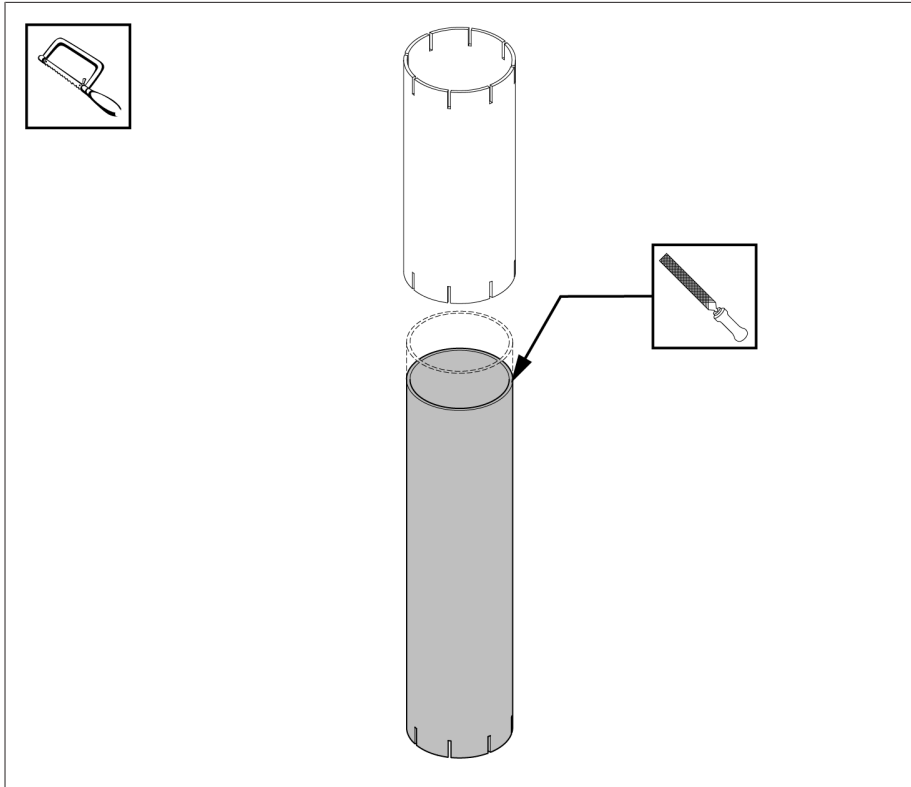

Figure 220: Deburring inner tube

Dimension A (= distance between shaft end of drive and shaft end of bevel gear)	Inner tube	Outer tube
170 mm...190 mm	Shorten to 200 mm	= 200 mm
191 mm...1,130 mm	Dimension A + 20 mm	= 200 mm
1,131 mm...1,598 mm	= 700 mm	= 1,150 mm
1,599 mm...2,009 mm	= 1,150 mm	= 1,150 mm

- Slide outer tube over inner tube. When doing so, make sure that the non-slotted side of the inner tube is facing upwards. Slide telescopic protective tube onto square tube. Then slide hose clips over telescopic protective tube.

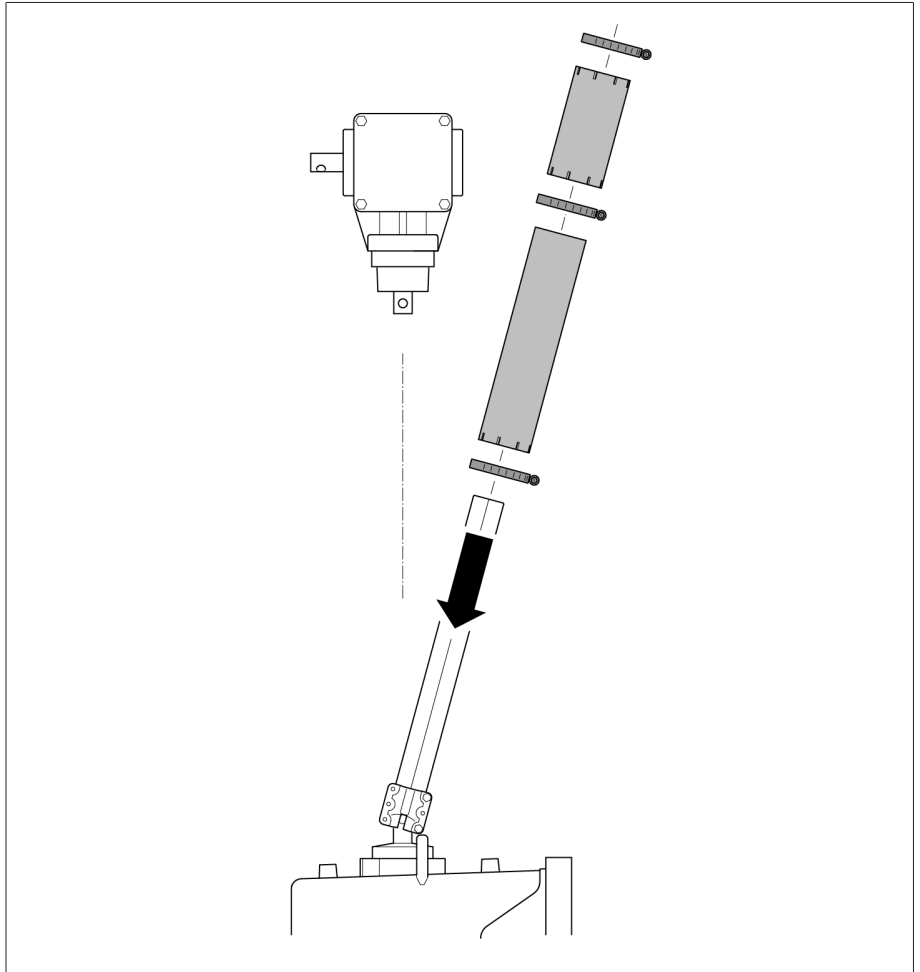

Figure 221: Sliding on telescopic protective tube

- Place adapter ring over bearing collar of bevel gear and slide upwards. Insert coupling bolt into shaft end of bevel gear. Pivot square tube back to axis.

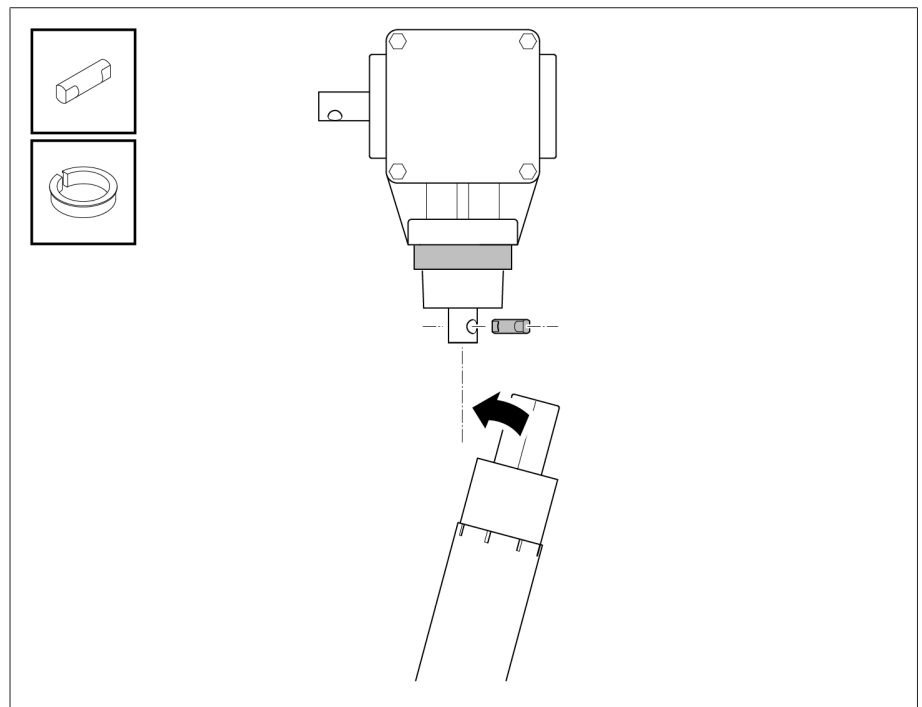

Figure 222: Fitting adapter ring and coupling bolt

- Grease coupling brackets, coupling bolt and shaft end (e.g. ISOFLEX TOPAS L32) and secure square tube with coupling brackets on the bevel gear. Set a unilateral axial clearance of 3 mm between the coupling bolt and upper coupling piece.

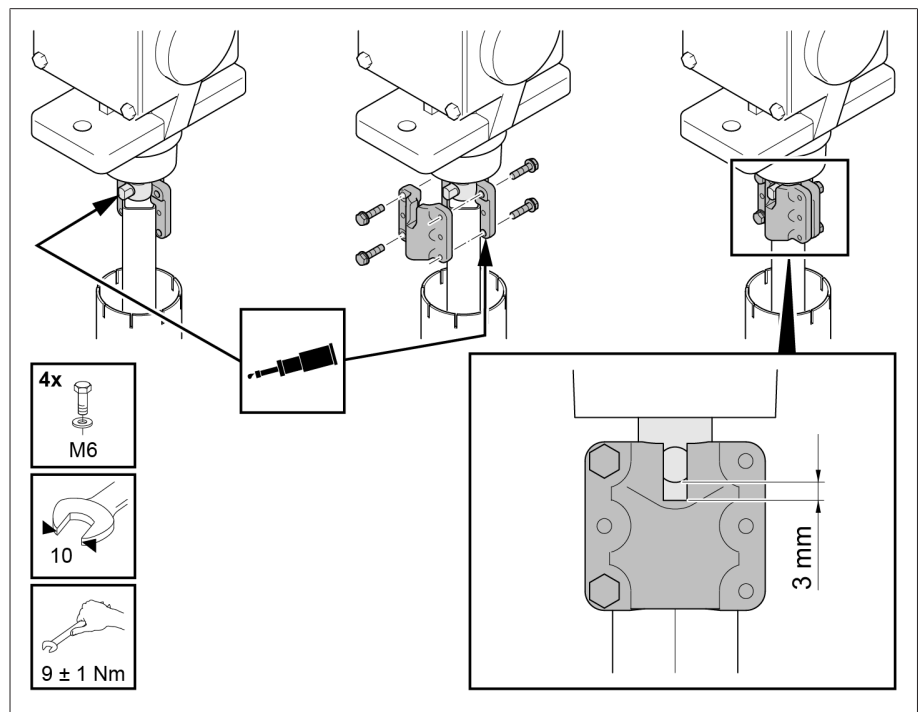

Figure 223: Mounting coupling brackets

- Attach bottom protective tube (inner tube) with a hose clip to bearing collar of drive **1**. Then slide upper protective tube (outer tube) over adapter ring on bevel gear **2**. Secure upper protective tube to bottom protective tube with hose clip both at top end and at the connection point **3**.

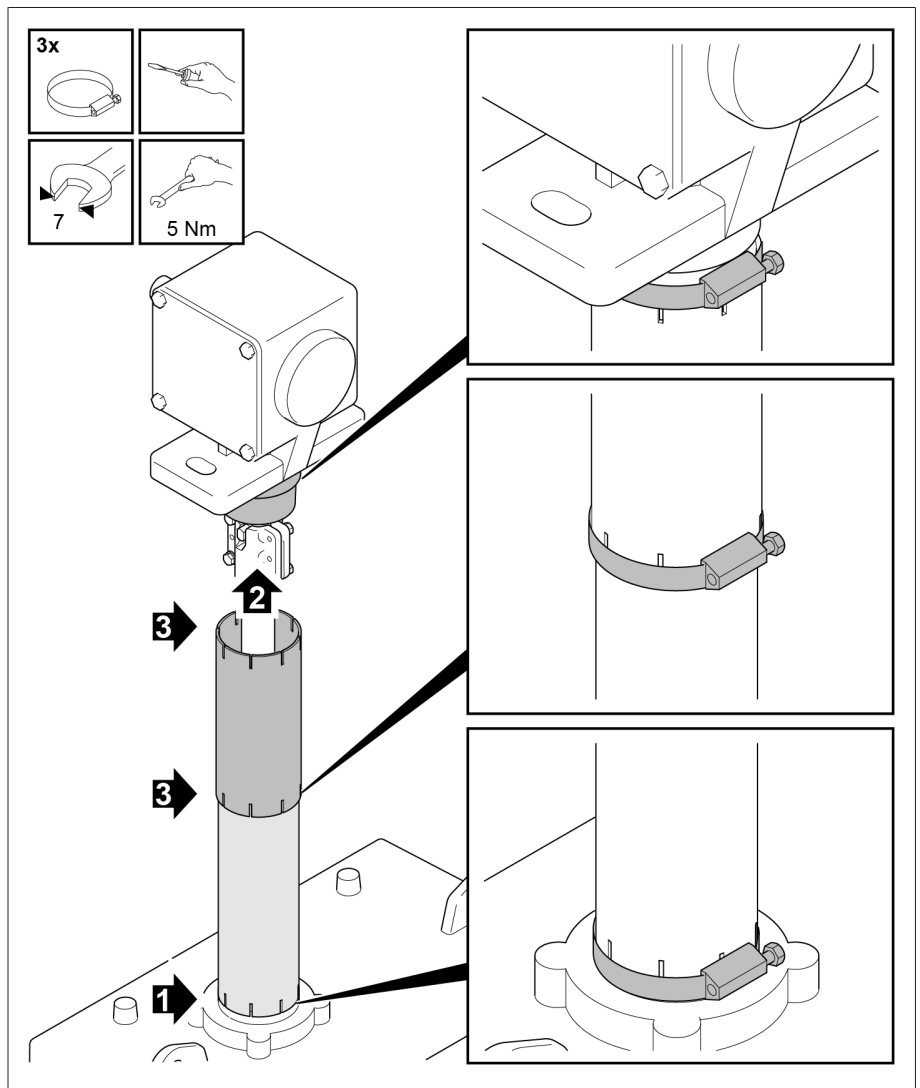

Figure 224: Mounting protective tube

5.4.6.2 Fitting a horizontal drive shaft without cardan joints

Permitted axial displacement

Minor axial displacements of the horizontal drive shaft are permitted as long as they do not exceed 35 mm per 1000 mm of square tube length (this corresponds to 2°).

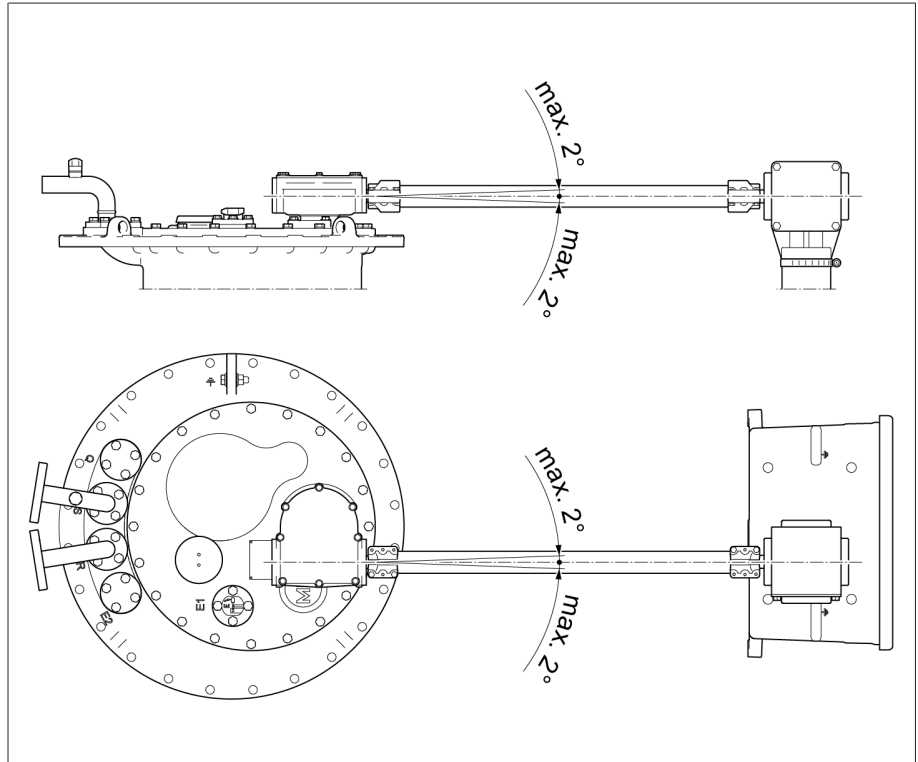

Figure 225: Permitted maximum axial displacement of horizontal drive shaft without cardan joint

Aligning upper gear unit on the on-load tap-changer head

In order to correctly install the horizontal drive shaft, under certain circumstances you may have to first align the upper gear unit so that the upper gear unit is flush with the bevel gear. With a multi-column on-load tap-changer model, it may also be necessary to align the upper gear units in the individual on-load tap-changer columns with each other in order to couple the on-load tap-changer columns together.

To do so, proceed as follows:

1. **NOTICE!** Damage to the on-load tap-changer due to alignment of the gear unit when the oil compartment is not completely full. Ensure that the oil compartment is filled completely with insulating fluid.
2. Loosen screws and turn pressure ring segments to one side.

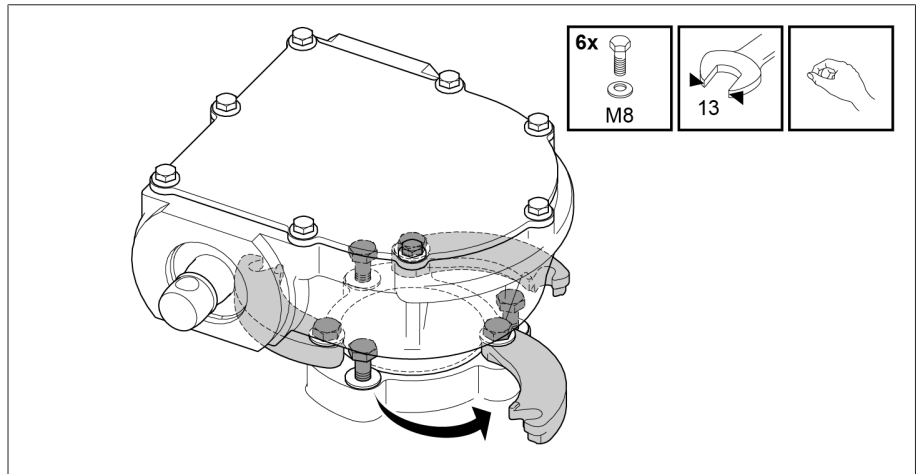

Figure 226: Pressure ring segments

3. **NOTICE!** Damage to the on-load tap-changer due to incorrect alignment of the upper gear unit. Align the gear unit so that the horizontal drive shaft is flush with the drive shaft of the gear unit. While aligning the gear unit, turn the unit's drive shaft so that its output shaft retains its original position.

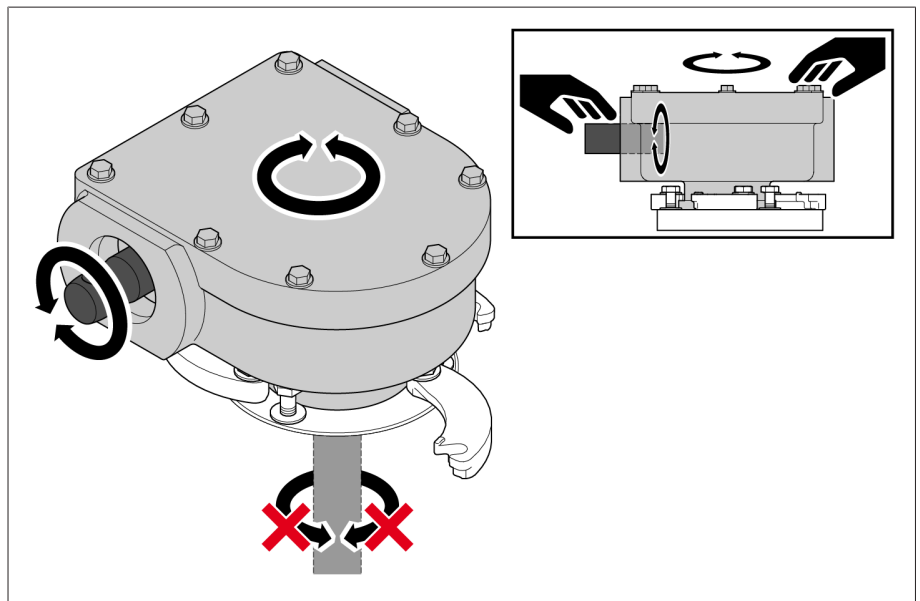

Figure 227: Aligning the gear unit

- Swivel pressure ring segments back towards the gear unit and tighten the screws. Ensure that the locking washer is between the screw head and the pressure ring segment and that the pressure ring segments are firmly in contact with the gear unit housing.

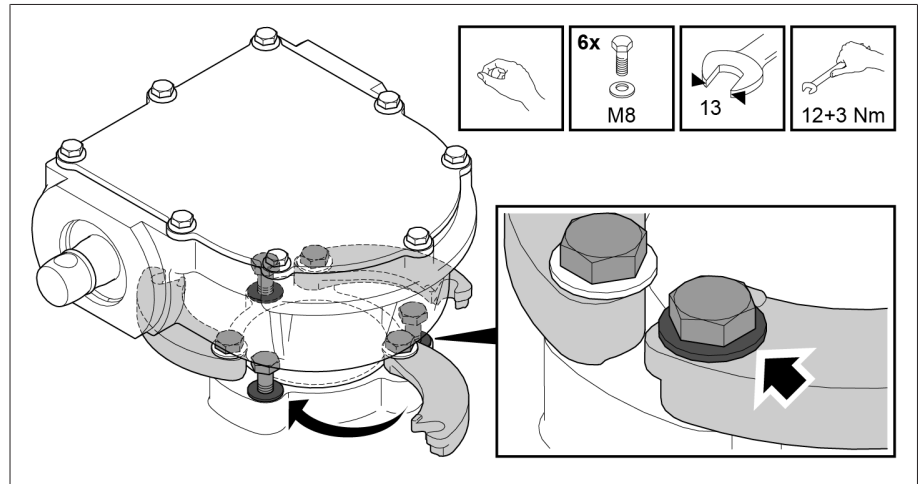

Figure 228: Securing the pressure ring segments

Fitting horizontal drive shaft



You can turn the temperature sensor if this is necessary for fitting the drive shaft.

To fit the horizontal drive shaft, proceed as follows.

- Calculate dimension A between the shaft end of the upper gear unit and the shaft end of the bevel gear and shorten the square tube to length $A - 9$ mm.

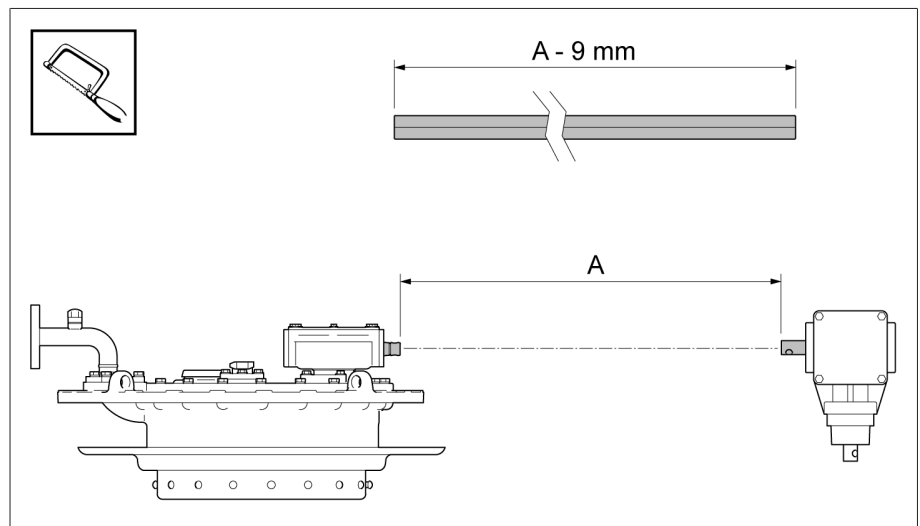

Figure 229: Shortening the square tube

2. Calculate inside width B between the housings of the upper gear unit and the bevel gear. Cut down the protective cover to $B - 2$ mm and deburr the cut edges. Protect the protective cover against corrosion with a coat of paint.

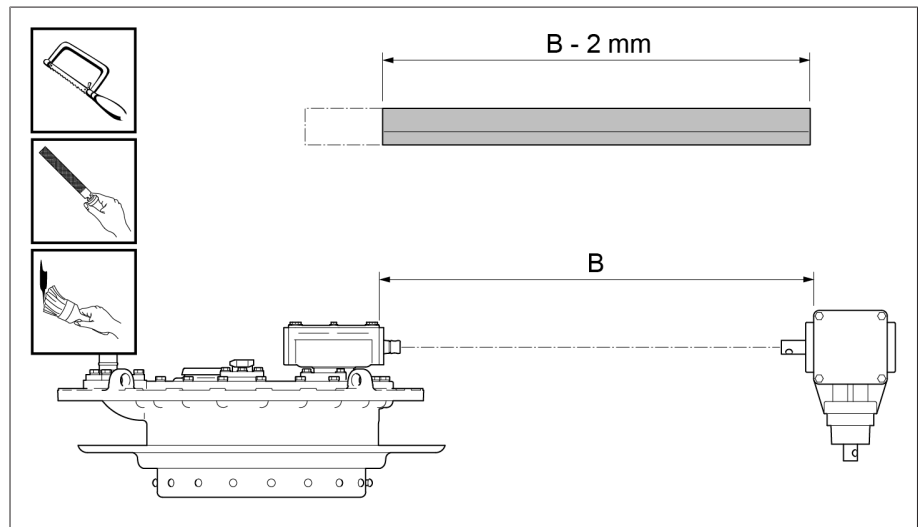

Figure 230: Shortening, deburring, and coating protective cover

3. Slide the loosely screwed-together coupling part onto the square tube until the stop is reached.

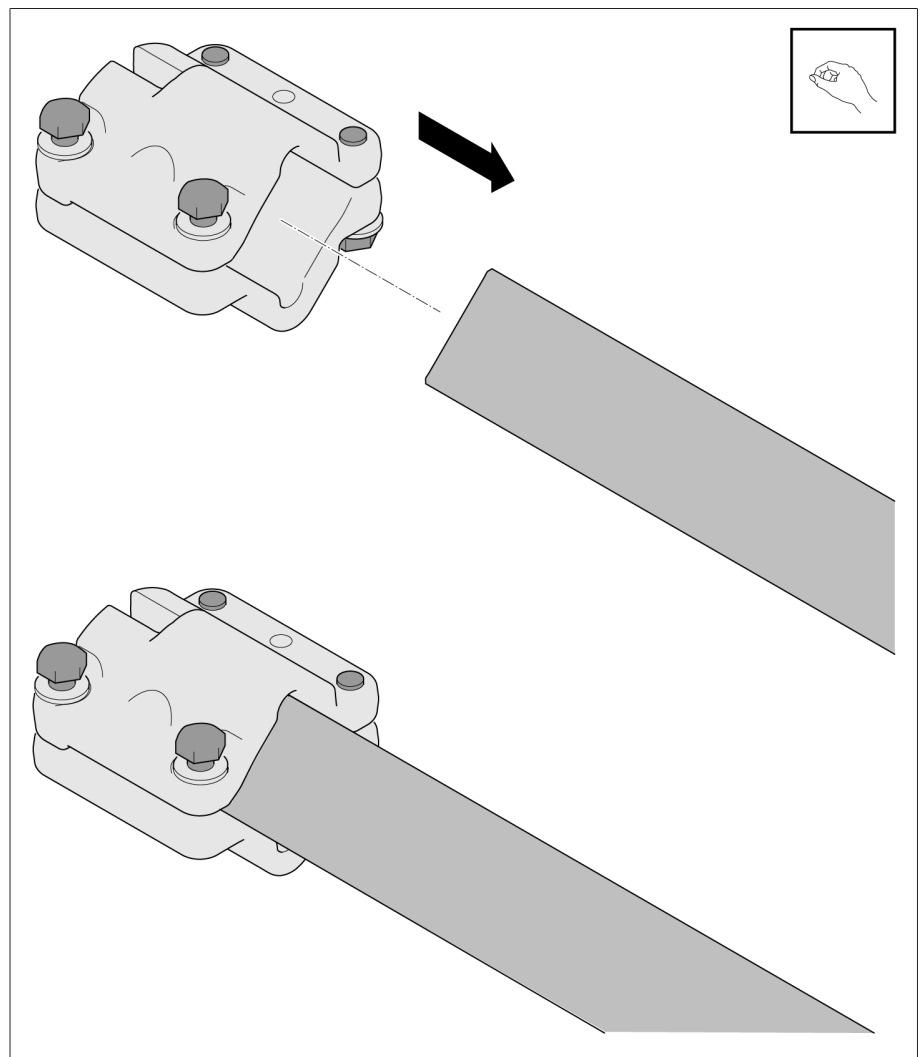

Figure 231: Sliding coupling part onto square tube

4. Grease the coupling bolt, coupling part and shaft end of the bevel gear (e.g. ISOFLEX TOPAS L32) and insert the coupling bolt into shaft end. Thread the hose clip onto the square tube and slide the square tube with the coupling part onto the shaft end.

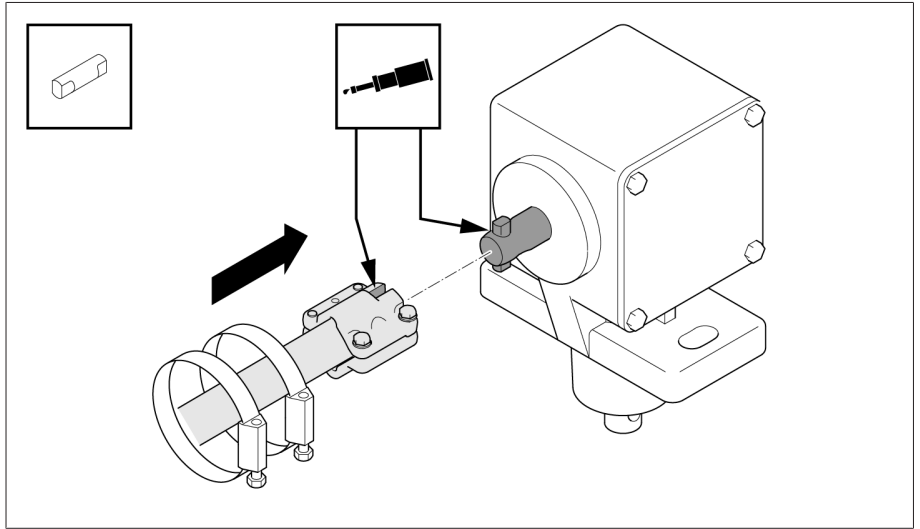

Figure 232: Sliding the square tube with the coupling part onto the shaft end

5. Secure square tube on bevel gear.

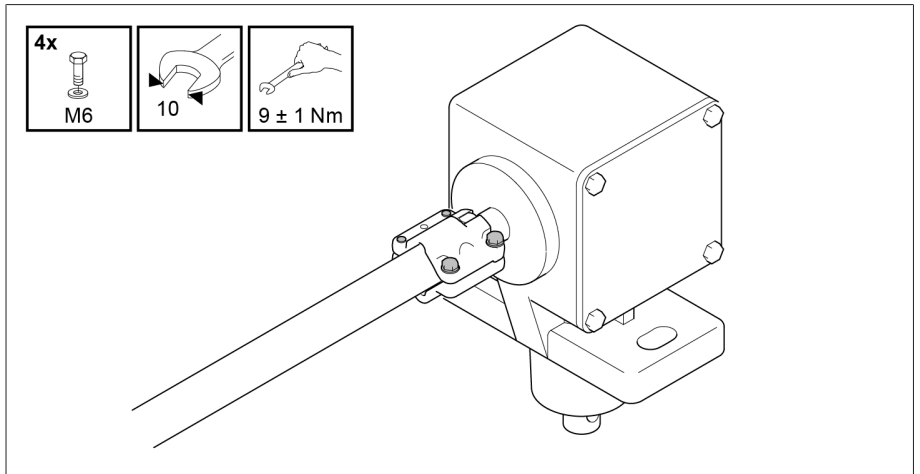

Figure 233: Securing the square tube on the bevel gear

6. Grease the coupling bolt, the coupling brackets and the shaft end of the upper gear unit (e.g. ISOFLEX TOPAS L32) and insert the coupling bolt into the shaft end. Secure the square tube with the coupling brackets on the upper gear unit.

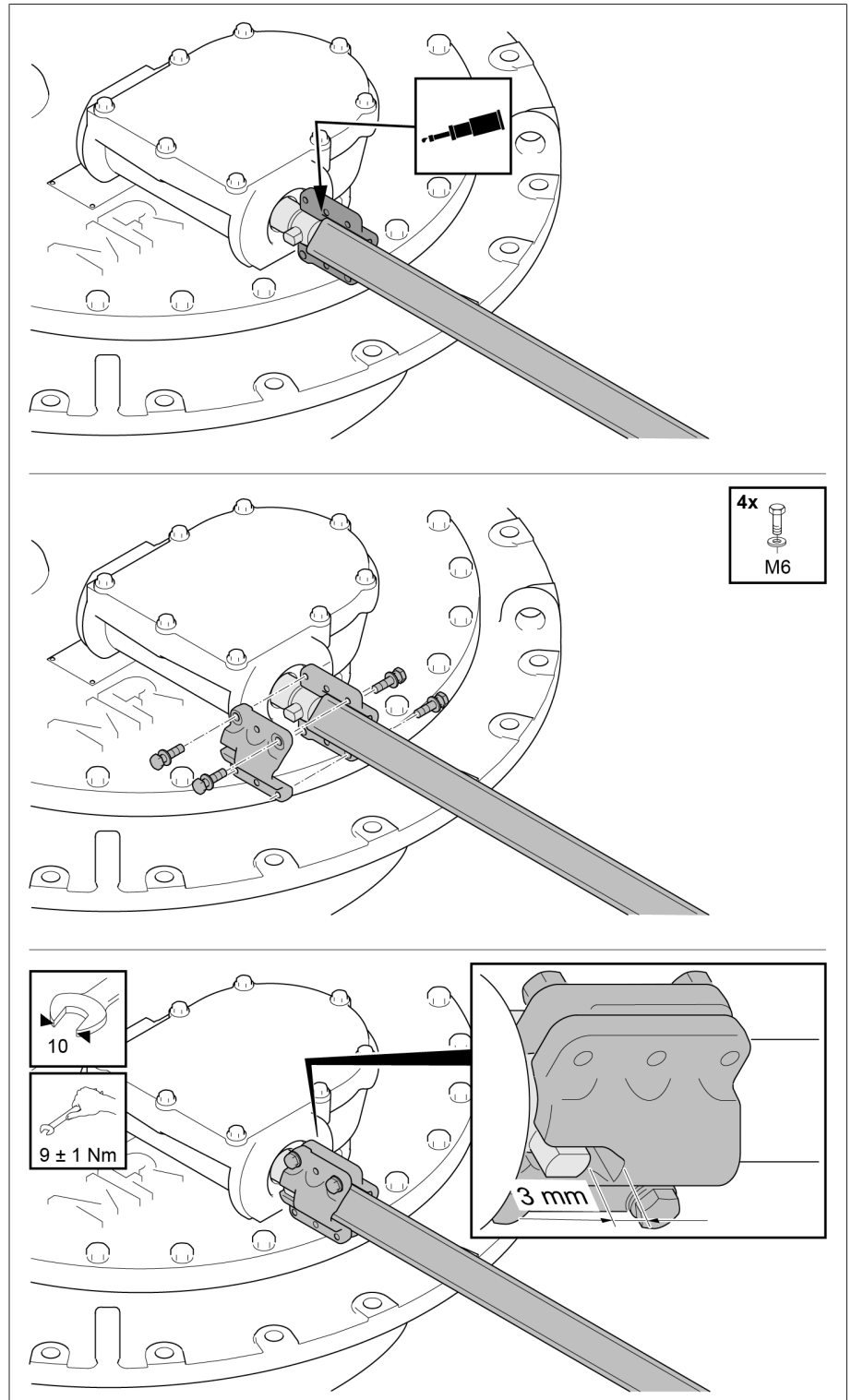

Figure 234: Secure the square tube on the upper gear unit.

- Attach the shortened protective cover to the housing lugs on the on-load tap-changer head and the bevel gear. Secure each end of the protective cover with a hose clip.

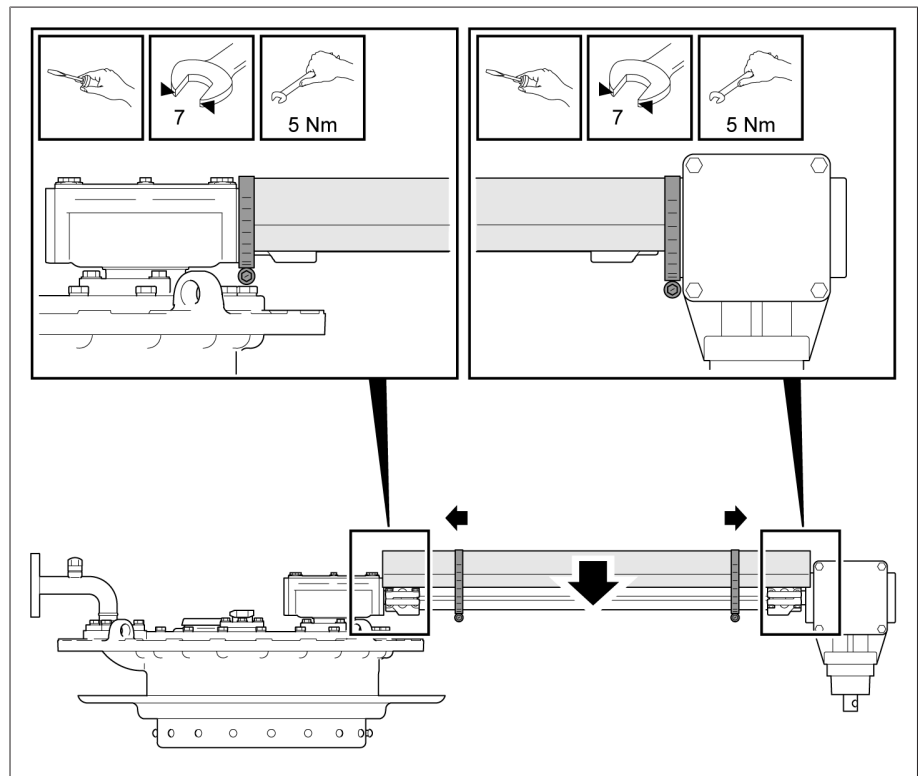

Figure 235: Fitting the protective cover

- If using a bearing block or angle gear, attach caps to the protective cover. Before attaching the caps, drill 3 holes on the shortened side of the protective cover and 2 holes on the un-shortened side (each with $\text{Ø } 3.5 \text{ mm}$) using a hand drill with drill bit

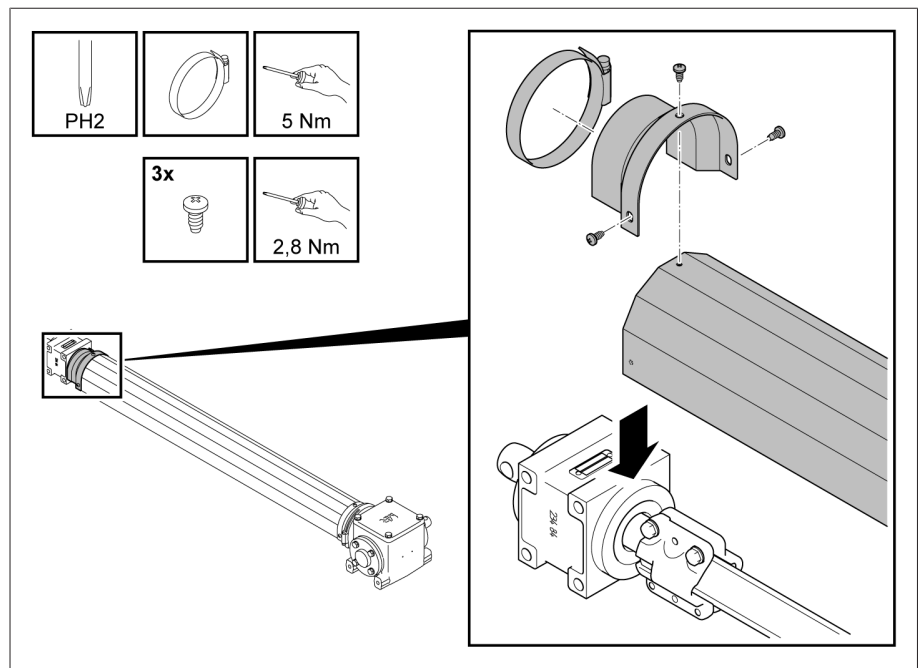

Figure 236: Bearing block caps

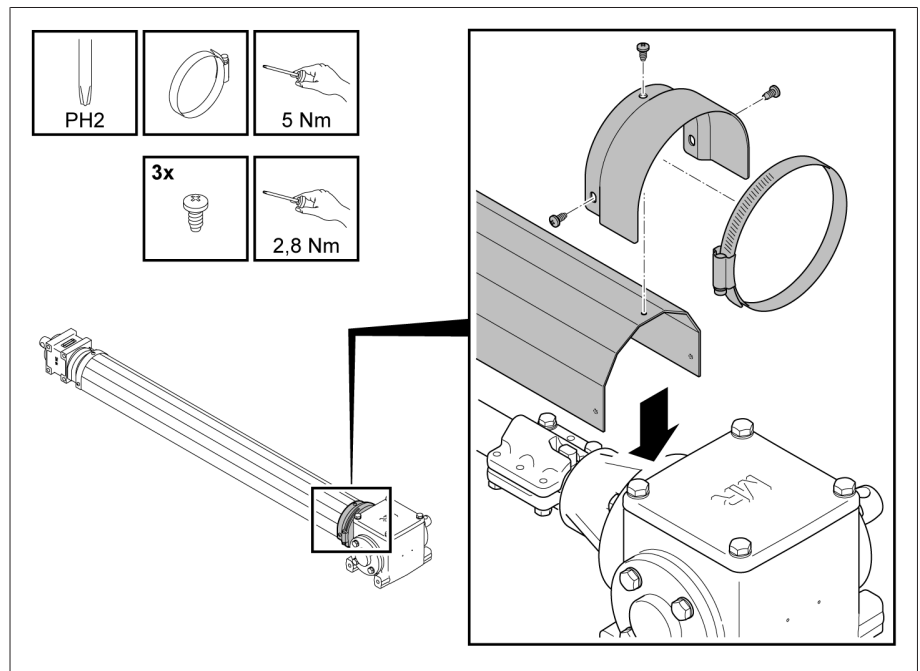

Figure 237: Angle gear caps

5.4.6.2.1 On-load tap-changer sets and combinations

For two-column and three-column on-load tap-changer models, the individual on-load tap-changer columns can be driven by a common motor-drive unit or several motor-drive units.

Regardless of the number of on-load tap-changer columns and motor-drive units, all on-load tap-changer columns and motor-drive units must be in the same operating position and must switch simultaneously (does not apply for ABC switching sequence).

To make sure that the on-load tap-changer columns that are driven by a common motor-drive unit switch simultaneously, you must couple these on-load tap-changer columns with horizontal drive shafts via the transformer cover. The offset between these on-load tap-changer columns during switching may be a maximum of 1 tap-change indicator section.

To couple the on-load tap-changer columns, proceed as follows:

Aligning upper gear unit on the on-load tap-changer head

In order to correctly install the horizontal drive shaft, under certain circumstances you may have to first align the upper gear unit so that the upper gear unit is flush with the bevel gear. With a multi-column on-load tap-changer model, it may also be necessary to align the upper gear units in the individual on-load tap-changer columns with each other in order to couple the on-load tap-changer columns together.

To do so, proceed as follows:

1. **NOTICE!** Damage to the on-load tap-changer due to alignment of the gear unit when the oil compartment is not completely full. Ensure that the oil compartment is filled completely with insulating fluid.
2. Loosen screws and turn pressure ring segments to one side.

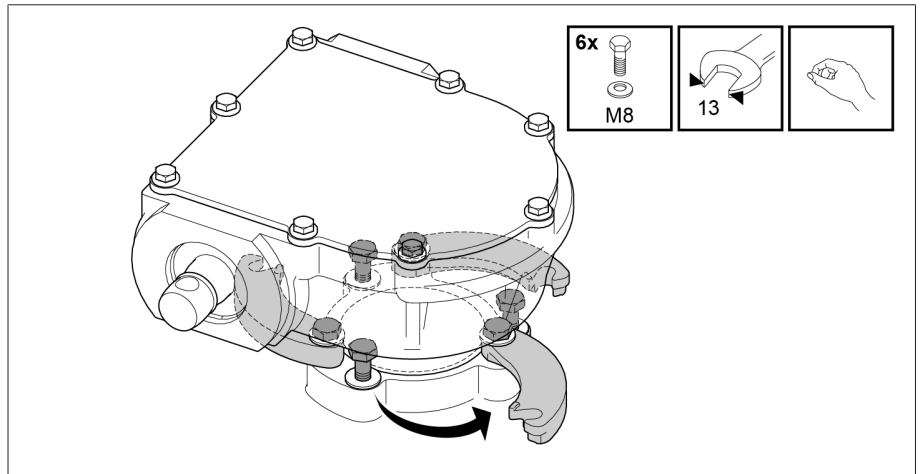

Figure 238: Pressure ring segments

3. **NOTICE!** Damage to the on-load tap-changer due to incorrect alignment of the upper gear unit. Align the gear unit so that the horizontal drive shaft is flush with the drive shaft of the gear unit. While aligning the gear unit, turn the unit's drive shaft so that its output shaft retains its original position.

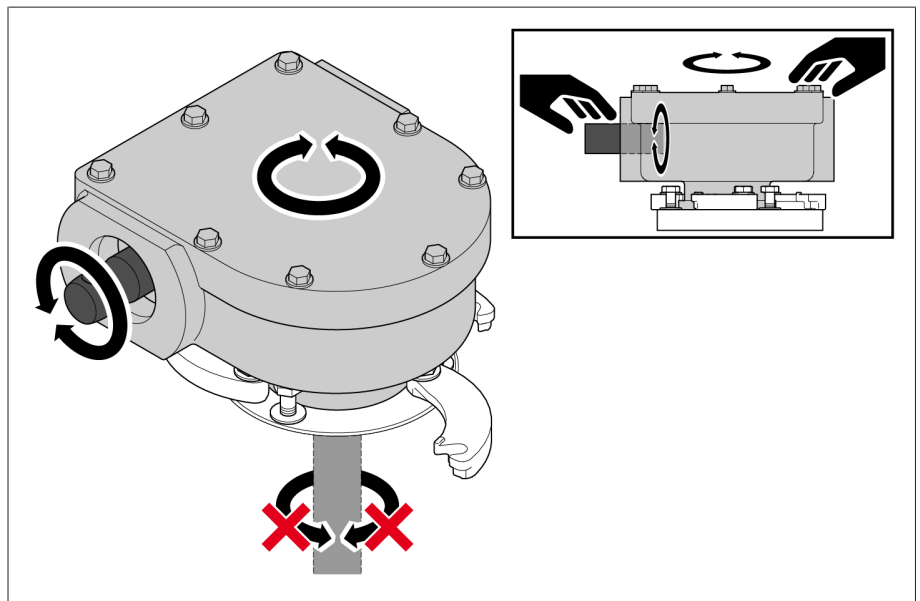

Figure 239: Aligning the gear unit

- Swivel pressure ring segments back towards the gear unit and tighten the screws. Ensure that the locking washer is between the screw head and the pressure ring segment and that the pressure ring segments are firmly in contact with the gear unit housing.

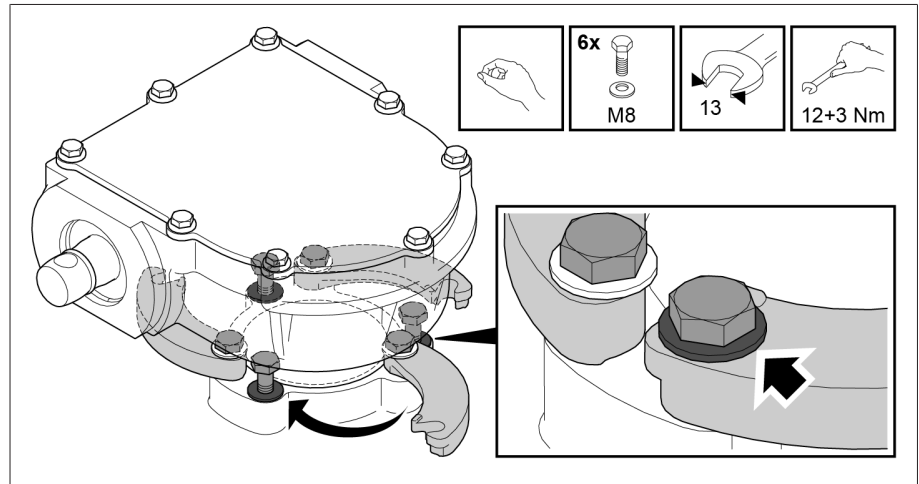

Figure 240: Securing the pressure ring segments

Coupling the on-load tap-changer columns together

- Ensure that all arrows on the drive shaft flange under the stamped serial number point in the same direction. The direction of the arrow indicates the direction of rotation when turning the hand crank of the motor-drive unit clockwise.
- Switch the on-load tap-changer columns one after another to the next operating position. To do so, turn the shaft end on each gear unit counter-clockwise one after another until the on-load tap-changer column switches position.

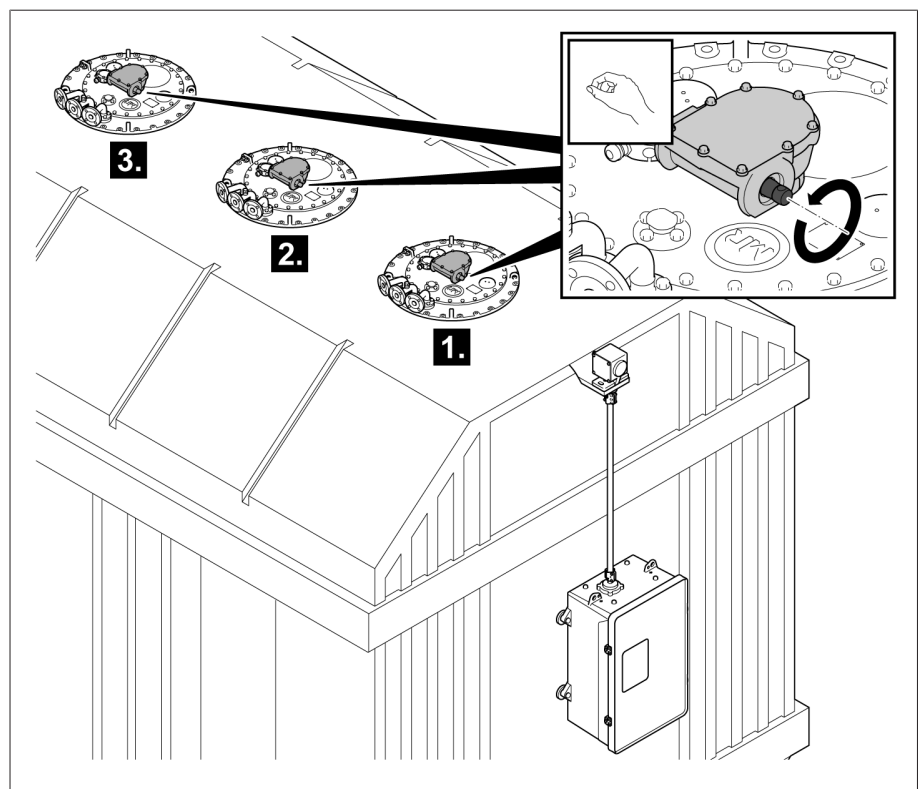

Figure 241: Manually switching the on-load tap-changer columns

- Check that all on-load tap-changer columns are in the same position.

- Couple the on-load tap-changer columns together via horizontal drive shafts. When doing so, begin with the on-load tap-changer column that is closest to the motor-drive unit.

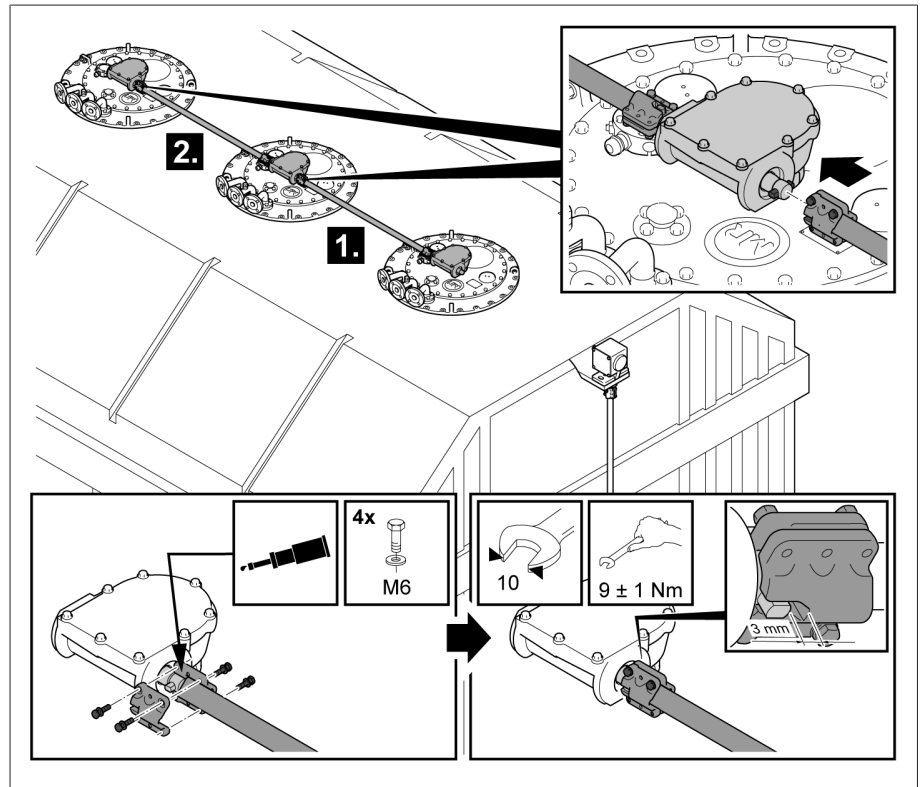

Figure 242: Coupling the on-load tap-changer columns

- NOTICE!** Damage to the on-load tap-changer columns due to incomplete tap-change operation. After installing all drive shafts, crank the drive shaft of the gear unit through a further 2.5 revolutions counter-clockwise to complete the tap-change operation fully.

- Switch the on-load tap-changer columns to the adjustment position by turning the drive shaft on the gear unit clockwise. Once the adjustment position has been reached and the on-load tap-changer columns have been switched, crank the drive shaft of the upper gear unit through another 2.5 revolutions clockwise to correctly complete the tap-change operation.

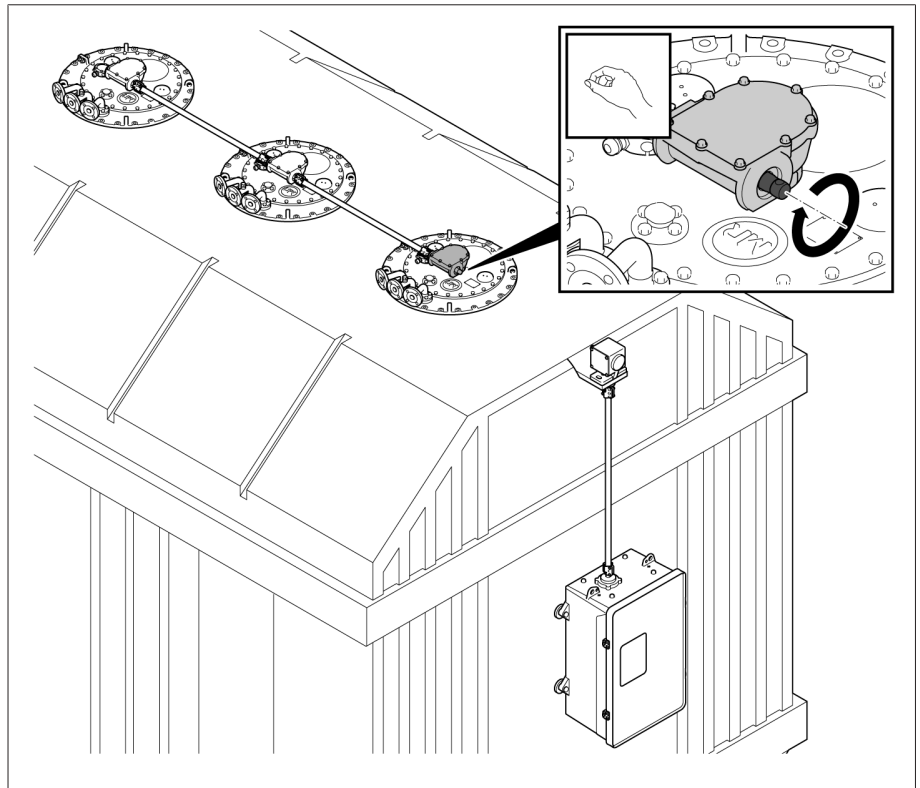

Figure 243: Switching the on-load tap-changer columns to the adjustment position

- Ensure that all on-load tap-changer columns switch simultaneously. Here, a minimal offset of max. 0.25 revolutions on the drive shaft of the gear unit is permitted.
- Check that all on-load tap-changer columns are in the same position.

9. Install the drive shaft between the bevel gear and the gear unit.

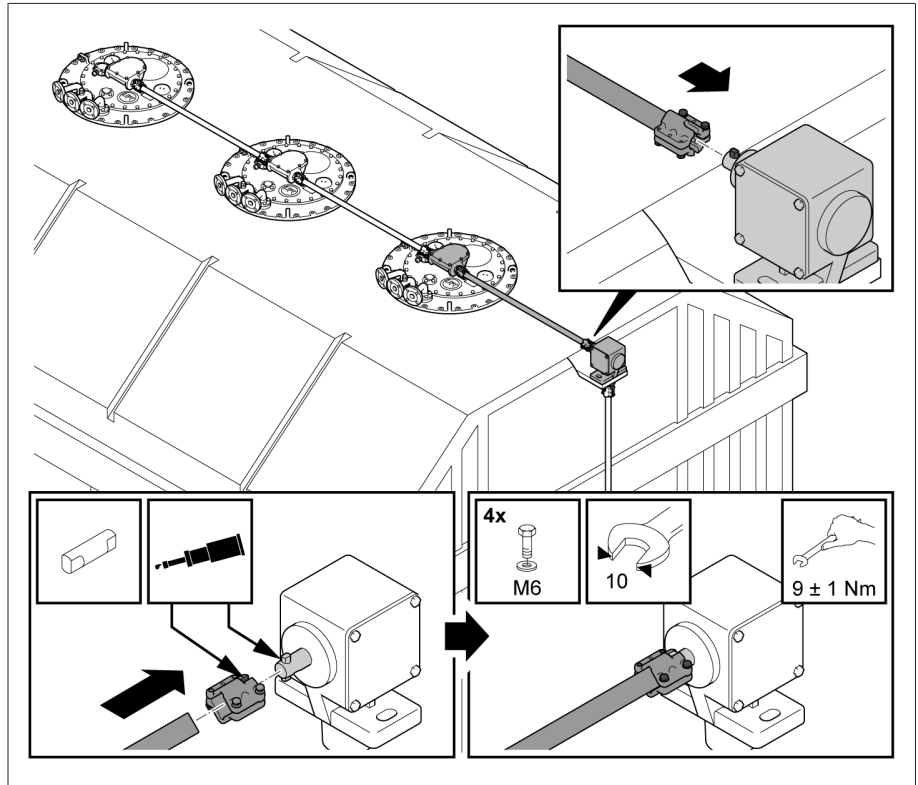

Figure 244: Installing the drive shaft between the bevel gear and the gear unit

5.4.6.3 Fitting drive shaft with cardan joints

Installation of the drive shaft with cardan joints is mainly designed as a vertical drive shaft between motor-drive unit and bevel gear.

Technically, a horizontal design is also possible. However, if using a horizontal design, please note that the protective cover supplied must be adapted accordingly and a cardan joint with an inner hub diameter of 25 mm must be used if you want to use the cardan joint on the upper gear unit.

Permitted axial displacements

An axial displacement of 20° is permitted for the vertical and horizontal drive shaft with cardan joints.

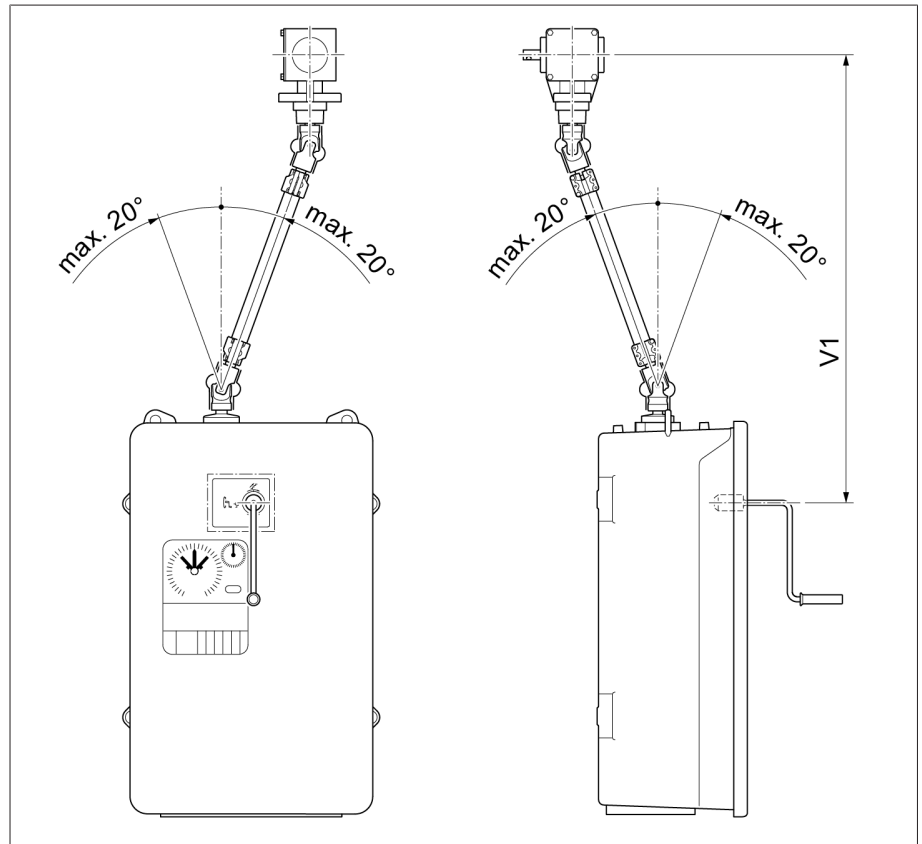

Figure 245: Permitted maximum axial displacement of vertical drive shaft with cardan joints

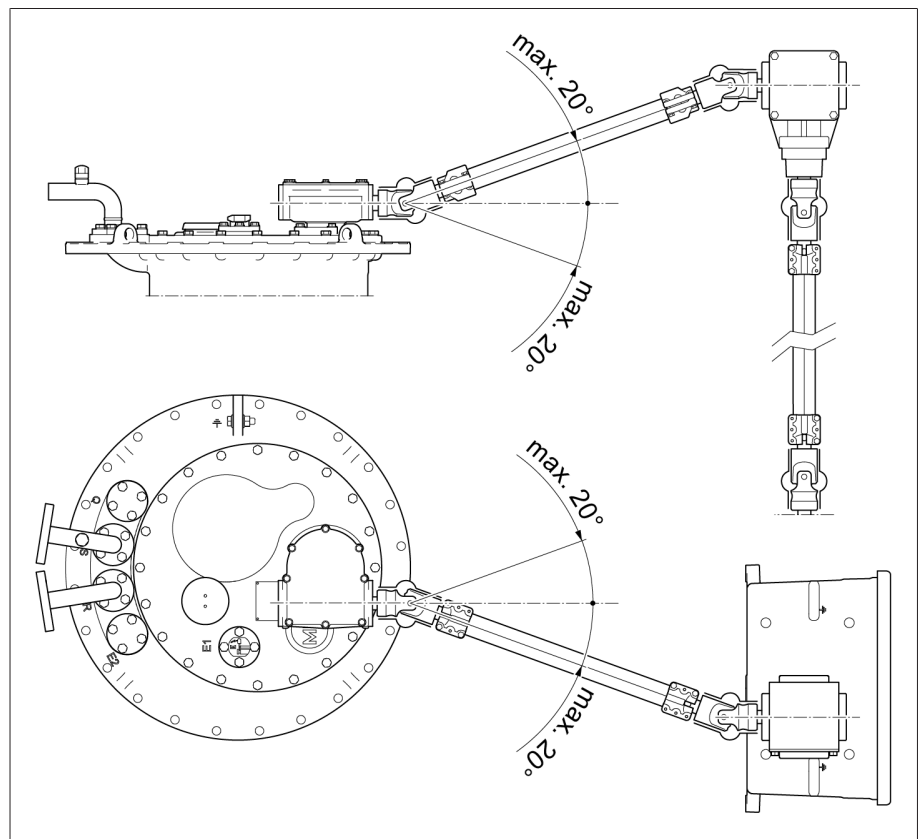

Figure 246: Permitted maximum axial displacement of horizontal drive shaft with cardan joints

NOTICE

Damage to property!

Improper mounting of the cardan joint may result in damage or malfunctions.

- > Ensure that the folding cardan joint does not damage the expansion bellows during mounting.
- > Ensure that the angle of deflection α is no greater than 20° .
- > Ensure that the angle of deflection α is the same on both cardan joints.

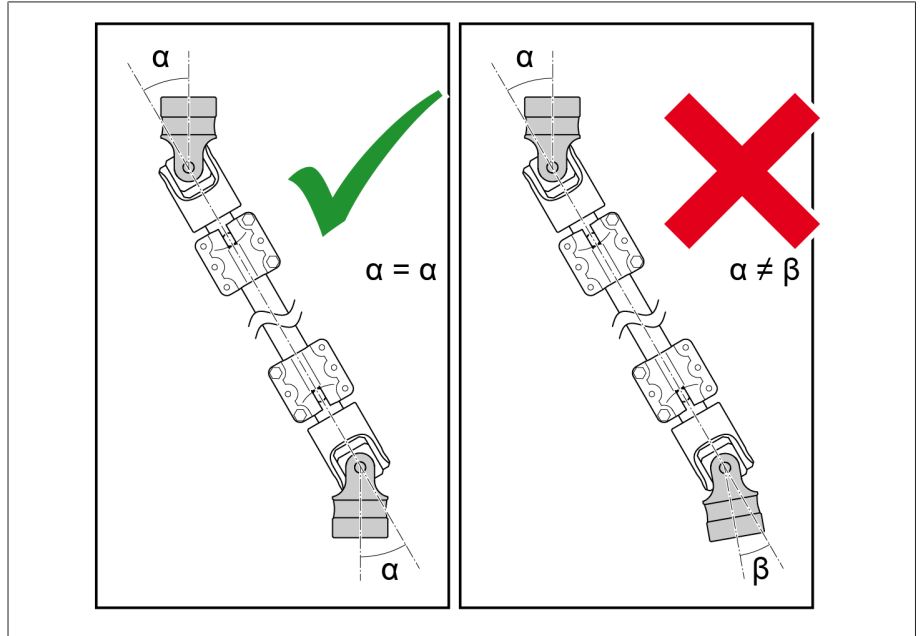

Figure 247: Angle of deflection α

To fit the drive shaft with cardan joints, proceed as follows:

1. Grease coupling bolts, coupling brackets, and shaft ends, e.g. ISOFLEX TOPAS L 32.

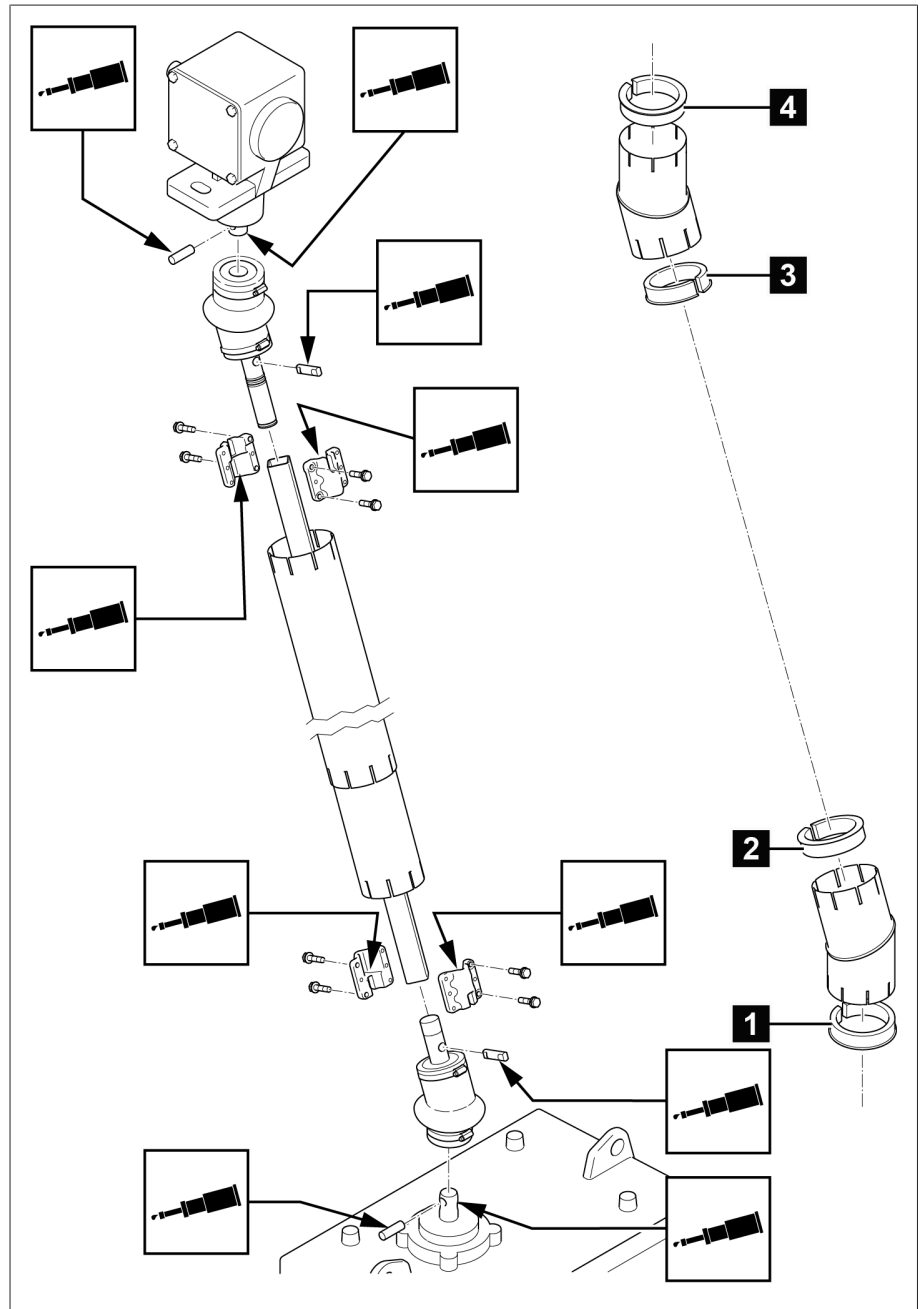

Figure 248: Greasing coupling bolts, coupling brackets, and shaft ends

Position	Name	Quantity
1 below on the ED	Adapter ring $\varnothing 82 \times 102$	1
2	Adapter ring $\varnothing 87 \times 102.5$	1
3	Adapter ring $\varnothing 94.5 \times 102.5$	1
4 above on the CD6400	Adapter ring $\varnothing 71 \times 102.5$	1

2. Insert adapter rings into the collar of the rotating protective tube **1**. Fit the two parts of pivotable protective tube together **2** and turn them towards one another **3** to set the corresponding angle.

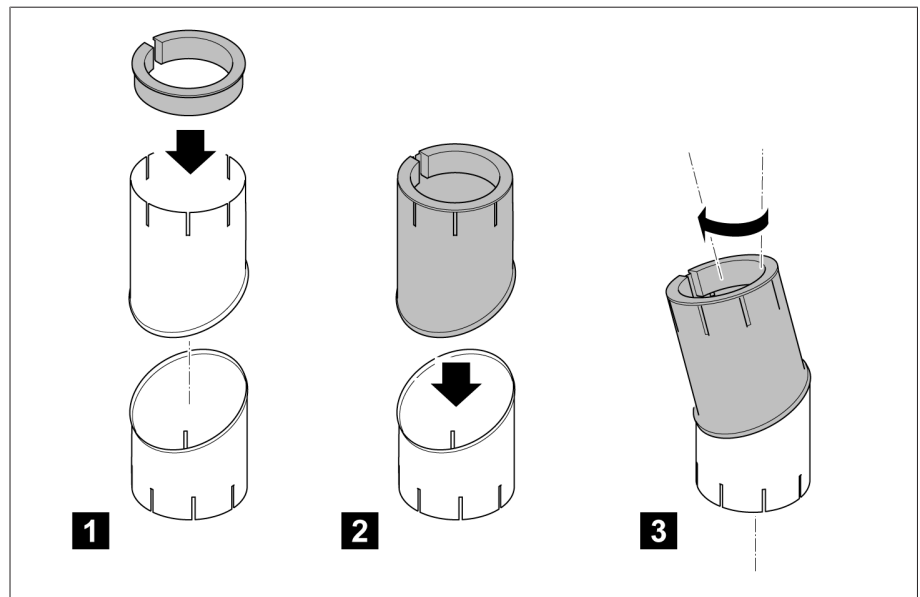

Figure 249: Inserting adapter in pivotable protective tubes

3. When supplied, the cardan joints are fitted with coupling bolts **1**. To mount on the shaft end, the following steps must be taken: Remove hose clip **2**. Slide up expansion bellows **3**. Remove coupling bolt **4**. Slide cardan joint over device's output shaft **5**. Push in coupling bolt **6**. Slide expansion bellows over this **7**. Secure expansion bellows with hose clip **8**.

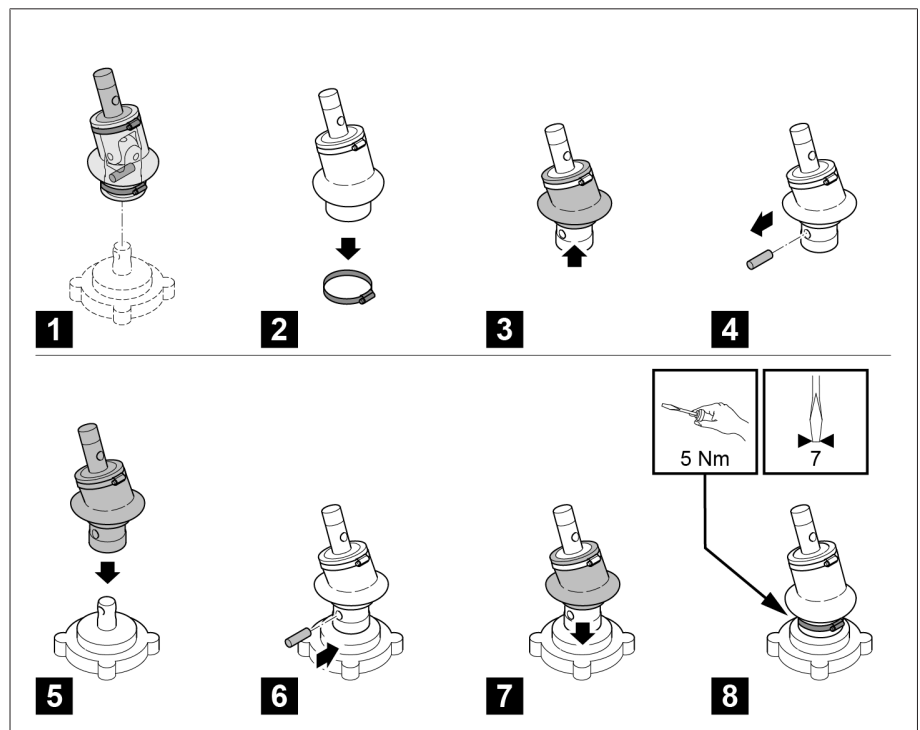

Figure 250: Mounting cardan joints

4. Connect shorter cardan joint supplied to shaft end of motor-drive unit with coupling bolt.

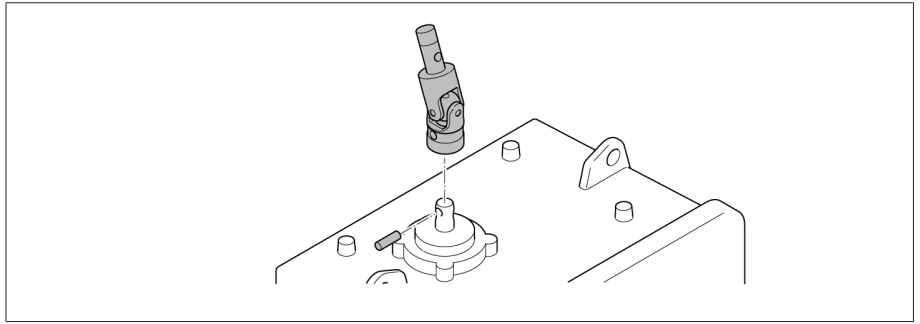

Figure 251: Attaching cardan joint on shaft end of motor-drive unit

5. **NOTICE!** Attach second, longer cardan joint to the bevel gear such that the position of both cardan joint lugs is the same on the bevel gear and motor-drive unit. If this is not done, damage or malfunctions may result.

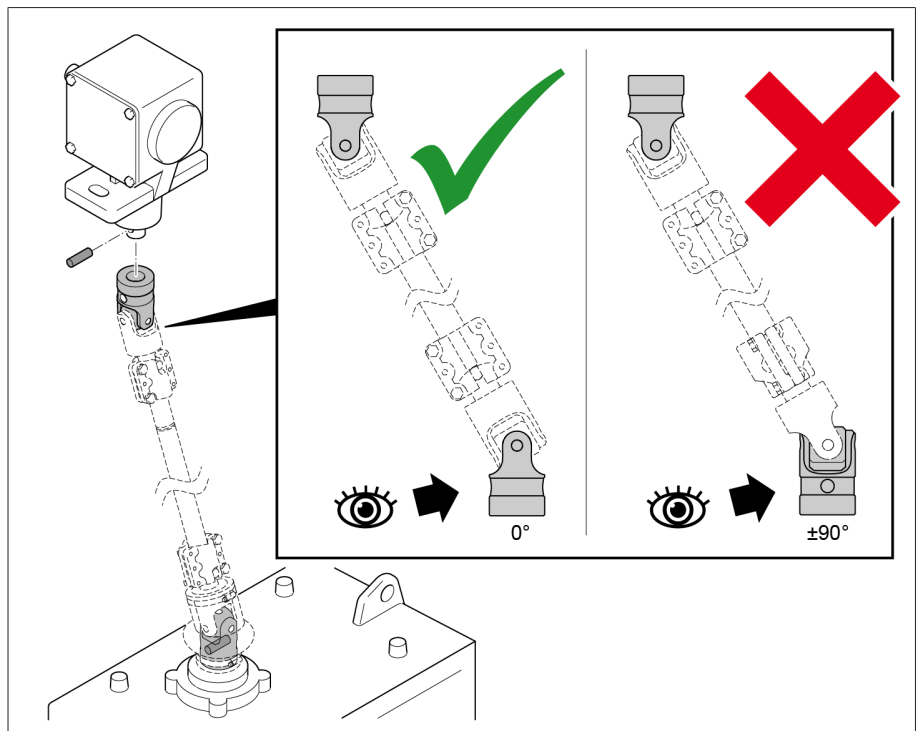

Figure 252: Fitting second cardan joint on bevel gear

6. Secure expansion bellows with hose clip.

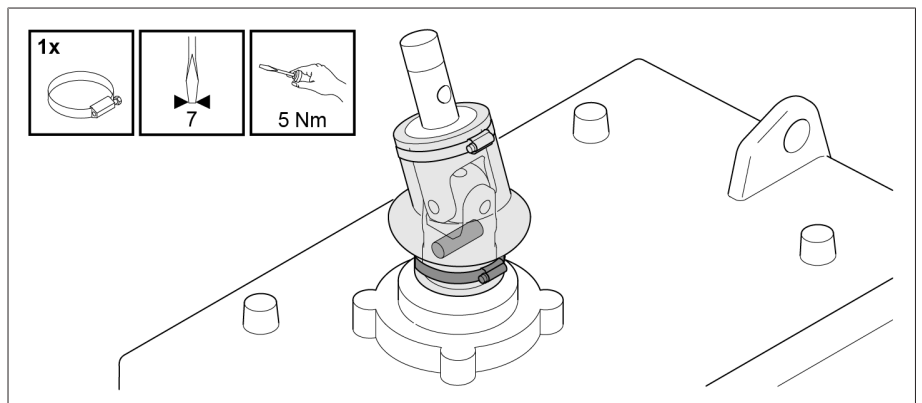

Figure 253: Securing expansion bellows with hose clip

7. Provisionally connect loose shaft ends of the joints to an angle bar and align so that they are in line.

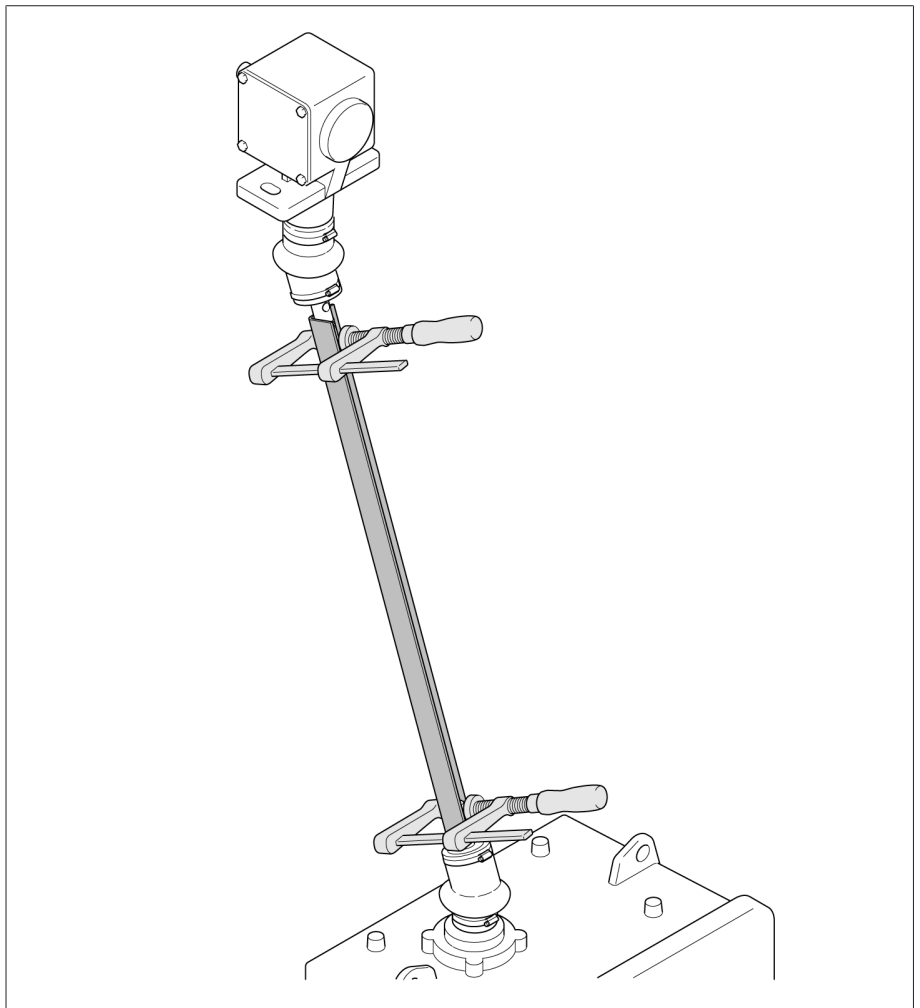

Figure 254: Connecting shaft ends with angle bar

8. Determine dimension A between the shaft ends. Cut square tube to $LR = A + 100$ mm (LR = length of square tube). Deburr cut surfaces of square tube.

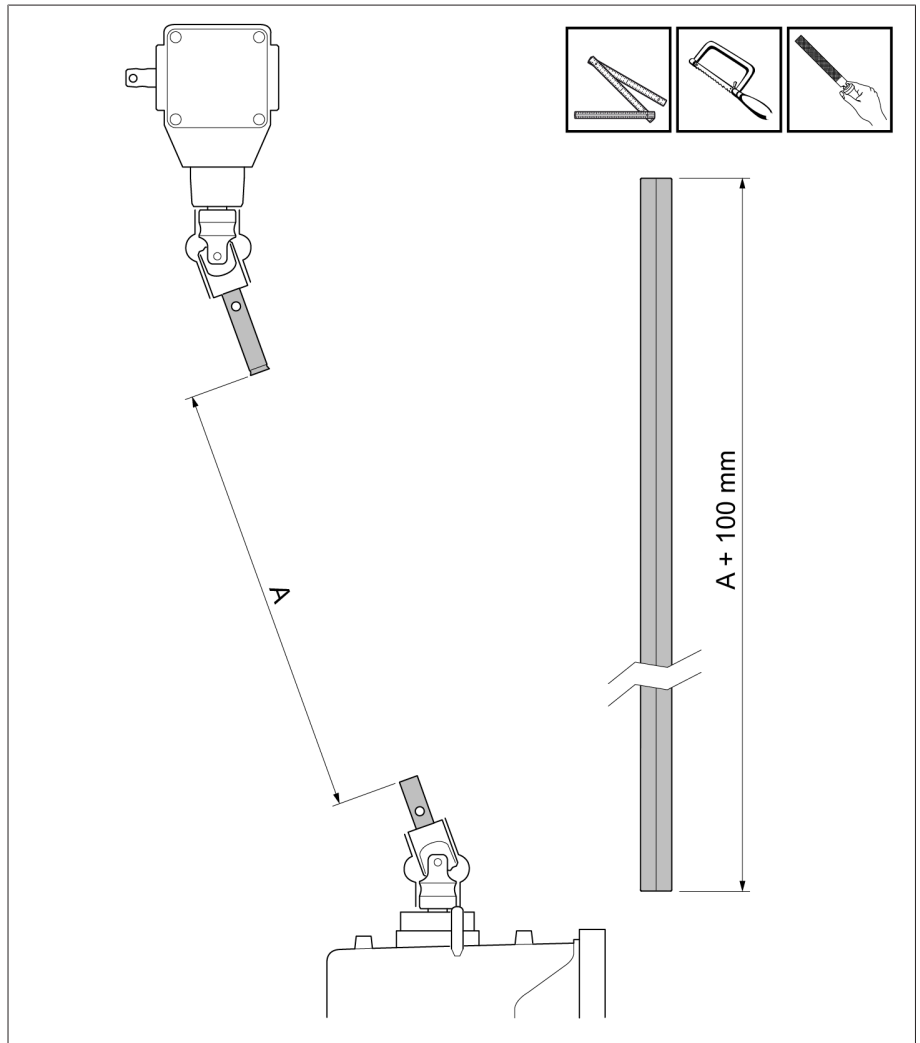

Figure 255: Shortening square tube

9. Before beginning installation, shorten both telescopic tubes to the corresponding dimension A (A = dimension between both cardan joint ends) and deburr.

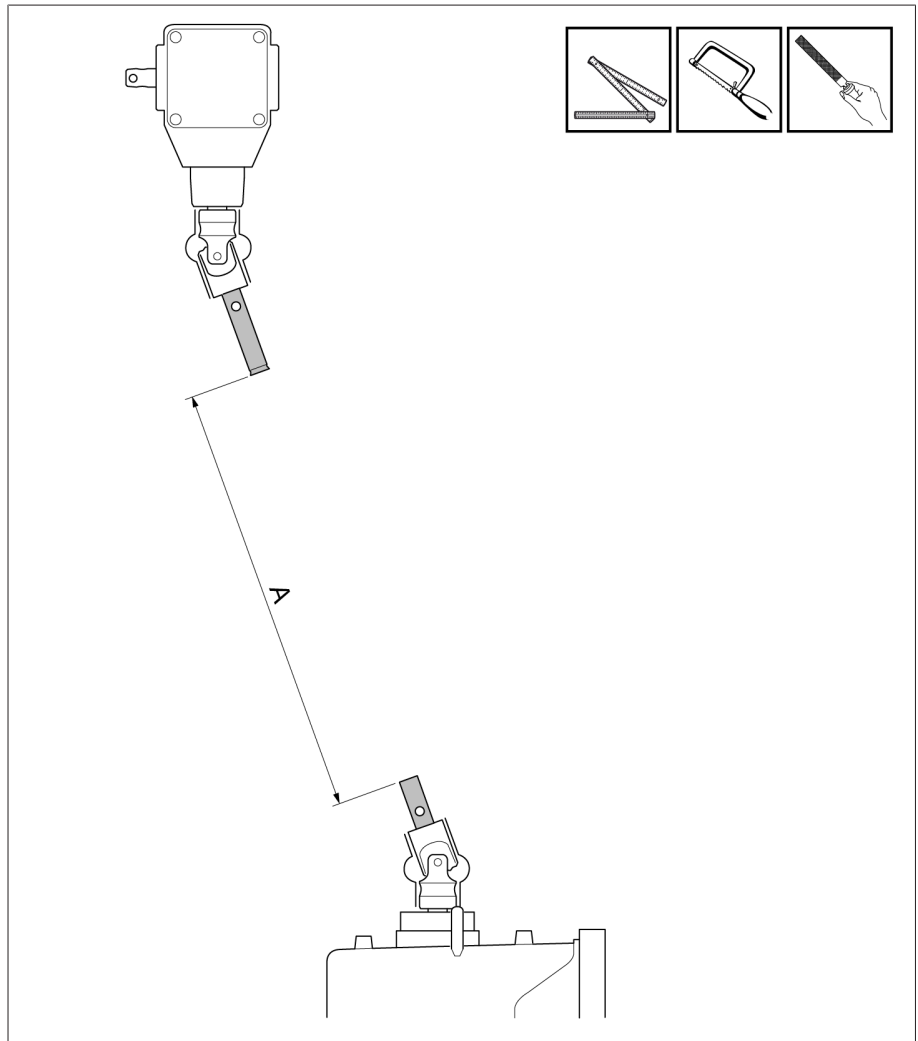

Figure 256: Shortening telescopic tubes

Dimension A (= distance between shaft ends of the drive and the bevel gear)	Inner tube	Outer tube
260 mm	Shorten to 200 mm	200 mm
261 mm...760 mm	Shorten to A-60 mm	200 mm
761 mm...1,090 mm	700 mm	Shorten to A-60 mm
1,091 mm...1,700 mm	700 mm	1,150 mm
1,701 mm...1,900 mm	1,150 mm	1,150 mm

10. Fit one adapter ring to bearing collar of motor-drive unit and fit other adapter ring to bearing collar of bevel gear.

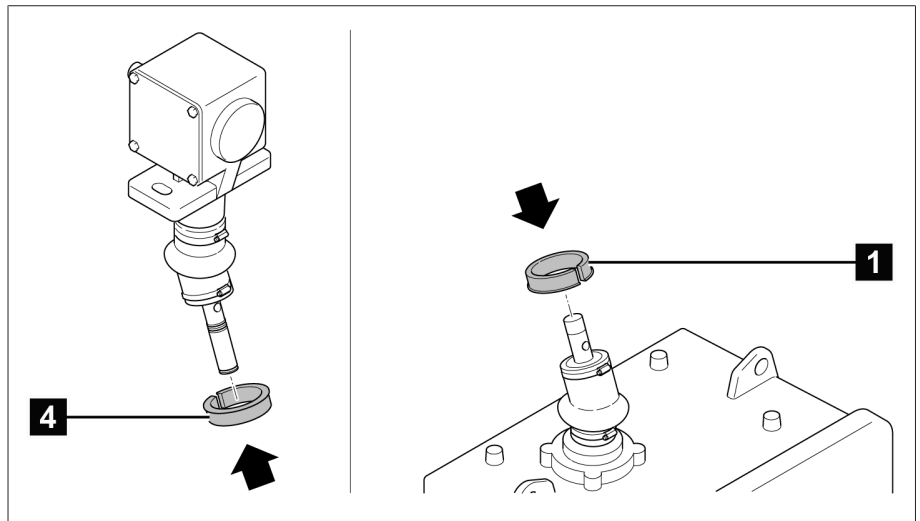

Figure 257: Fitting adapters

11. Slide previously shortened and deburred square tube over upper cardan joint end until stop is reached.

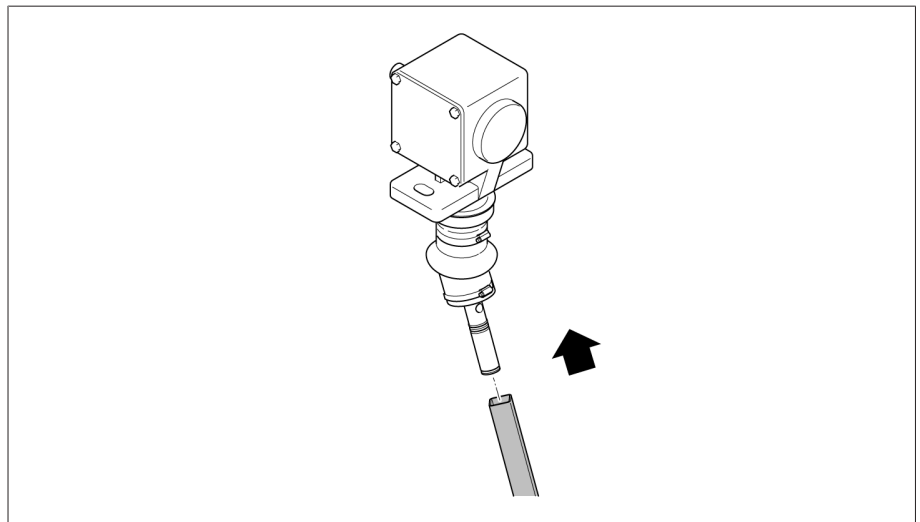

Figure 258: Sliding square tube over upper cardan joint end

12. Thread upper pivotable protective tube with long outlet up onto square tube from below.

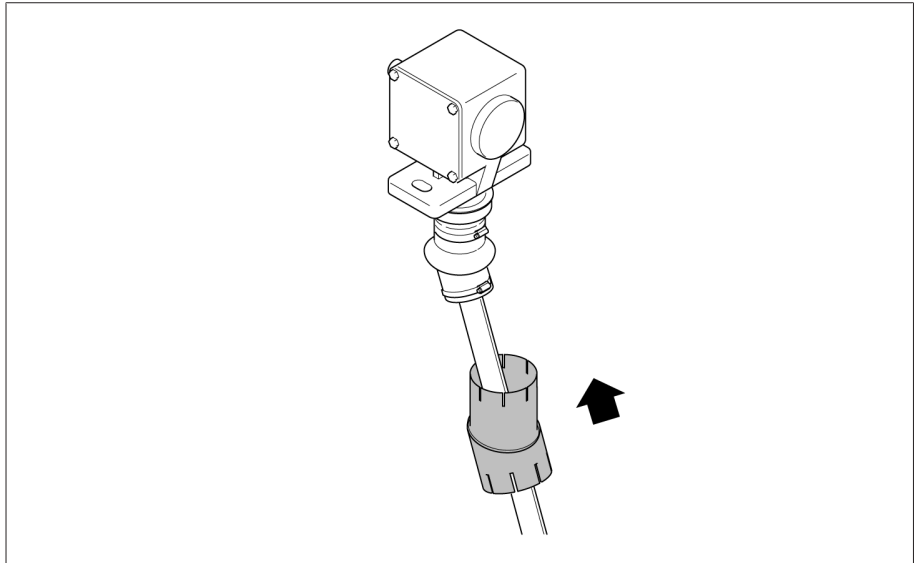

Figure 259: Sliding pivotable protective tube over square tube

13. Slide inner tube into outer tube such that the slotted sides of the outer and inner tube are both facing down. Thread the hose clips.

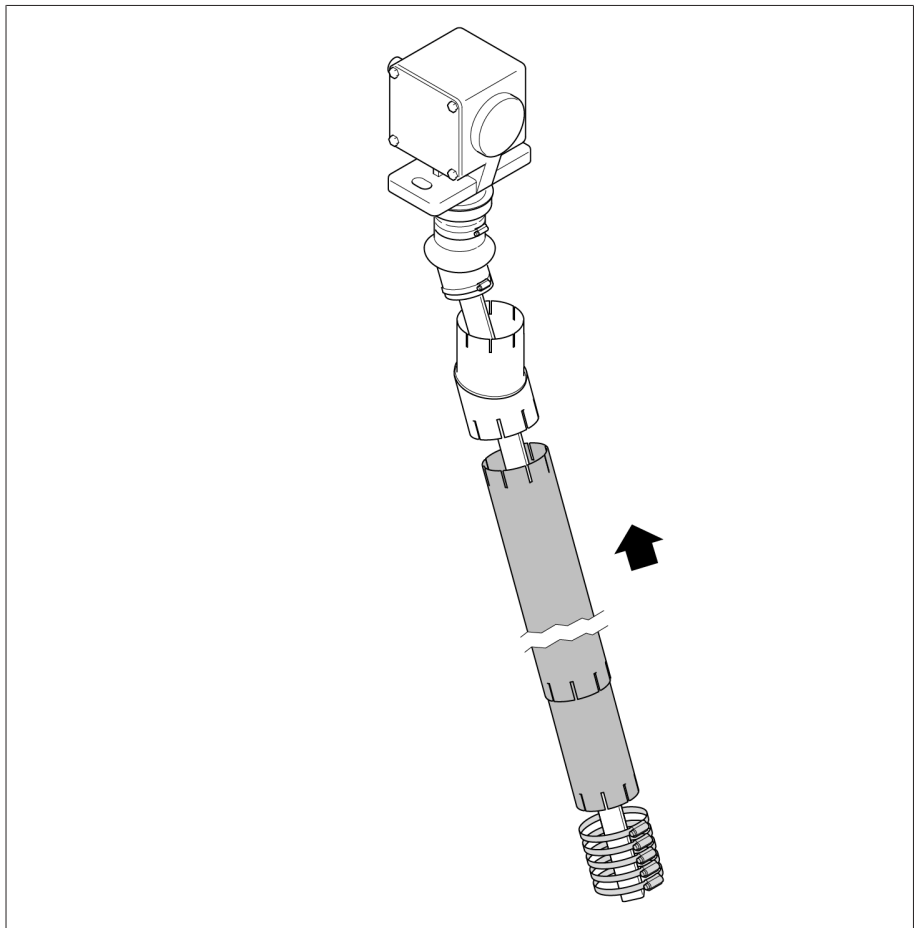

Figure 260: Sliding on telescopic tubes

14. Slide everything up and secure with a screw clamp.

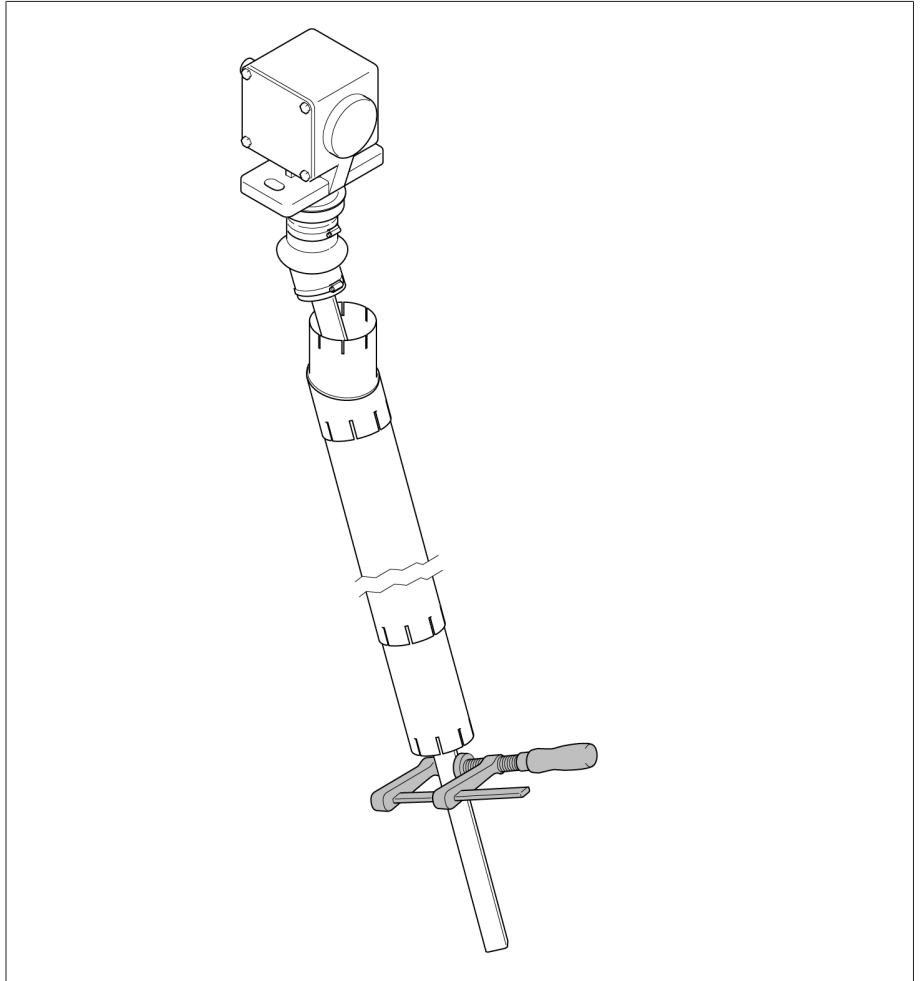

Figure 261: Secure everything with a screw clamp

- Slide bottom pivotable protective tube (also with long outlet up) on to the square tube and secure with screw clamp.

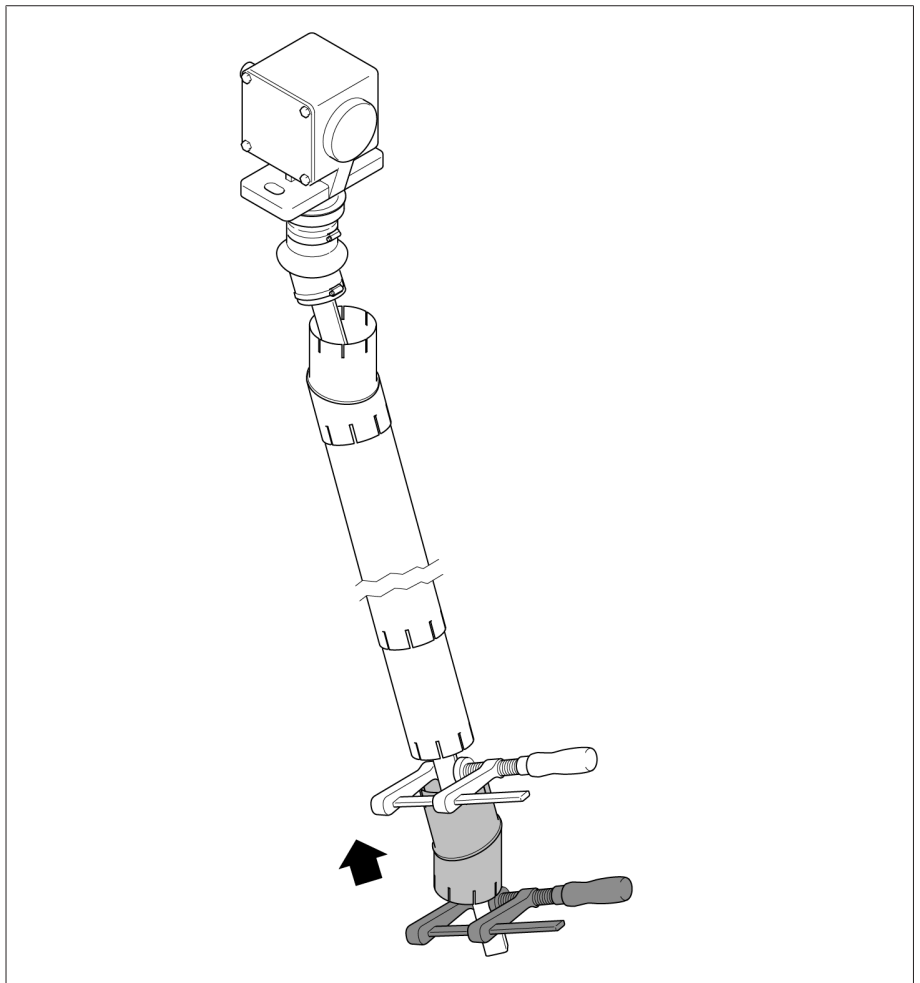

Figure 262: Sliding bottom pivotable protective tube over square tube

16. Swing in square tube and slide all the way down.

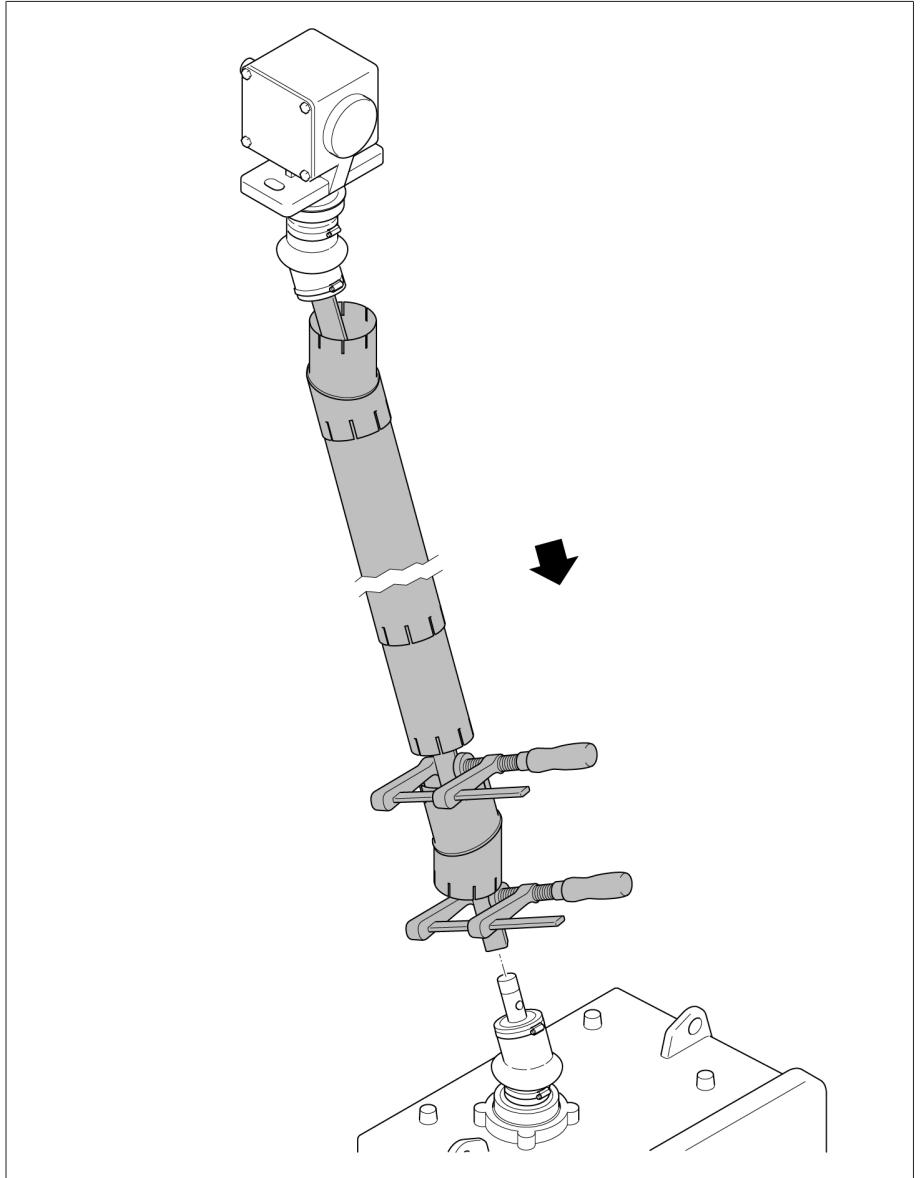

Figure 263: Pivoting square tube back to axis

17. Push the lower coupling bolt in and grease. Tighten lower coupling brackets. Shaft end and coupling part must be securely connected such that no axial clearance remains between the coupling bolt and coupling bracket.

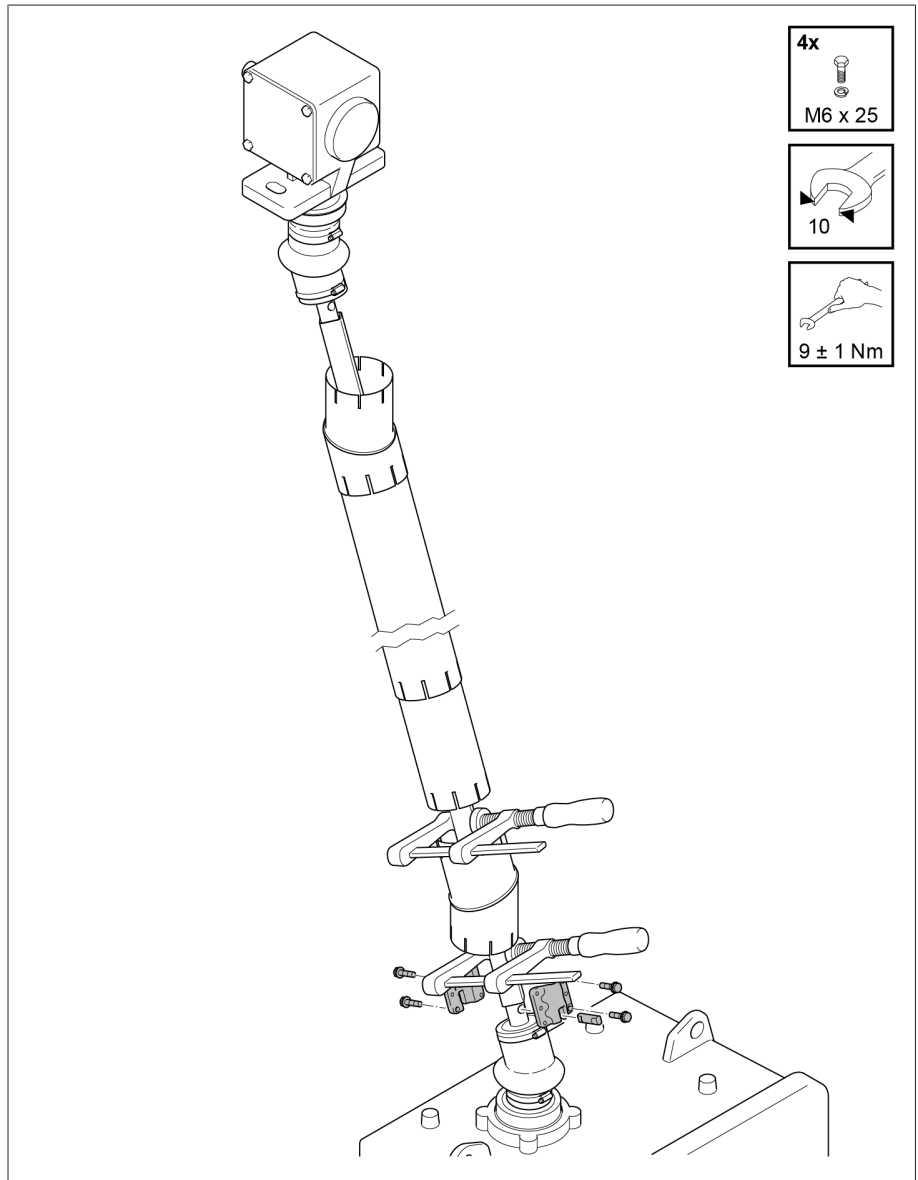

Figure 264: Tightening lower coupling brackets

18. Fit upper coupling brackets with 3 mm axial clearance.

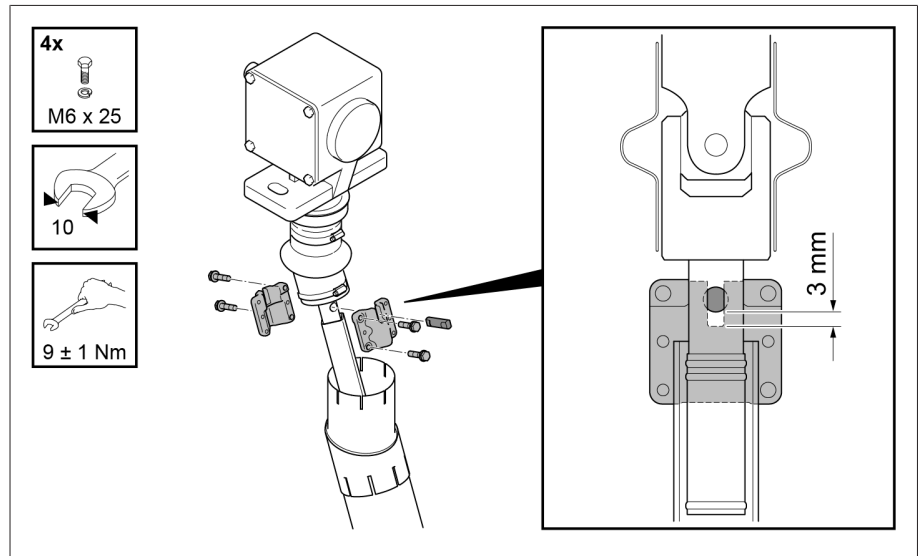

Figure 265: Fitting upper coupling brackets

19 Working from top to bottom, mount the individual parts of the shaft protection. Set angle position between both parts of pivotable protective tube and fix with available hose clip. Secure both upper and lower protective tubes with a hose clip at both ends. Secure the two telescopic protective tubes to one another using a hose clip.

- The plastic adapters must be at the respective end of the pivotable protective tube. Only slide telescopic protective tube into upper and lower pivotable protective tubes by the width of the adapter before tightening the hose clips.

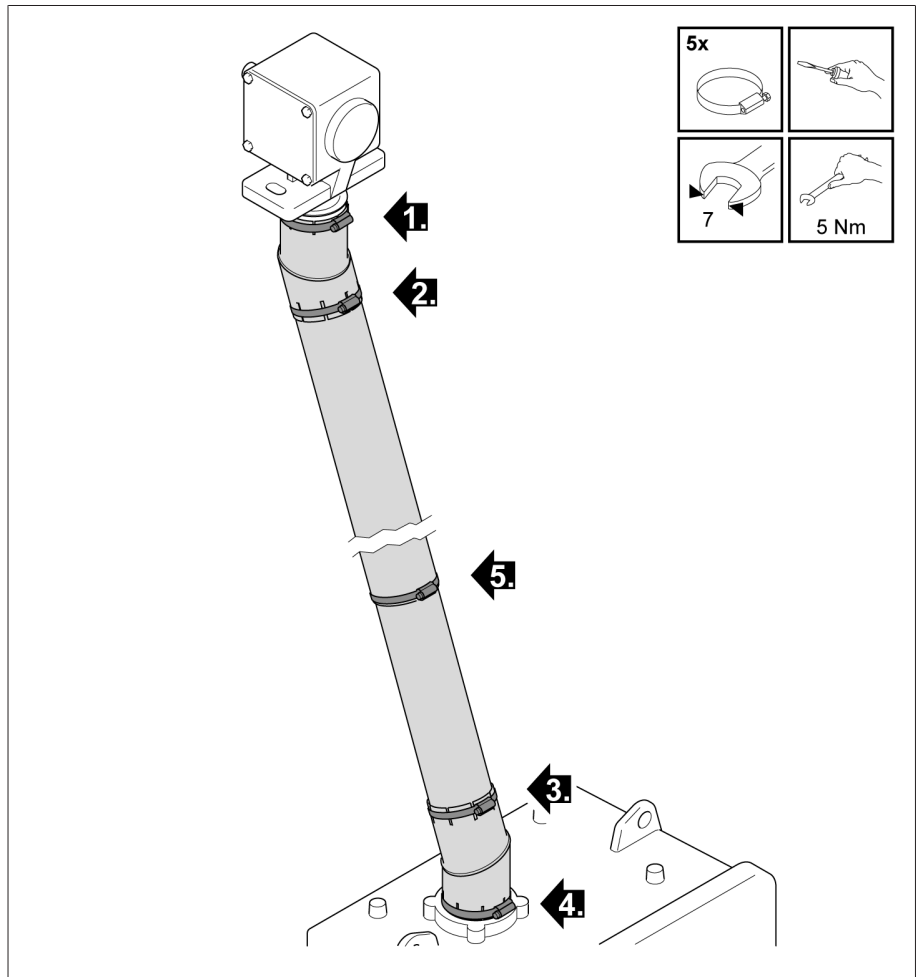

Figure 266: Securing telescopic protective tube and pivotable protective tubes with hose clips

5.4.6.4 Fitting drive shaft with insulator

A model with insulator in the vertical drive shaft is available for insulating installation of the drive shaft.

Permitted axial displacement

Minor axial displacement of the vertical drive shaft with insulator is permitted as long as it does not exceed 35 mm per 1000 mm square tube length (that corresponds to 2°).

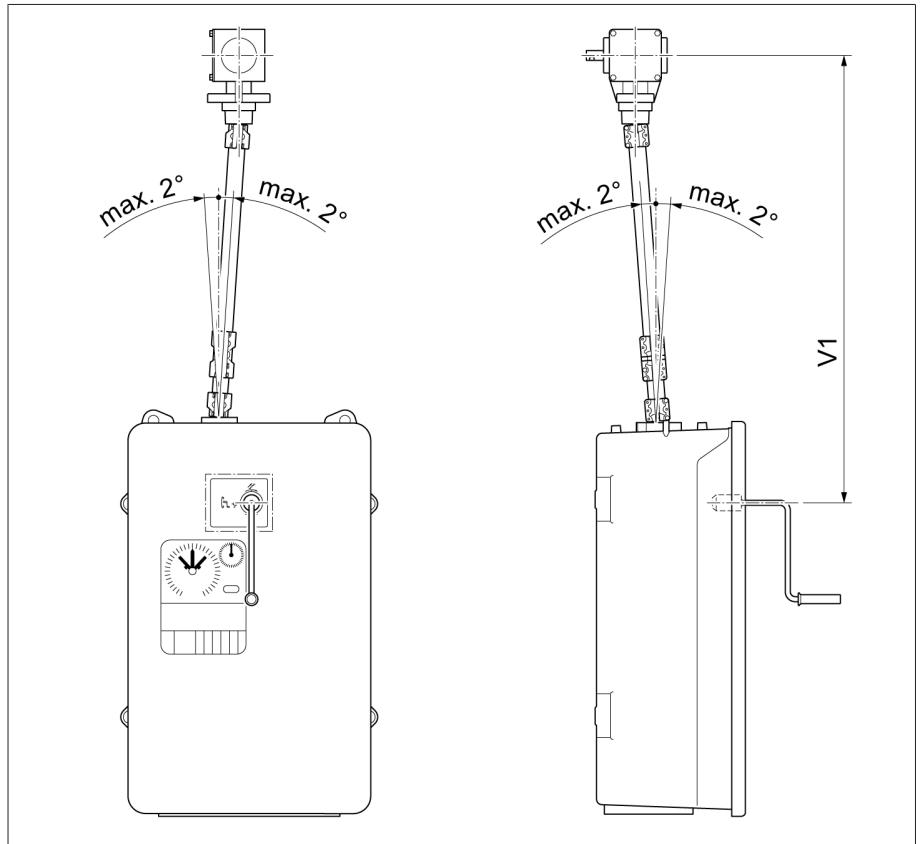

Figure 267: Permitted maximum axial displacement of vertical drive shaft with insulator

5.4.6.4.1 Fitting vertical drive shaft with insulator

To fit the vertical drive shaft, proceed as follows.

1. **⚠ CAUTION!** Switch off motor protective switch Q1 in the motor-drive unit (position O). If this is not done, the motor-drive unit may be started inadvertently and cause injuries.
2. Screw the bevel gear for mounting on the transformer. Screws are not included in the scope of supply.

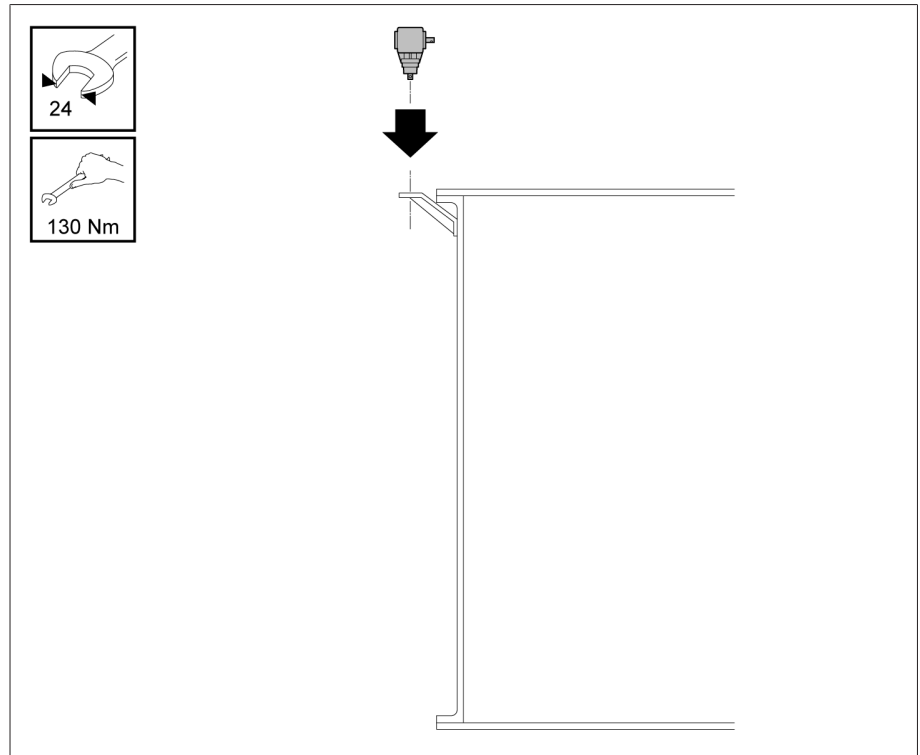

Figure 268: Bevel gear

3. Determine dimension A between shaft end of drive and shaft end of bevel gear. Shorten square tube to length of A-179 mm, taking the insulator into account.

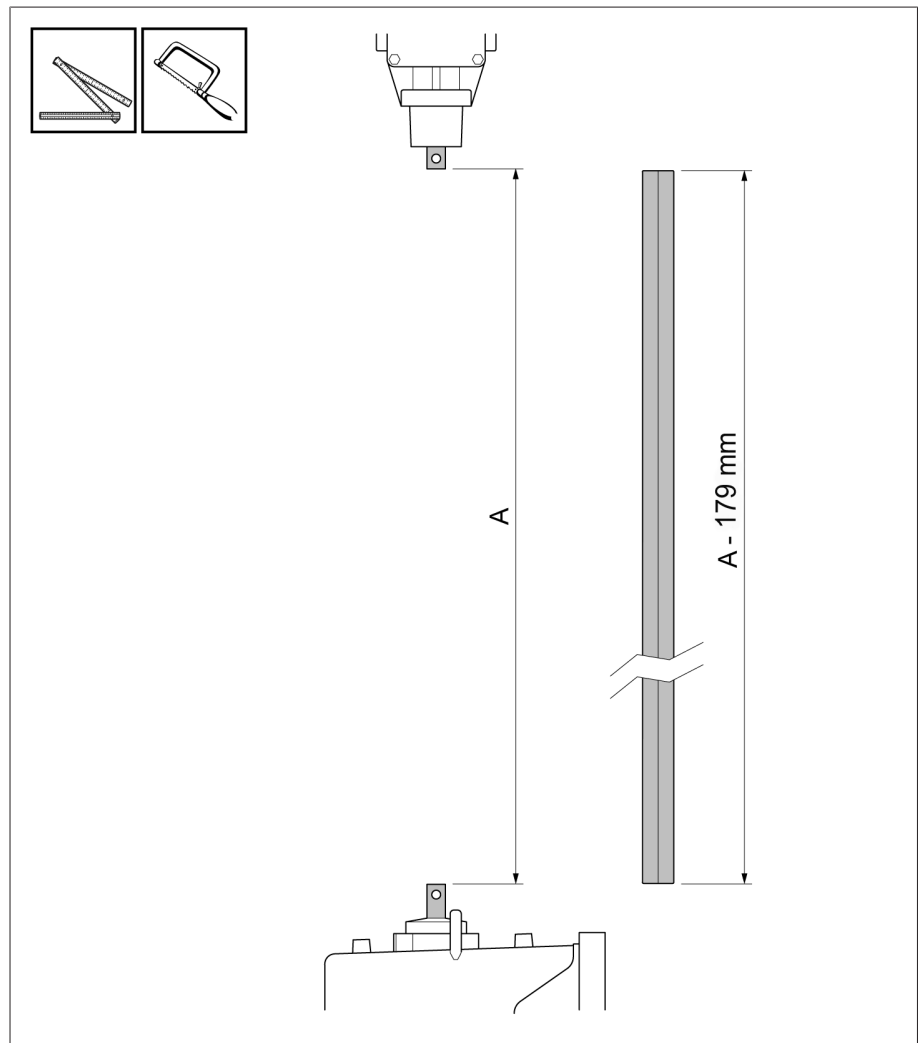

Figure 269: Shortening square tube

4. Deburr cut surfaces of square tube.

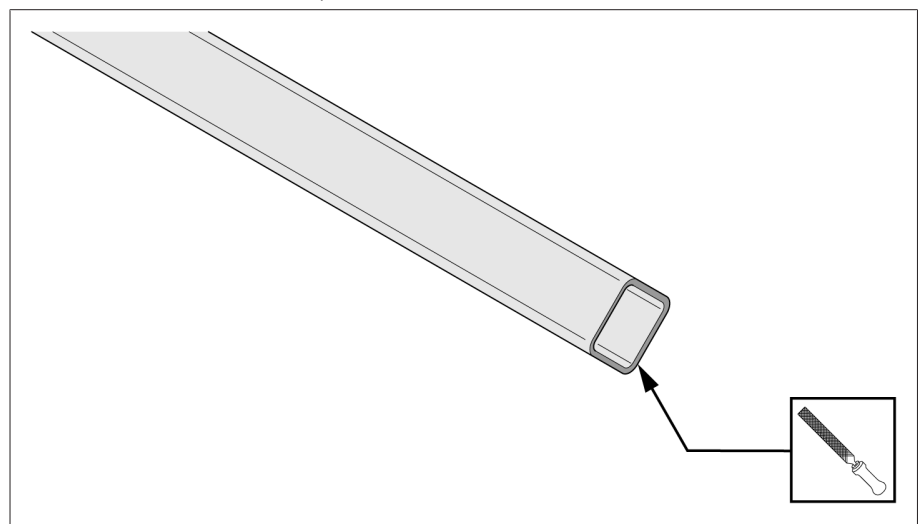

Figure 270: Deburring cut surfaces

5. Screw down double coupling part with insulator supplied and square tube. Mount insulator on the side facing the drive.

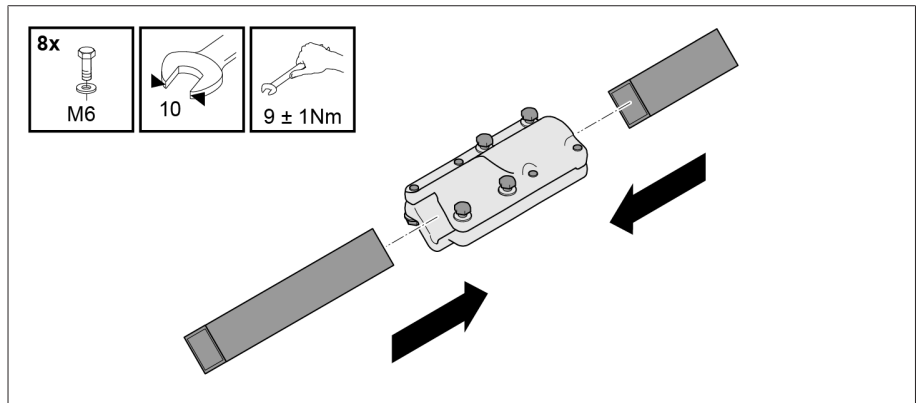

Figure 271: Screwing down square tube and insulator with double coupling part

6. Slide loosely screwed-together coupling part onto insulator until stop is reached.

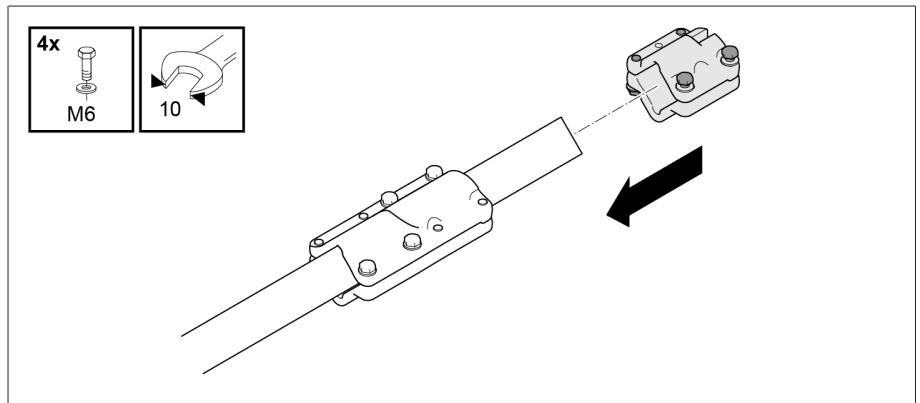

Figure 272: Sliding coupling part onto insulator

7. Place the supplied insulator ring on the bearing collar of the motor-drive unit.

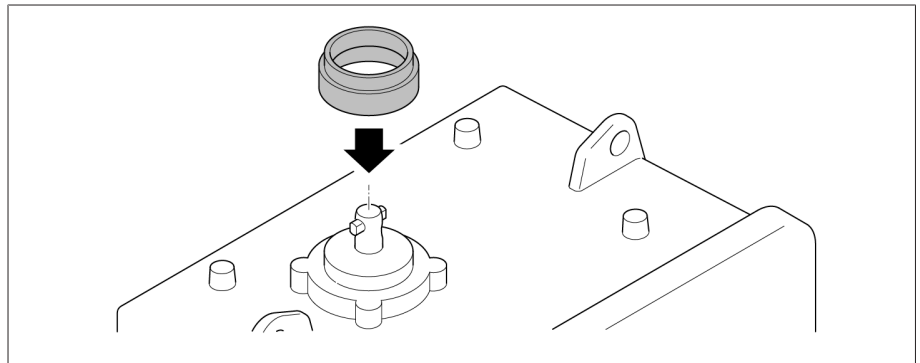

Figure 273: Insulating ring

8. Insert coupling bolt into shaft end of drive. Grease coupling part, coupling bolt and shaft end (e.g. ISOFLEX TOPAS L32). Slide square tube with coupling part onto shaft end.

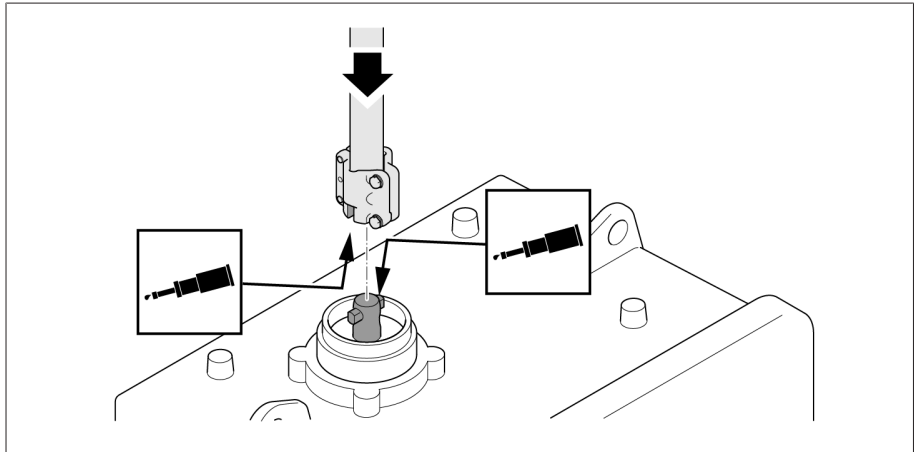

Figure 274: Sliding square tube with coupling part onto shaft end

9. Attach square tube to drive.

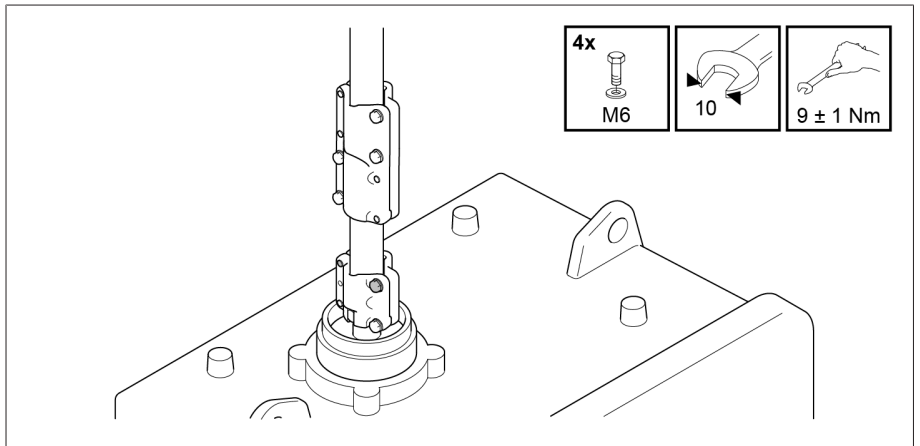

Figure 275: Attaching square tube to drive

10. Pivot square tube away from axis.

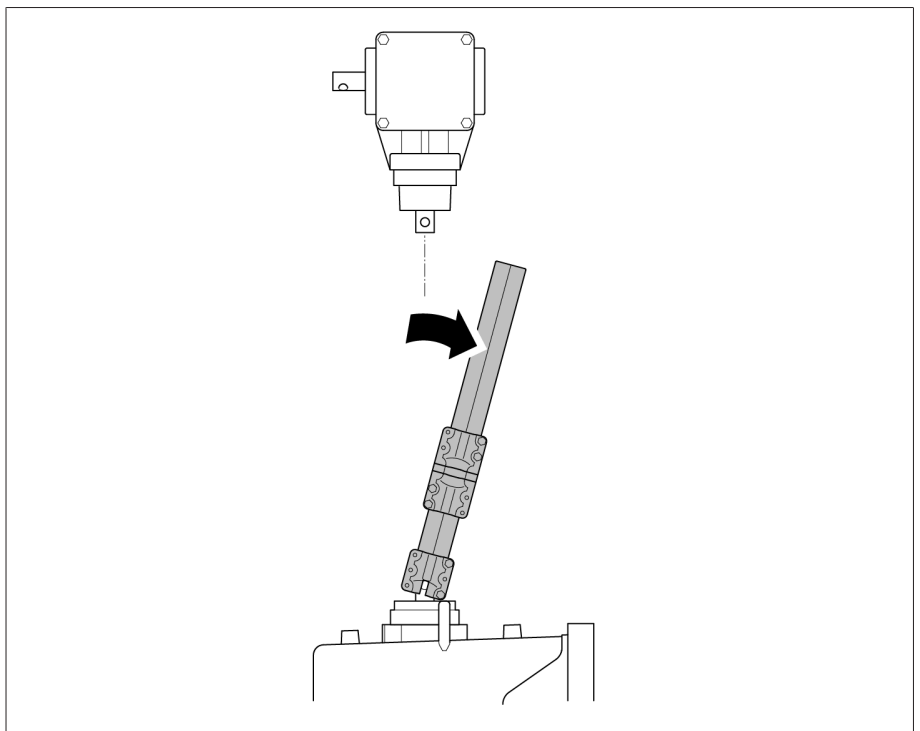

Figure 276: Pivoting square tube away from axis

11. When installing inner tube of telescopic protective tube, shorten on the side without slots if necessary. The minimum dimension for overlapping the two protective tubes is 100 mm.

- Inner tube must not be deformed and must be deburred in order to slide easily in the outer tube.

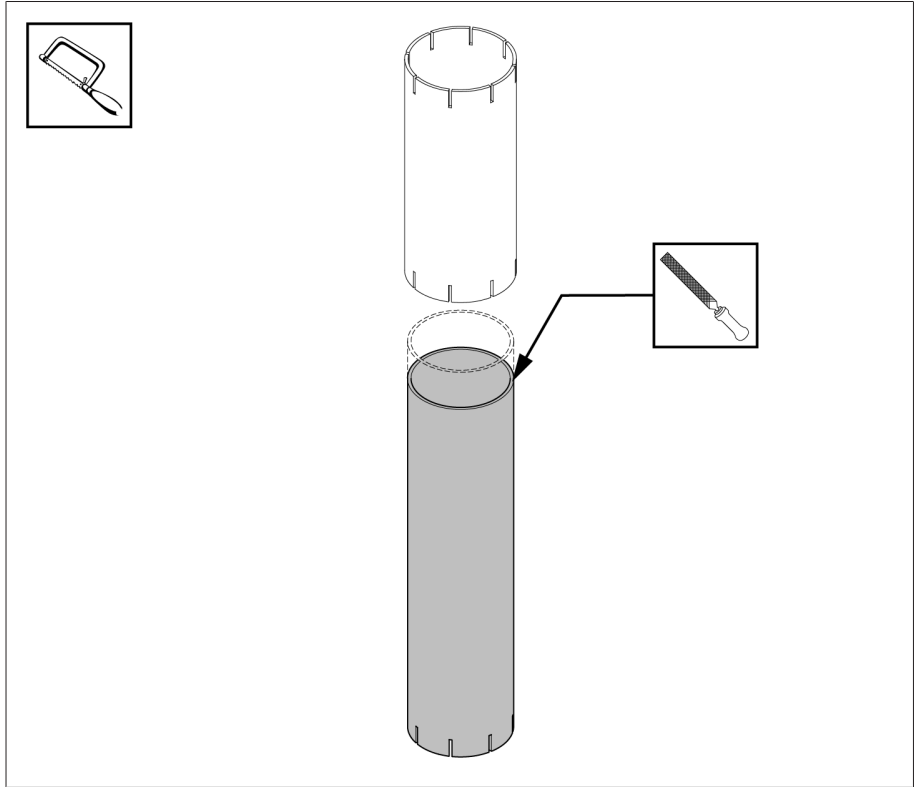

Figure 277: Deburring inner tube

Dimension A (= distance between shaft end of drive and shaft end of bevel gear)	Inner tube	Outer tube
170 mm...190 mm	Shorten to 200 mm	= 200 mm
191 mm...1,130 mm	Dimension A + 20 mm	= 200 mm
1,131 mm...1,598 mm	= 700 mm	= 1,150 mm
1,599 mm...2,009 mm	= 1,150 mm	= 1,150 mm

- Slide outer tube over inner tube. When doing so, make sure that the non-slotted side of the inner tube is facing upwards. Slide telescopic protective tube onto square tube. Then slide hose clips over telescopic protective tube.

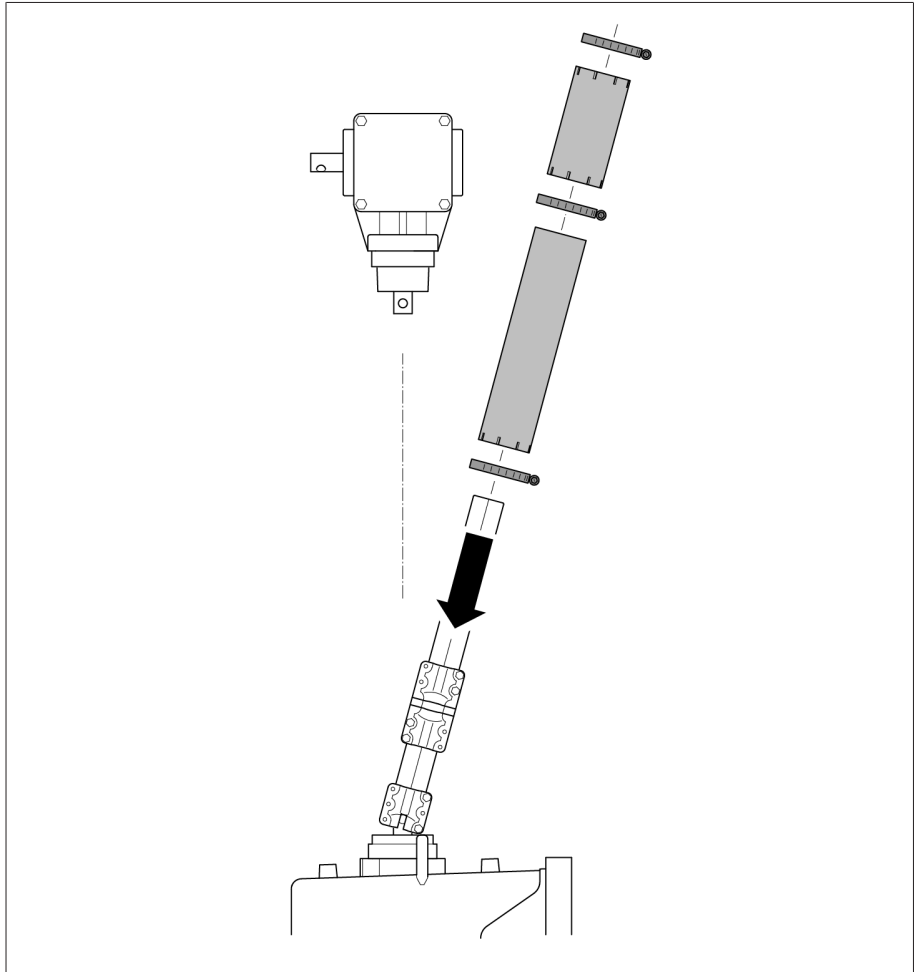

Figure 278: Sliding on telescopic protective tube

13. Place adapter ring over bearing collar of bevel gear and slide upwards. Insert coupling bolt into shaft end of bevel gear. Pivot square tube back to axis.

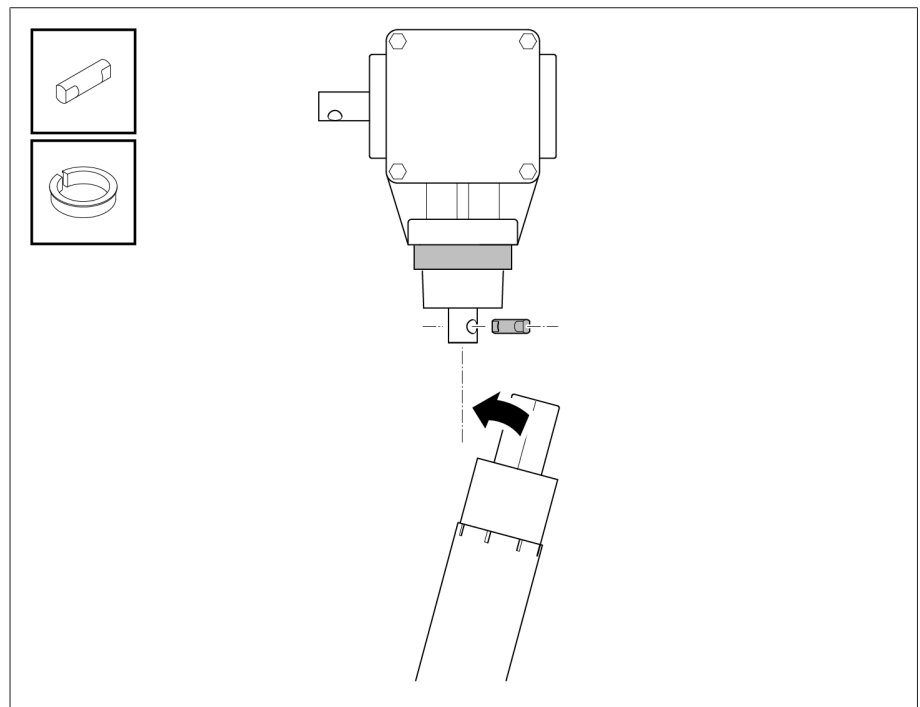

Figure 279: Fitting adapter ring and coupling bolt

14. Grease coupling brackets, coupling bolt and shaft end (e.g. ISOFLEX TOPAS L32) and secure square tube with coupling brackets on the bevel gear. Set a unilateral axial clearance of 3 mm between the coupling bolt and upper coupling piece.

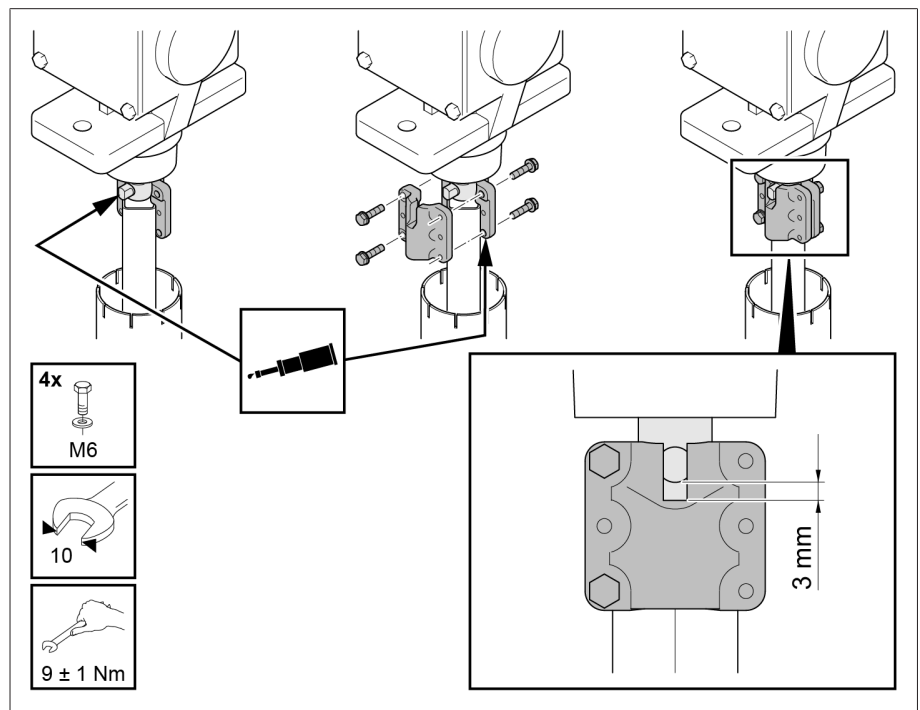

Figure 280: Mounting coupling brackets

- 15 Attach bottom protective tube (inner tube) with a hose clip to bearing collar of drive **1**. Then slide upper protective tube (outer tube) over adapter on bevel gear **2**. Secure upper protective tube to bottom protective tube with hose clip both at top end and at the connection point **3**.

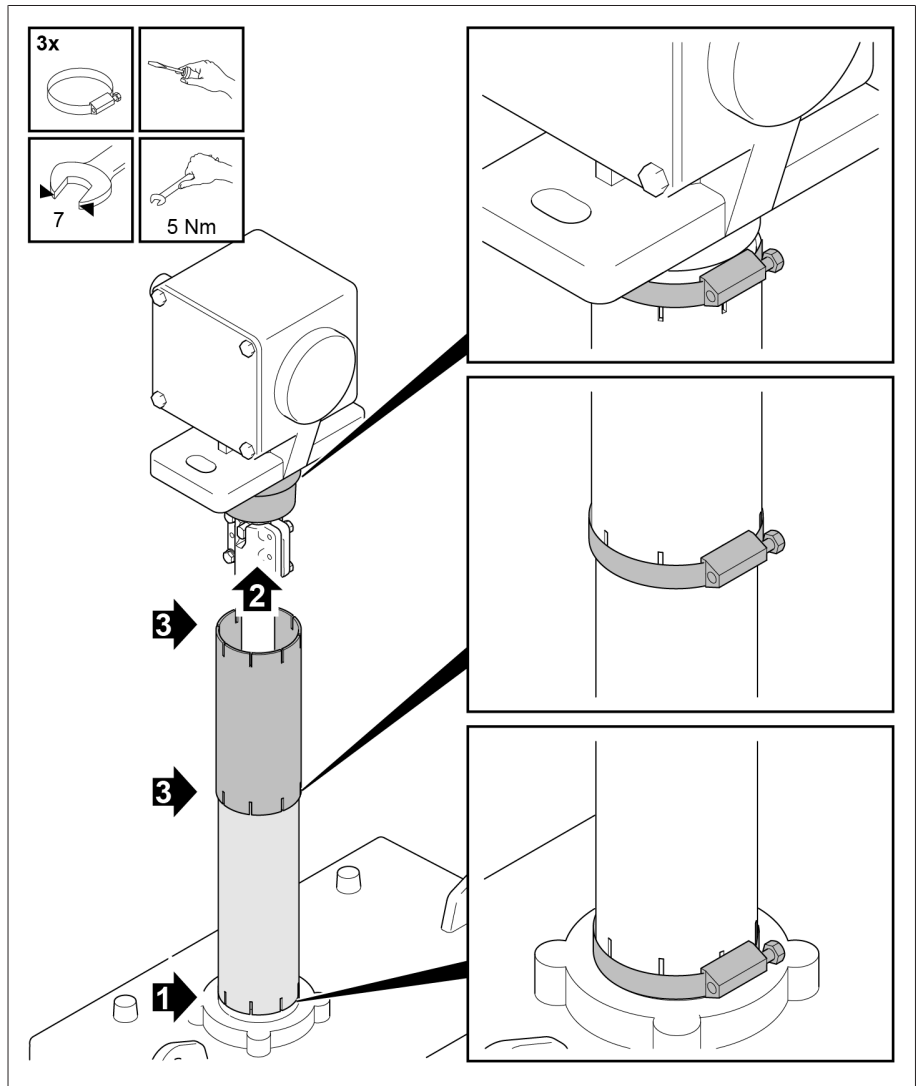

Figure 281: Mounting protective tube

5.4.6.5 Fitting drive shaft with insulator and cardan joint

A model with insulator and cardan joint in the vertical drive shaft is also available for insulating installation of the drive shaft.

Permitted axial displacement

An axial displacement of 20° is permitted for a drive shaft with insulator and cardan joint.

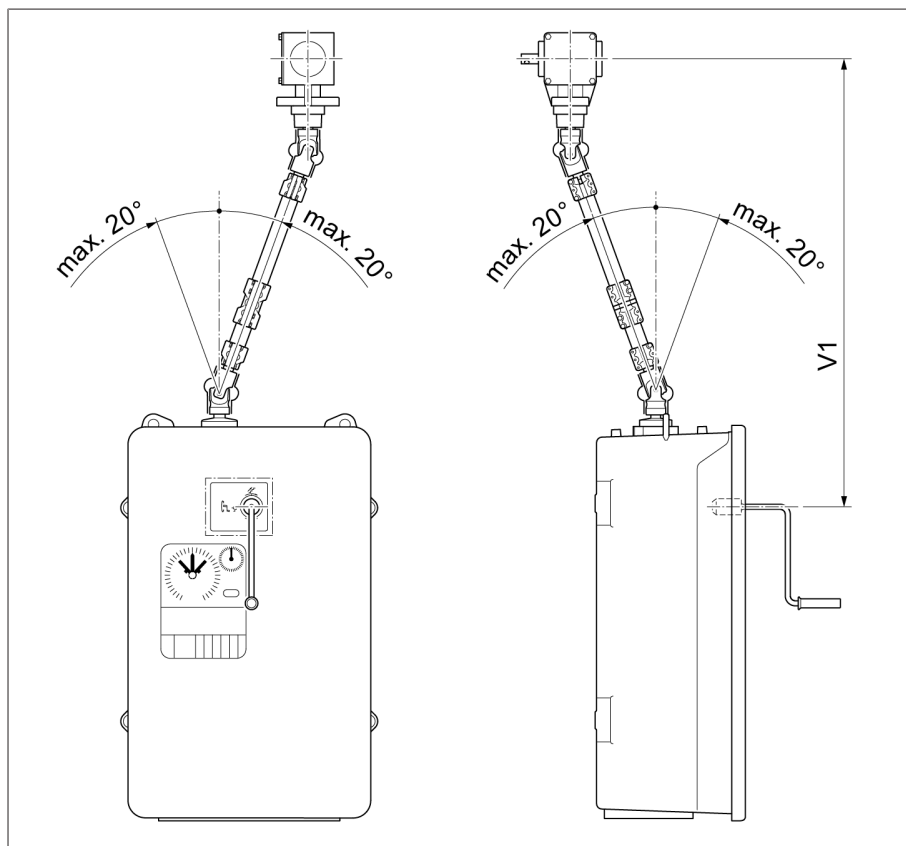

Figure 282: Permitted maximum axial displacement of vertical drive shaft with insulator and cardan joint

5.4.7 Centering on-load tap-changer and motor-drive unit

- › Center on-load tap-changer and motor-drive unit as described in relevant MR operating instructions for motor-drive unit.

5.4.8 Making the electrical connections for the motor-drive unit

- › Make electrical connections for the motor-drive unit as described in relevant MR operating instructions for the motor-drive unit.

6 Commissioning

▲ WARNING



Danger of explosion!

Explosive gases in the oil compartment of the on-load tap-changer, transformer, pipework system, oil conservator and at the dehydrating breather opening can deflagrate or explode and result in severe injury or death!

- > Ensure that there are no ignition sources such as naked flame, hot surfaces or sparks (e.g. caused by the build-up of static charge) in the transformer's immediate surroundings during commissioning and that none occur.
- > Do not operate any electrical devices (e.g. risk of sparks from impact wrench).
- > Only use conductive and grounded hoses, pipes, and pump equipment that are approved for flammable liquids.

▲ WARNING



Danger of explosion!

Overloading the on-load tap-changer can lead to explosion. Spraying hot insulating fluid and flying parts can lead to death and serious injuries. Property damage is highly probable.

- > Ensure that the on-load tap-changer is not overloaded.
- > Ensure use of the on-load tap-changer in accordance with section "Appropriate use".
- > Prevent operations outside of the permitted operating conditions by taking suitable measures.

6.1 Commissioning the on-load tap-changer at the transformer manufacturer's site

Perform the following work and functional checks before commissioning the transformer.

6.1.1 Bleeding on-load tap-changer head and suction pipe

6.1.1.1 Bleeding on-load tap-changer head

1. Open all forward valves and return valves in the pipe system.
2. Remove screw cap on air-vent valve E1 on the on-load tap-changer head cover.

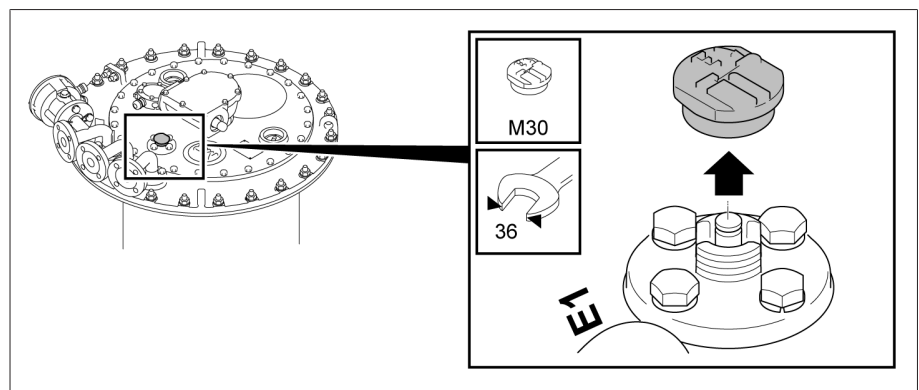

Figure 283: Screw cap

- Use screwdriver to lift valve tappet on air-vent valve E1 and bleed on-load tap-changer head.

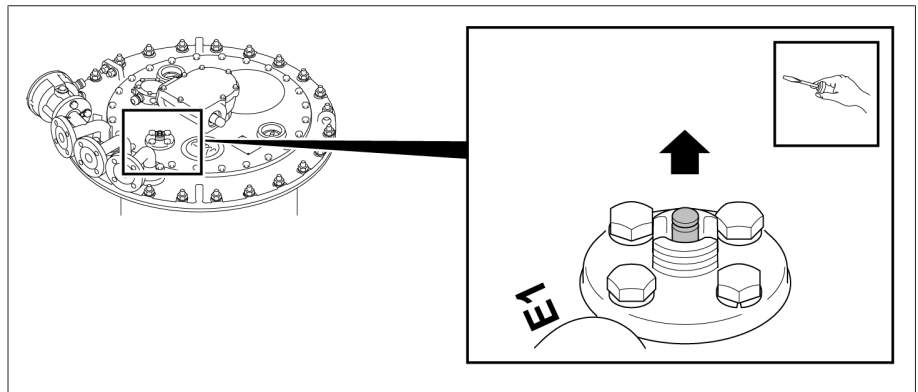

Figure 284: Valve tappet

- Seal air-vent valve E1 with screw cap (tightening torque 10 Nm).

6.1.1.2 Bleeding suction pipe on pipe connection S

- Remove screw cap from pipe connection S.

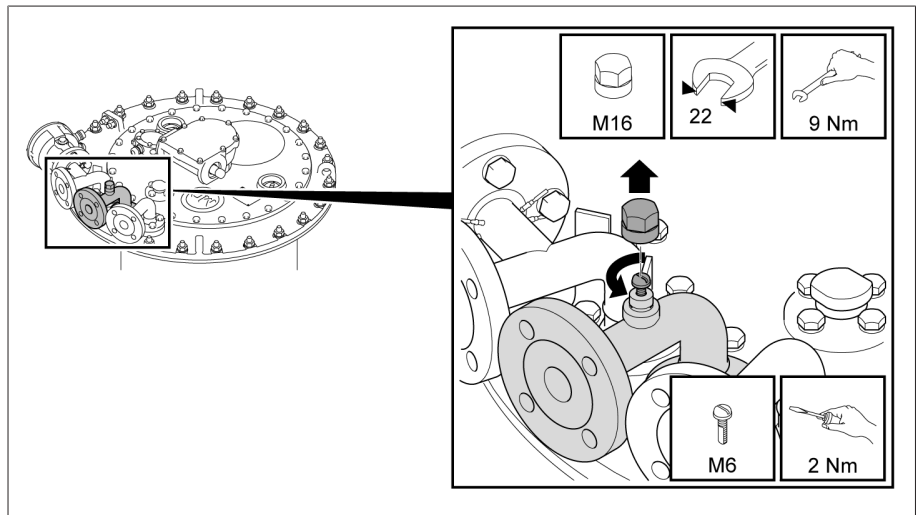

Figure 285: Screw cap

- NOTICE!** An incompletely bled suction pipe significantly impairs the insulation capability of the on-load tap changer to ground. Open vent screw and bleed suction pipe completely.
- Close vent screw.
- Seal vent screw with screw cap.

6.1.2 Grounding the on-load tap-changer

1. Connect grounding screw on the on-load tap-changer head to transformer cover. It is essential that CUPAL washers are placed directly on the connecting lug on both sides. The aluminum side of the CUPAL washers must be facing the connecting lug.

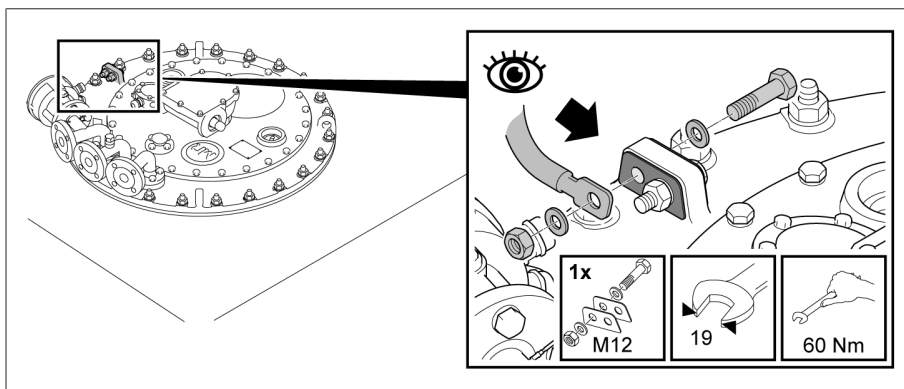

Figure 286: Grounding screw head

2. Connect grounding screw of motor-drive protective housing to transformer tank. It is essential that a CUPAL washer is placed between the cable shoe and connecting lug. The aluminum side of the CUPAL washer must be facing the connecting lug.

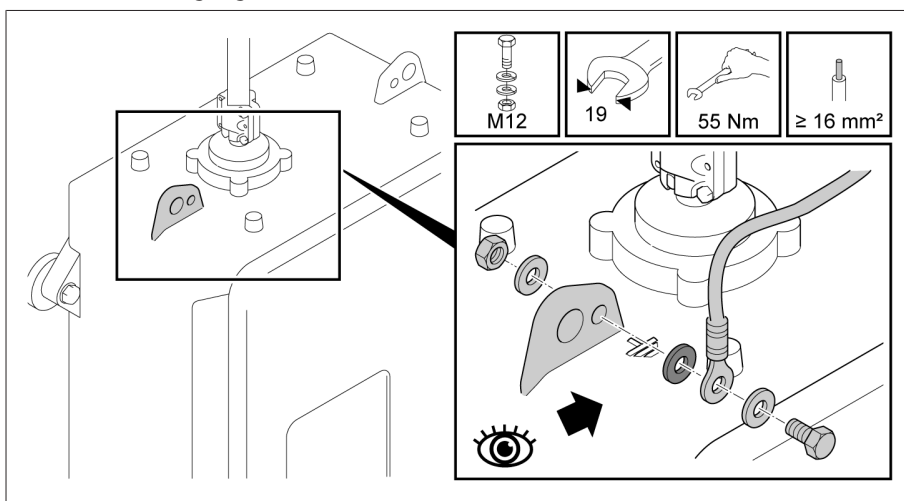

Figure 287: Grounding screw on motor-drive unit

3. When using a temperature sensor, connect housing of temperature sensor with grounding screw on the on-load tap-changer head or another grounding point on the transformer. It is essential that a CUPAL washer is placed between the cable shoe and temperature sensor housing. The aluminum side of the CUPAL washer must be facing the temperature sensor housing.

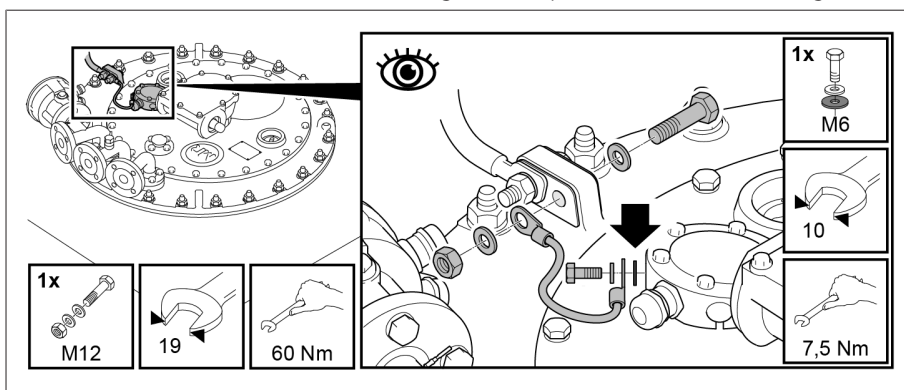

Figure 288: Grounding temperature sensor

6.1.3 Checking motor-drive unit

NOTICE

Damage to the on-load tap-changer / de-energized tap-changer!

Damage to the on-load tap-changer / de-energized tap-changer due to actuation of the on-load tap-changer / de-energized tap-changer without insulating fluid.

- Ensure that the selector / de-energized tap changer is fully immersed in insulating fluid and that the oil compartment of the on-load tap-changer is completely filled with insulating fluid.

Prior to commissioning the transformer, check whether the motor-drive unit and on-load tap-changer are correctly coupled and that the motor-drive unit functions correctly.

Tests on the motor-drive unit

1. Perform function checks as described in relevant MR operating instructions for motor-drive unit.
2. **NOTICE!** An incorrectly coupled motor-drive unit will lead to damage to the on-load tap-changer. Undertake trial tap-change operations across the entire range of settings. Ensure that in each operating position, the tap position indicators of motor-drive unit and on-load tap-changer (inspection window in the on-load tap-changer head) match.

Dielectric tests on transformer wiring

- Note information relating to dielectric tests on transformer wiring in relevant MR operating instructions for motor-drive unit.

6.1.4 High-voltage tests on the transformer

NOTICE

Damage to the on-load tap-changer!

Damage to the on-load tap-changer due to impermissibly high test voltages and operating voltages.

- Ensure that the permissible test voltages and operating voltages [► Section 8.6, Page 206] are complied with for on-load tap-changers for Y connection with open neutral point.

Note the following points before performing high-voltage tests on the transformer:

- Ensure that the oil compartment of the on-load tap-changer is completely filled with insulating fluid.
- Ensure that all protective devices for the on-load tap-changer are functioning correctly and are ready for use.
- Ensure that the ground connections on the motor-drive protective housing and protective housing fastening are free of paint.
- Only perform high voltage test if motor-drive unit door is closed.
- Disconnect external connections to electronic components in the motor-drive unit to prevent damage from overvoltage.
- When connecting the motor-drive unit's supply voltage, only use the cable bushings in the protective housing base intended for lead insertion.
- Guide all ground connecting leads to one central connection point (establishment of suitable reference earth).
- Disconnect all electronic components before the high voltage test. Before a dielectric test of the wiring, remove all devices with a withstand voltage of < 1000 V.
- Remove leads used for testing before the high voltage test as these function as antennas.
- Wherever possible, route the measurement leads and data leads separately to the energy cables.

Contact the manufacturer if you have any questions about possible sources of danger.

6.2 Transporting transformer to the operating site

NOTICE

Damage to motor-drive unit!

Damage to the motor-drive unit due to condensate in protective housing of motor-drive unit.

- > Always keep protective housing of the motor-drive unit tightly closed.
- > In the event of downtime lasting more than 8 weeks prior to initial commissioning, connect and operate the heater in the motor-drive unit. If this is not possible, place a sufficient amount of desiccant in the protective housing.

6.2.1 Transport with drive removed

1. Ensure that the drive and the on-load tap-changer are in the adjustment position.
2. Remove the drive.
3. Do not actuate the drive while the on-load tap-changer is uncoupled and do not turn the output shaft.
4. Do not actuate an on-load tap-changer which is uncoupled and do not turn its drive shaft.
5. Transport the drive to the installation site in the MR delivery packaging.
6. Fit the drive [► Section 5.4.5, Page 131] and the drive shaft [► Section 5.4.6, Page 131] to the transformer at the installation site.

6.2.2 Transport with full transformer tank and without oil conservator

Attach a connecting lead between the on-load tap-changer's oil compartment and the transformer tank if the transformer has been transported with a full tank and without an oil conservator.

- > Establish a connecting lead on the on-load tap-changer head between connections E2 and Q or E2 and R.

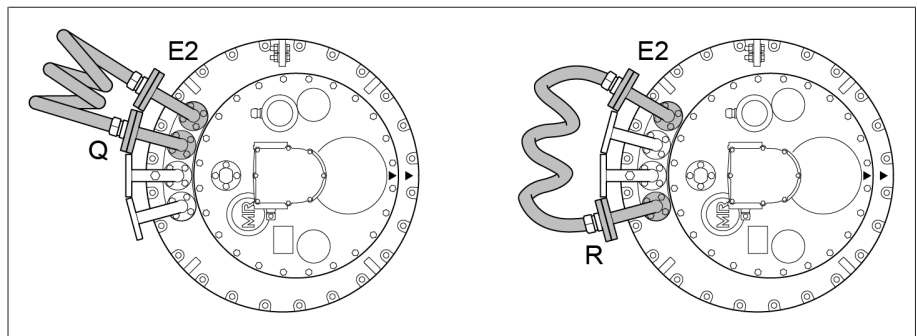

Figure 289: Connecting lead



In the event of a short-term immobilization time (maximum of 4 weeks) without an oil conservator, it is also sufficient to remove approximately 5 liters of insulating fluid from the on-load tap-changer oil compartment.

6.2.3 Transport with empty transformer tank

Damage to the on-load tap-changer!

The on-load tap-changer may be subject to oscillating movements during transformer transportation if the transformer is transported without insulating fluid and the on-load tap-changer oil compartment is transported with insulating fluid. These oscillating movements can lead to damage to the on-load tap-changer.

- › Completely empty the oil compartment if the transformer is to be transported without insulating fluid.
- › Preserve the oil compartment in the same way as the transformer (for example by filling with N₂).

6.2.3.1 Emptying oil compartment via pipe connection S

1. De-energize all auxiliary circuits (e.g tap-change supervisory device, pressure relief device, pressure monitoring device).
2. With the stop-cock (slide valve) between oil conservator and oil compartment open, open air-vent valve E1 on the on-load tap-changer head.
3. Discharge the gas from under the on-load tap-changer cover. Ensure sufficient fresh air (e.g. in transformer cells and work tents) when doing so.
4. Once the gas has been discharged and the insulating fluid is flowing out of the air-vent valve, close the air-vent valve and close the stop-cock between the oil conservator and oil compartment.
5. Open air-vent valve again and drain off approximately 5–10 liters of insulating fluid via the pipe connection S until the area under the on-load tap-changer head cover is free of insulating fluid.
6. Loosen 24 screws M10 / wrench size 17 with locking elements on the on-load tap-changer head cover.
7. Remove on-load tap-changer head cover.
8. Extract insulating fluid via pipe connection S.
9. Open stop-cock between oil conservator and oil compartment.
 - » Insulating fluid flows out of the oil conservator into the oil compartment.
10. Extract insulating fluid via pipe connection S.
11. Place on-load tap-changer head cover on the on-load tap-changer head.
12. Screw down on-load tap-changer head cover using 24 screws M10 / wrench size 17 and locking elements (tightening torque 34 Nm).

6.3 Commissioning transformer at operating site

6.3.1 Filling the oil compartment of the on-load tap-changer with insulating fluid

NOTICE

Damage to the on-load tap-changer!

Unsuitable insulating fluids cause damage to the on-load tap-changer.

> Only use insulating fluids [► Section 8.1.2, Page 198] approved by the manufacturer.

1. **NOTICE!** Check whether the on-load tap-changer head cover has a flange for attaching a pressure relief device. If it does, operation without a pressure relief device is not permitted and may result in damage to the on-load tap-changer.
 - » Fit a pressure relief device which is approved for this on-load tap-changer on the on-load tap-changer head.
2. Establish a connecting lead between pipe connection E2 and one of the pipe connections R, S or Q to ensure equal pressure in the oil compartment and transformer during evacuation.

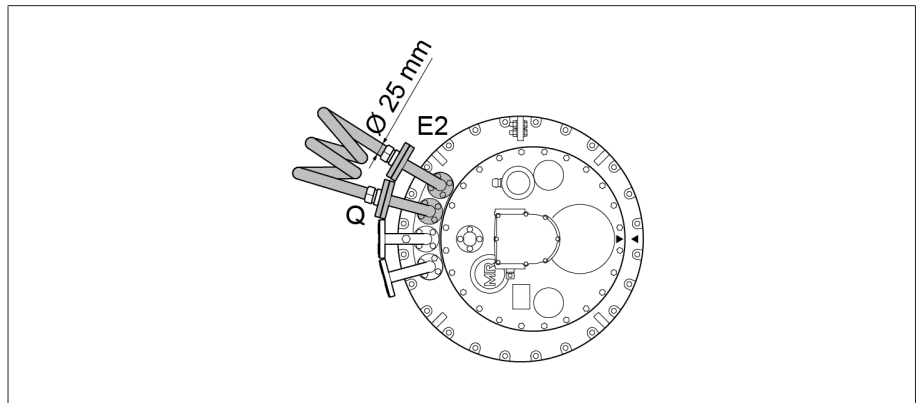

Figure 290: Connecting lead between E2 and Q

3. Fill on-load tap-changer with new insulating fluid using one of the two free pipe connections of the on-load tap-changer head.

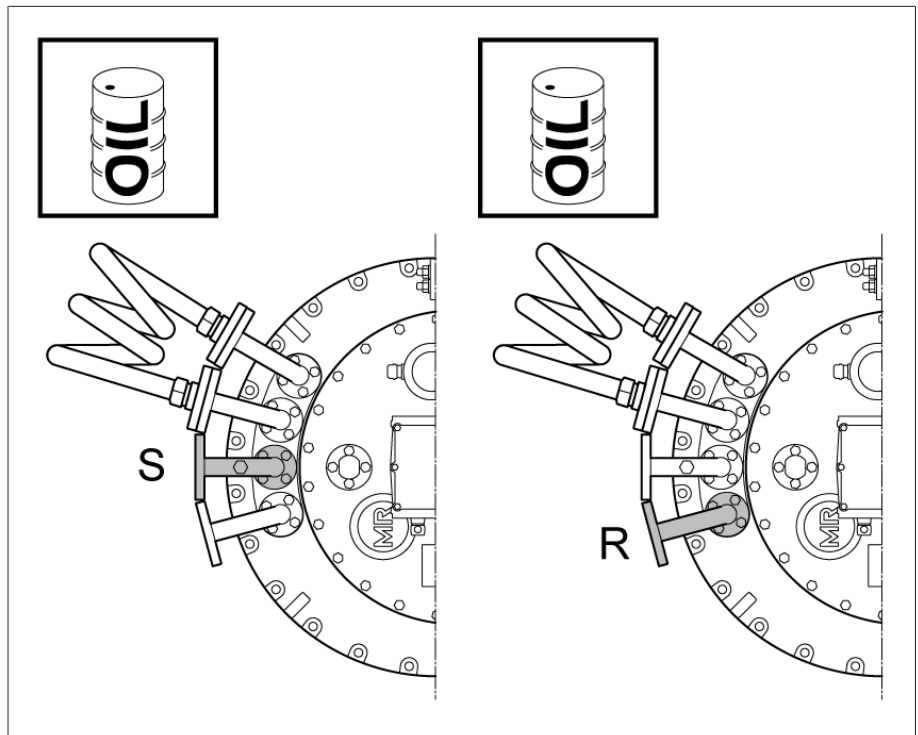

Figure 291: Pipe connections S and R

4. Take an insulating fluid sample from the oil compartment.
5. Record the temperature of the sample immediately after the sample is taken.
6. Determine dielectric strength and water content at a sample temperature of $20^{\circ}\text{C} \pm 5^{\circ}\text{C}$. The dielectric strength and water content must comply with the limit values specified in the technical data.

6.3.2 Bleeding on-load tap-changer head and suction pipe

6.3.2.1 Bleeding on-load tap-changer head

1. Open all forward valves and return valves in the pipe system.
2. Remove screw cap on air-vent valve E1 on the on-load tap-changer head cover.

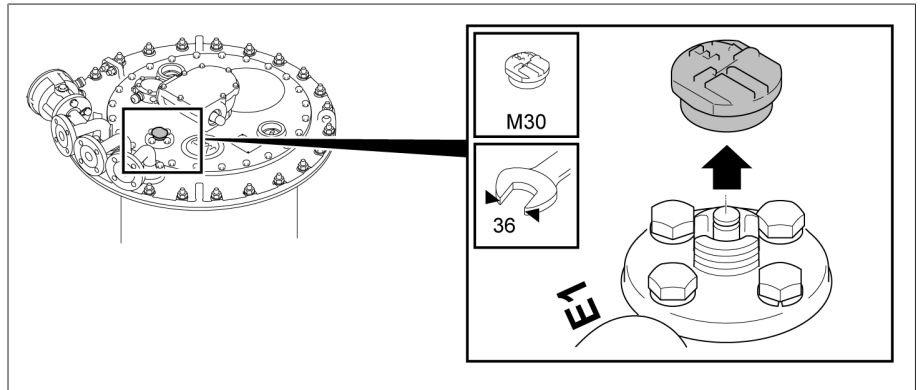

Figure 292: Screw cap

3. Use screwdriver to lift valve tappet on air-vent valve E1 and bleed on-load tap-changer head.

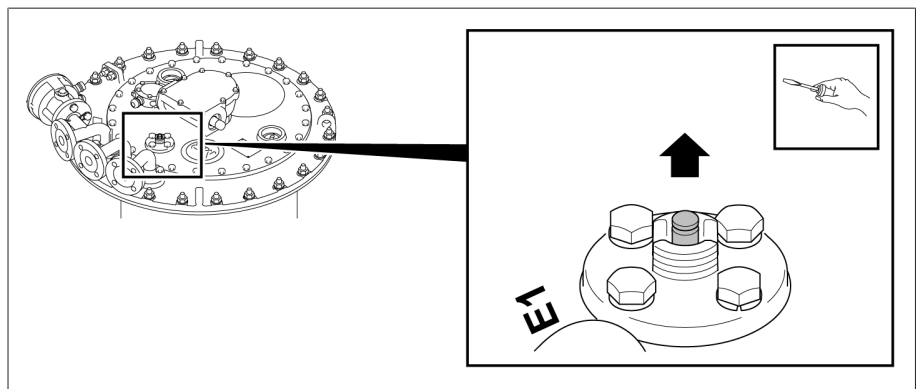

Figure 293: Valve tappet

4. Seal air-vent valve E1 with screw cap (tightening torque 10 Nm).

6.3.2.2 Bleeding suction pipe on pipe connection S

1. Remove screw cap from pipe connection S.

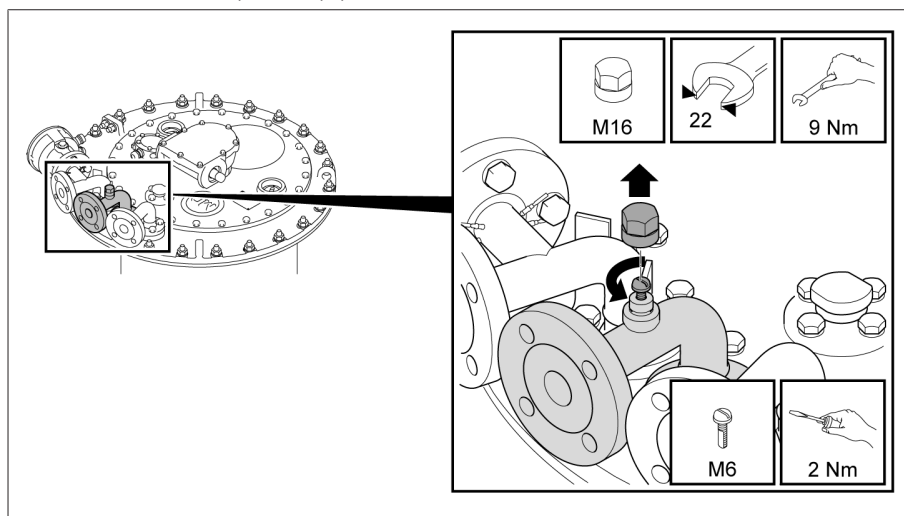

Figure 294: Screw cap

2. **NOTICE!** An incompletely bled suction pipe significantly impairs the insulation capability of the on-load tap changer to ground. Open vent screw and bleed suction pipe completely.
3. Close vent screw.
4. Seal vent screw with screw cap.

6.3.3 Checking motor-drive unit

NOTICE

Damage to the on-load tap-changer / de-energized tap-changer!

Damage to the on-load tap-changer / de-energized tap-changer due to actuation of the on-load tap-changer / de-energized tap-changer without insulating fluid.

- > Ensure that the selector / de-energized tap changer is fully immersed in insulating fluid and that the oil compartment of the on-load tap-changer is completely filled with insulating fluid.

NOTICE

Damage to the on-load tap-changer and motor-drive unit!

Damage to on-load tap-changer and motor-drive unit due to incorrect use of position transmitter equipment.

- > Only circuits stated in the chapter Technical data for position transmitter equipment may be connected to the position transmitter module connections.
- > The switchover point of the position transmitter equipment in the motor-drive unit is not the same as the switchover point of the diverter switch operation. This depends on the type of diverter switch. This fact should be noted when project planning the locking circuits between the motor-drive unit and external equipment (e.g. transformer circuit breaker).
- > Therefore, the "Tap changer in operation" position transit contact shown in the connection diagram should be used for external monitoring, locking and control purposes instead of the position transmitter equipment.

Prior to commissioning the transformer, check whether the motor-drive unit and on-load tap-changer are correctly coupled and that the motor-drive unit functions correctly.

Tests on the motor-drive unit

1. Perform function checks as described in relevant MR operating instructions for motor-drive unit.
2. **NOTICE!** An incorrectly coupled motor-drive unit will lead to damage to the on-load tap-changer. Undertake trial tap-change operations across the entire range of settings. Ensure that in each operating position, the tap position indicators of motor-drive unit and on-load tap-changer (inspection window in the on-load tap-changer head) match.

Dielectric tests on transformer wiring

- > Note information relating to dielectric tests on transformer wiring in relevant MR operating instructions for motor-drive unit.

6.3.4 Checking protective relay

6.3.4.1 Checking protective relay (RS 2001, 2001/V, 2001/H, 2001/E, 2001/5, 2001/R, 2001/T, 2003)

- ✓ Check that the protective relay is functioning correctly before commissioning the transformer:
 1. Ground the transformer on the high-voltage side and low-voltage side. Ensure that the grounding for work connection on the transformer is not removed during testing.
 2. Ensure that the transformer remains de-energized during testing.
 3. Deactivate the automatic fire extinguishing device.
 4. Loosen the three screws on the terminal box cover and lift off the terminal box cover.
 5. Remove the slotted head screw for potential tie-in and remove the terminal box cover with wire.
 6. Press OFF test button.
 7. Leave the transformer's danger zone.
 8. Ensure that the transformer's circuit breaker cannot be closed.
 - » Passive protection test
 9. Press OPERATION test button.
 10. Leave the transformer's danger zone.
 - .
 11. Close the transformer's circuit breaker with isolating switches open and the transformer grounded on all sides.
 12. Press OFF test button.
 - .
 13. Ensure that the transformer's circuit breaker is open.
 - ⇒ Active protection test.
 14. Press OPERATION test button to reset the protective relay.
 15. Position the wire for the terminal box cover and affix using the slotted head screw.
 16. Attach the terminal box cover and secure with screws.
 - .

6.3.4.2 Checking protective relay (RS 2004)

- ✓ Check that the protective relay is functioning correctly before commissioning the transformer:
 1. Ensure that the flap valve is in the OPERATION position.
 2. Leave the transformer's danger zone.
 3. Close the transformer's circuit breaker with isolating switches open and the transformer grounded on all sides.
 4. Press OFF test button.

5. Ensure that the transformer's circuit breaker is open.
 - » Active protection test

6.3.5 Checking pressure monitoring device

1. Ground the transformer on the high-voltage side and low-voltage side. Ensure that the grounding for work connection on the transformer is not removed during testing.
2. Ensure that the transformer remains de-energized during testing.
3. Deactivate the automatic fire extinguishing device.
4. Remove the cover cap.
5. Activate the sensor on the snap-action switch.
 - » Sensor is in the OFF position.
6. Leave the transformer's danger zone.
7. Ensure that the transformer's circuit breaker cannot be closed.
 - » Passive protection test
8. Activate the sensor on the snap-action switch.
 - » Sensor is in the OPERATION position.
9. Leave the transformer's danger zone.
10. Close the transformer's circuit breaker with isolating switches open and the transformer grounded on all sides.
11. Activate the sensor on the snap-action switch.
 - ⇒ Sensor is in the OFF position.
12. Ensure that the transformer's circuit breaker is open.
 - ⇒ Active protection test.
13. Activate the sensor on the snap-action switch to reset the pressure monitoring device.
 - ⇒ Sensor is in the OPERATION position.
14. Secure the cover cap.

6.3.6 Commissioning the transformer

- ✓ The signaling contact for falling below the minimum insulating fluid fill level in the on-load tap-changer's oil conservator is looped into the tripping circuit of the circuit breaker.
 - ✓ The protective relay and additional protective devices are looped into the circuit breaker's tripping circuit.
 - ✓ The motor-drive unit and all protective devices are functioning correctly and are ready for use.
 - ✓ The oil compartment of the on-load tap-changer is completely filled with insulation fluid.
 - ✓ All stop-cocks between on-load tap-changer and oil conservator of the on-load tap-changer are open.
1. Switch on transformer.
 2. **NOTICE!** Inrush current impulses can be significantly greater than the transformer rated current and may lead to current paths with asymmetrical or non-sinusoidal curve shapes and, as a result, overload the on-load tap-changer during the diverter switch operation. Only perform tap-change operations - whether under no load or under load conditions - once the inrush current impulse has subsided.

7 Fault elimination

▲ WARNING



Danger of explosion!

Explosive gases under the on-load tap-changer head cover can deflagrate or explode and result in severe injury or death.

- Ensure that there are no ignition sources such as open flames, hot surfaces or sparks (e.g. caused by the build-up of static charge) in the immediate surroundings and that none occur.
- De-energize all auxiliary circuits (for example tap-change supervisory device, pressure relief device, pressure monitoring device) before removing the on-load tap-changer head cover.
- Do not operate any electrical devices during the work (e.g. risk of sparks from impact wrench).

NOTICE

Damage to the on-load tap-changer and transformer!

If the protective relay or other protective devices trip, this can indicate damage to the on-load tap-changer and transformer. The transformer must not be energized without being inspected first.

- Check on-load tap-changer and transformer when protective relay or other protective devices have been tripped.
- Do not use the equipment again until you are sure there is no damage to the on-load tap-changer or transformer.

NOTICE

Damage to motor-drive unit!

Damage to the motor-drive unit due to condensate in protective housing of motor-drive unit.

- Always keep protective housing of the motor-drive unit tightly closed.
- In the event of operation interruptions of more than 2 weeks, connect and operate the heater in the motor-drive unit. If this is not possible, e.g. during transportation, place a sufficient amount of desiccant in the protective housing.

The table below is intended to assist with detecting and, where possible, remedying faults.

For more information, please consult the operating instructions for the protective relay or the relevant protective device.

In the event of faults on the on-load tap-changer and motor-drive unit which cannot be easily corrected on site, or if the protective relay or additional protective devices have been tripped, please inform your authorized MR representative, the transformer manufacturer or contact MR directly.

Maschinenfabrik Reinhausen GmbH
Technical Service
Postfach 12 03 60
93025 Regensburg
Germany
Phone: +49 94140 90-0

Fax: +49 9 41 40 90-7001
 E-mail: service@reinhausen.com
 Internet: www.reinhausen.com

Fault description	Action
Tripping of protective relay	See "Tripping the protective relay and re-commissioning the transformer" Also contact MR.
Tripping of pressure relief device (e.g. MPreC®)	On-load tap-changer and transformer must be checked. Depending on the cause of tripping, take measurements / carry out checks on the transformer. Contact MR to check the on-load tap-changer.
Tripping of pressure monitoring device (e.g. DW 2000)	See "Tripping the pressure monitoring device and putting the transformer back into operation" Also contact MR.
Activation of tap-change supervisory device	The motor-drive unit can no longer be electrically actuated once the tap-change supervisory device has been activated. Manual operation of the motor-drive unit via the hand crank when the transformer is switched on is prohibited. On-load tap-changer and transformer must be checked. Depending on the cause of tripping, take measurements / carry out checks on the transformer. Contact MR to check the on-load tap-changer.
Activation of rupture disk in on-load tap-changer head cover	On-load tap-changer and transformer must be checked. Depending on the cause of tripping, take measurements / carry out checks on the transformer. Contact MR to check the on-load tap-changer.
Tripping of motor protective switch in motor-drive unit	See chapter "Fault elimination" in the operating instructions of the motor-drive unit
Tripping of signaling contact that indicates that the fill level of the insulating fluid has fallen below the minimum in the on-load tap-changer oil conservator	Check pipe system (pipes etc.) and on-load tap-changer head for leaks. Check the fill level and the quality of the insulating fluid in the oil compartment in accordance with the operating instructions for the on-load tap-changer. If the fill level has fallen below the limit values, also contact MR.
On-load tap-changer not changing tap position (sluggishness, Raise keys / Lower keys not working, no audible diverter switch action)	Contact MR.
No change in voltage on the transformer despite change in position on motor-drive unit	Contact MR.
Tap position indicator on motor-drive unit and on-load tap-changer different	Contact MR.
Noises on drive shaft or motor-drive unit when changing tap position	Ensure proper mounting of the drive shaft in accordance with its operating instructions. Check that hose clips and protective covers are seated correctly. Contact MR in the event of noise from the motor-drive unit.
Red message on monitoring unit	If possible read out database and send to MR along with error code.
Warning or tripping of Buchholz relay on transformer	Notify transformer manufacturer.
Deviation from desired value when measuring winding resistance of transformer	Contact transformer manufacturer and, if necessary, MR, and provide measured values.

Fault description	Action
Deviation from desired value during dissolved gas analysis (transformer oil)	Contact transformer manufacturer and, if necessary, MR, and provide measured values.
Deviation from desired value during transformer ratio test	Contact transformer manufacturer and, if necessary, MR, and provide measured values.
Deviation from limit value for insulating fluids	Carry out insulating fluid change, check oil conservator breather of on-load tap-changer.

Table 7: Fault elimination

7.1 Tripping the protective relay and re-commissioning the transformer

⚠ WARNING



Danger of explosion!

Explosive gases in the protective relay can deflagrate or explode and result in severe injury or death.

- > Wait 15 minutes after switching off the transformer before beginning further work on the protective relay so that the gases can dissipate.
- > Ensure that there are no ignition sources such as naked flames, hot surfaces or sparks (e.g. caused by the build-up of static charge) in the immediate surroundings and that none occur.
- > De-energize all auxiliary circuits before beginning work.
- > Do not operate any electrical devices during the work (e.g. risk of sparks from impact wrench).

⚠ WARNING



Danger of death or severe injury!

Danger of severe injury or death if on-load tap-changer and transformer are insufficiently tested.

- > Be sure to contact Maschinenfabrik Reinhausen to check on-load tap-changer and transformer if the protective relay has tripped.
- > Only use the equipment again when you are sure there is no damage to the on-load tap-changer or transformer.

When the circuit breakers have been tripped by the protective relay, proceed as follows:

1. Establish time of tripping.
2. Determine operating position of on-load tap-changer.
3. As a precaution, block the motor-drive unit by tripping the motor protective switch to prevent the on-load tap-changer from being actuated by remote control.
4. Check the on-load tap-changer head cover. If insulating fluid is leaking, close the oil conservator stop valve immediately.
5. Check whether the flap valve of the protective relay is in the OFF or OPERATION position.

7.1.1 Flap valve in OPERATION position

If the flap valve is in the OPERATION position, there may be a fault in the tripping circuit. Check the tripping circuit in this case. If you are not able to clarify why the protective relay tripped, be sure to contact Maschinenfabrik Reinhausen to check the on-load tap-changer.

7.1.2 Flap valve in OFF position



Note that protective relay RS 2004 features an automatic reset mechanism which means that the flap valve does not remain in the OFF position after tripping. If the protective relay RS 2004 has not tripped due to an error in the tripping circuit, also proceed as described below for RS 2004.

If the flap valve is in the OFF position, proceed as follows:

1. Ensure that the transformer is not started up under any circumstances.
2. Contact and inform Maschinenfabrik Reinhausen of the following:
 - » Serial number of protective relay and on-load tap-changer
 - » What was the load of the transformer at the instant of tripping?
 - » Was the on-load tap-changer moved immediately before or during tripping?
 - » Did any other protective devices of the transformer respond at the instant of tripping?
 - » Were switching operations in the network being carried out at the instant of tripping?
 - » Were overvoltages registered at the instant of tripping?
3. Take further action in agreement with Maschinenfabrik Reinhausen.

7.1.3 Re-commissioning the transformer

Once the reason for the protective relay tripping has been established and remedied, you can re-commission the transformer:

1. Check the protective relay [► Section 6.3.4.1, Page 190].
2. Commission the transformer.

7.2 Tripping the pressure monitoring device and putting the transformer back into operation

▲ WARNING



Danger of death or severe injury!

Danger of severe injury or death if on-load tap-changer and transformer are insufficiently tested.

- > Be sure to contact Maschinenfabrik Reinhausen to check on-load tap-changer and transformer after the pressure monitoring device has been tripped.
- > Only use the equipment again when you are sure there is no damage to the on-load tap-changer or transformer.

If the circuit breaker is tripped by the pressure monitoring device, proceed as follows:

1. Establish time of tripping.
2. Determine operating position of on-load tap-changer.
3. As a precaution, block the motor-drive unit by tripping the motor protective switch to prevent the on-load tap-changer from being actuated by remote control.
4. Check the on-load tap-changer head cover. If insulating fluid is leaking, close the oil conservator stop valve immediately.
5. Check whether the pressure monitoring device sensor is in the OFF position or OPERATION position.

7.2.1 Sensor in the OPERATION position

If the sensor is in the OPERATION position, there may be an error in the tripping circuit. Check the tripping circuit in this case. If you are not able to clarify why the pressure monitoring device tripped, be sure to contact Maschinenfabrik Reinhausen to check the on-load tap-changer.

7.2.2 Sensor in the OFF position

Proceed as follows if the sensor is in the OFF position.

1. Ensure that the transformer is not started up under any circumstances.
2. Contact and inform Maschinenfabrik Reinhausen of the following:
 - » What was the load of the transformer at the instant of tripping?
 - » Was there a tap-change operation on the on-load tap-changer immediately before or during the tripping?
 - » Did any other protective devices of the transformer respond at the instant of tripping?
 - » Were switching operations in the network being carried out at the instant of tripping?
 - » Were overvoltages registered at the instant of tripping?
 - » How high is the static pressure on the pressure relief device (height difference between the oil level in the on-load tap-changer oil conservator and the pressure relief device)?
3. Take further action in agreement with Maschinenfabrik Reinhausen.

7.2.3 Re-commissioning the transformer

You can re-commission the transformer once the cause for tripping the pressure monitoring device has been determined and resolved:

1. Ensure that the sensor on the snap-action switch is in the OPERATION position.
2. Commission the transformer.

8 Technical data

The key technical data for the on-load tap-changer is summarized in this chapter.

Further information on the selection of on-load tap-changers in general can be found in the chapters "Tap-changer designation", "Electrical properties" and "Selecting the on-load tap-changer" in the technical data TD61.

8.1 Technical data for on-load tap-changer

8.1.1 On-load tap-changer properties

Electrical data for VACUTAP® VM I

On-load tap-changer	VM I 351	VM I 501	VM I 651	VM I 802	VM I 1002	VM I 1203	VM I 1503
Max. rated through-current I_{rm} [A]	350	500	650	800	1 000	1 200	1 500
Rated short-time current [kA]	4.2	5	6.5	8	10	12	15
Rated duration of short-circuits [s]	3						
Rated peak withstand current [kA]	10.5	12.5	16.25	20	25	30	37.5
Max. rated step voltage U_{irm} [V] ¹⁾	3 300						
Step capacity P_{stN} [kVA]	1 155	1 625	1 625	2 600	2 600	3 500	3 500
Rated frequency [Hz]	50...60						

Table 8: Electrical data for VACUTAP® VM I

On-load tap-changer	VM II 352	VM II 502	VM II 652
Max. rated through-current I_{rm} [A]	350	500	650
Rated short-time current [kA]	4.2	5	6.5
Rated duration of short-circuits [s]	3		
Rated peak withstand current [kA]	10.5	12.5	16.25
Max. rated step voltage U_{irm} [V] ¹⁾	3 300		
Step capacity P_{stN} [kVA]	1 155	1 625	1 625
Rated frequency [Hz]	50...60		

Table 9: Electrical data for VACUTAP® VM II

On-load tap-changer	VM III 350 Y	VM III 500 Y	VM III 650 Y
Max. rated through-current I_{rm} [A]	350	500	650
Rated short-time current [kA]	4.2	5	6.5
Rated duration of short-circuits [s]	3		
Rated peak withstand current [kA]	10.5	12.5	16.25
Max. rated step voltage U_{irm} [V] ¹⁾	3 300		

On-load tap-changer	VM III 350 Y	VM III 500 Y	VM III 650 Y
Step capacity (P_{stN}) [kVA]	1 155	1 625	1 625
Rated frequency [Hz]	50...60		

Table 10: Electrical data for VACUTAP® VM III

¹⁾ The maximum rated step voltage may be exceeded by 10% due to overexcitation of the transformer if the step capacity is limited to its rated value.

Mechanical data for VACUTAP® VM

Number of operating positions	Without change-over selector: maximum 18 With change-over selector: maximum 35 With multiple coarse change-over selector: maximum 107
Number of equipped sectors	1...3
Selector sizes	B, C, D, DE (not with multiple coarse change-over selector)
Dimensions	See dimensional drawings
Weight	
Displacement and oil volume	

Table 11: Mechanical data for VACUTAP® VM I II III

8.1.2 Permissible ambient conditions

Air temperature during operation	-25°C...+50°C
Temperature of the insulating fluid in operation	-25°C...+105°C (up to +115°C when the transformer is in emergency operation)
Transport temperature, storage temperature	-40°C...+50°C
Drying temperatures	See installation and commissioning instructions, "Mounting" chapter
Compressive strength	The on-load tap-changer oil compartment is pressure-resistant to 0.3 bar of continuous differential pressure (test pressure 0.6 bar). The head and cover of the on-load tap-changer and de-energized tap-changer are vacuum-resistant.
Insulating fluid	<ul style="list-style-type: none"> – Unused insulating oils derived from petroleum products¹⁾ in accordance with IEC 60296 and ASTM D3487 (equivalent standards on request) – Unused insulating oils derived from other virgin hydrocarbons in accordance with IEC 60296, or blends of these oils with petroleum products¹⁾ in accordance with IEC 60296, ASTM D3487 or equivalent standards on request – Alternative insulating fluids, such as natural and synthetic esters or silicone oils, on request. <p>¹⁾ Gas-to-liquid oils (GTL oils) are understood in this context to be petroleum products</p>

Table 12: Permissible ambient conditions

8.1.3 Height of the oil conservator

The permissible heights for the oil conservators of the on-load tap-changer and transformer must be observed. These ensure:

- seal integrity of on-load tap-changer oil compartment in relation to surroundings and transformer
- correct function (e.g. switching process) of on-load tap-changer and other pressure-dependent devices

The standard on-load tap-changer model is designed for a maximum oil conservator height H_{max} of **up to 5 m**. To calculate this height, the distance between the maximum oil level in the oil conservator and the top edge of the on-load tap-changer head cover must be determined.

If the height H_{max} of the oil level in the on-load tap-changer's oil conservator is more than 5 m above the on-load tap-changer head cover, this must be stated in the order so that an appropriate product variant can be selected.

For VACUTAP® on-load tap-changers at installation heights H_{NHN} of more than 2,000 m above sea level, the maximum permissible height H_{max} of the oil conservator is increased by the minimum distance H_{max} between the oil level and on-load tap-changer head cover in accordance with section Installation height above sea level.

Difference in height Δh between oil levels in on-load tap-changer and transformer

If the oil conservators for the on-load tap-changer and transformer are in separate locations, the difference in height Δh between the oil levels may be a **maximum of 3 m**.

If the on-load tap-changer and transformer share an oil conservator (with or without divider), this difference is not normally reached. With a shared oil conservator, the difference in height can then be ignored.

8.1.4 Installation height above sea level

VACUTAP® oil-insulated on-load tap-changers with an open oil conservator are released without limitations up to an installation height H_{NHN} of 2,000 m above sea level. Above 2,000 m, a minimum height must be observed for the oil conservator.

The installation height of the oil conservator is determined by the distance H_{\min} between the upper edge of the on-load tap-changer head cover and the oil level in the oil conservator.

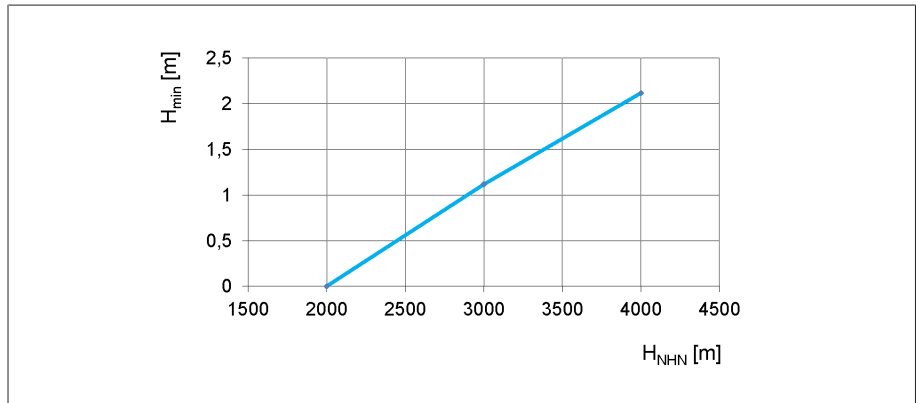

Figure 295: Minimum distance H_{\min} between oil level and on-load tap-changer head cover

H_{\min}	Distance between oil level in the oil conservator and upper edge of the on-load tap-changer head cover.
H_{NHN}	Installation height above sea level

For VACUTAP® on-load tap-changers at installation heights H_{NHN} of more than 2,000 m above sea level, the maximum permissible height of the oil conservator (in accordance with section Height of oil conservator) is increased by this minimum distance H_{\min} between the oil level and on-load tap-changer head cover.

8.2 Technical data for protective relay

The technical data for the protective relay RS 2001 is listed in the following. In accordance with DIN EN 60255-1, operational accuracy = base accuracy

Housing	Outdoor model
Degree of protection	IP66
Relay actuation	Flap valve with aperture
Weight	approx. 3.5 kg
Oil flow speed of available types when tripping (oil temperature 20 °C)	0.65 ± 0.15 m/s 1.20 ± 0.20 m/s 3.00 ± 0.40 m/s 4.80 ± 0.60 m/s

Table 13: General technical data

Tripping circuit

The protective relay can be supplied with either a normally open (NO) or a normally closed (NC) dry-reed magnetic switch (see dimensional drawing supplied). Other contact combinations are available as a special version.

Electrical data for normally closed (NC) dry-reed magnetic switch

Electrical data	
DC switching capacity	1.2 W...200 W
AC switching capacity (50 Hz)	1.2 VA...400 VA
Switching voltage AC/DC	24 V...250 V
Switched current AC/DC	4.8 mA...2 A

Table 14: Electrical data

Switching capacity (switching load on an off)	
Minimum switched current AC/DC (lowest voltage)	50 mA (at 24 V)
Minimum switched current AC/DC (highest voltage)	4.8 mA (at 250 V)
Maximum switched current DC (highest current)	1.6 A (at 125 V with L/R = 40 ms)
Maximum switched current DC (highest voltage)	0.9 A (at 250 V with L/R = 40 ms)
Maximum switched current AC (highest current)	2 A (at 125 V with $\cos \varphi = 0.6$)
Maximum switched current AC (highest voltage)	1.6 A (at 250 V with $\cos \varphi = 0.6$)
Switching operations	1,000 cycles

Table 15: Switching capacity (switching load on an off)

Dielectric strength	
AC dielectric strength between all voltage-carrying connections and the grounded parts	2,500 V, 50 Hz, test duration 1 minute
AC dielectric strength between the opened contacts	2,000 V, 50 Hz, test duration 1 minute

Table 16: Dielectric strength

Electrical data for normally open (NO) dry-reed magnetic switch

Electrical data	
DC switching capacity	1.2 W...250 W
AC switching capacity (50 Hz)	1.2 VA...400 VA
Switching voltage AC/DC	24 V...250 V
Switched current AC/DC	4.8 mA...2 A

Table 17: Electrical data

Switching capacity (switching load on an off)	
Minimum switched current AC/DC (lowest voltage)	50 mA (at 24 V)
Minimum switched current AC/DC (highest voltage)	4.8 mA (at 250 V)
Maximum switched current DC (highest current)	2 A (at 125 V with L/R = 40 ms)
Maximum switched current DC (highest voltage)	1 A (at 250 V with L/R = 40 ms)
Maximum switched current AC (highest current)	2 A (at 125 V with $\cos \varphi = 0.6$)
Maximum switched current AC (highest voltage)	1.6 A (at 250 V with $\cos \varphi = 0.6$)
Switching operations	1,000 cycles

Table 18: Switching capacity (switching load on an off)

Dielectric strength	
AC dielectric strength between all voltage-carrying connections and the grounded parts	2,500 V, 50 Hz, test duration 1 minute
AC dielectric strength between the opened contacts	2,000 V, 50 Hz, test duration 1 minute

Table 19: Dielectric strength

Ambient conditions

Ambient temperature Ta	-40°C...+50°C
Oil temperature	<130 °C
Air pressure	Corresponds to 0 m...4,000 m above sea level

Table 20: Ambient conditions

8.3 Special models of protective relay

8.3.1 Protective relay with CO change-over contact as tripping switch

The protective relay can be supplied with a dry-reed magnetic switch, CO change-over (variant 3) (see dimensional drawing supplied).

Electrical data for CO change-over dry-reed magnetic switch

Electrical data	
DC switching capacity	1.2 W...150 W
AC switching capacity (50 Hz)	1.2 VA...200 VA
Switching voltage AC/DC	24 V...250 V
Switched current AC/DC	4.8 mA...1 A

Table 21: Electrical data

Switching capacity (switching load on an off)	
Minimum switched current AC/DC (lowest voltage)	50 mA (at 24 V)
Minimum switched current AC/DC (highest voltage)	4.8 mA (at 250 V)
Maximum switched current DC (highest current)	1.0 A (at 150 V with L/R = 40 ms)
Maximum switched current DC (highest voltage)	0.6 A (at 250 V with L/R = 40 ms)
Maximum switched current AC (highest current)	1 A (at 200 V with $\cos \varphi = 0.6$)
Maximum switched current AC (highest voltage)	0.8 A (at 250 V with $\cos \varphi = 0.6$)
Switching operations	1,000 cycles

Table 22: Switching capacity (switching load on an off)

Dielectric strength	
AC dielectric strength between all voltage-carrying connections and the grounded parts	2,500 V, 50 Hz, test duration 1 minute
AC dielectric strength between the opened contacts	1,150 V, 50 Hz, test duration 1 minute

Table 23: Dielectric strength

8.3.2 Protective relay with several dry-reed magnetic switches

The protective relay can be supplied with several independent dry-reed magnetic switches. These can be designed as normally open (NO) or normally closed (NC) contacts and are electrically isolated (see dimensional drawing supplied).

Electrical data for normally open (NO) and normally closed (NC) dry-reed magnetic switch

8.4 Technical data for pressure monitoring device

General technical data

Setup	Outdoor model
Ambient temperature	-40 °C...+80 °C (mechanical)
Cable gland	M25x1.5
Degree of protection	IP55 in accordance with IEC 60529 (enclosed device)
Relay actuation	Corrugated tubing with counter-pressure spring
Oil temperature	-40 °C...+100 °C
Weight	approx. 1.2 kg
Equipment	For standard insulating fluids (IEC60296 and IEC60422)
Sealing material (oil – air)	VITON
Permitted pressure range (absolute pressure)	1 bar...6 bar, vacuum not permitted
Upper switching pressure	3.8 ± 0.2 bar (trip pressure)
Lower switching pressure	2,8 ± 0,2 bar
Snap-action switch	
Connection terminals	Lead connection: 1 or 2 leads per terminal (Ø 0.75...2.5 mm ²)
Contacts	1xNO (normally open), 1xNC (normally closed)
Utilization category	IEC 60947-5-1: AC 15: 230 V/1 A DC 13: 60 V/0.5 A
Maximum continuous current	10 A
Rated insulation voltage	AC: 2.5 kV/min

Table 24: General technical data

8.5 Limit values for dielectric strength and water content of insulating fluids

Limit values for insulating fluids in accordance with IEC 60296	U_d	H ₂ O
When commissioning the transformer for the first time	> 60 kV/2.5 mm	< 12 ppm
During operation	> 30 kV/2.5 mm	< 30 ppm
After maintenance	> 50 kV/2.5 mm	< 15 ppm

Table 25: Limit values for insulating fluids in accordance with IEC 60296, dielectric strength measured in accordance with IEC 60156, water content measured in accordance with IEC 60814

Limit values for natural esters in accordance with IEC 62770	U_d	H ₂ O
When commissioning the transformer for the first time	> 60 kV/2.5 mm	≤ 100 ppm
During operation	> 30 kV/2.5 mm	≤ 200 ppm
After maintenance	> 50 kV/2.5 mm	≤ 100 ppm

Table 26: Limit values for natural esters in accordance with IEC 62770, dielectric strength measured in accordance with IEC 60156, water content measured in accordance with IEC 60814

Limit values for synthetic esters in accordance with IEC 61099	U_d	H ₂ O
When commissioning the transformer for the first time	> 60 kV/2.5 mm	≤ 100 ppm
During operation	> 30 kV/2.5 mm	≤ 400 ppm
After maintenance	> 50 kV/2.5 mm	≤ 150 ppm

Table 27: Limit values for synthetic esters in accordance with IEC 61099, dielectric strength measured in accordance with IEC 60156, water content measured in accordance with IEC 60814

8.6 On-load tap-changer for Y connection with open neutral point

If on-load tap-changers have an open neutral point, **only current transformers** may be connected to the open neutral point. Otherwise impermissible overvoltages arise at the neutral point.



Reactors must not be connected.

Connection of three oil vessel outputs (= open neutral point)	VACUTAP VM III 300/350/500/650 Y	
Current transformer connection and neutral point formation outside on-load tap-changer	A) Test voltages permitted between the oil vessel output contacts	
	– Rated lightning impulse withstand voltage	< 140 kV (1.2/50 μ S) ¹⁾
	– Rated short-duration power frequency withstand voltage	1 kV (50 Hz, 1 min)
	B) Permissible maximum operating voltage between oil vessel output contacts	1 kV (50...60 Hz)
¹⁾ varistor response voltage at 1.2/50 μ s lightning impulse: > 1.4 kV, residual voltage at 1000 A (8/20 μ s) peak withstand current: < 3 kV, maximum permissible energy load of the varistor < 100 J		

Table 28: Permissible test voltages and operating voltages for VACUTAP® VM III 300/350/500/650 Y

9 Drawings

© MASCHINENFABRIK REINHAUSEN GMBH 2018
 Weitergabe sowie Vervielfältigung dieses Dokuments, Verwertung und Mitteilung seines Inhaltes sind verboten, soweit nicht ausdrücklich gestattet.
 Zuwiderhandlungen verpflichten zu Schadensersatz. Alle Rechte für den Fall der Patent-, Gebrauchsmuster- oder Designeintragung vorbehalten.

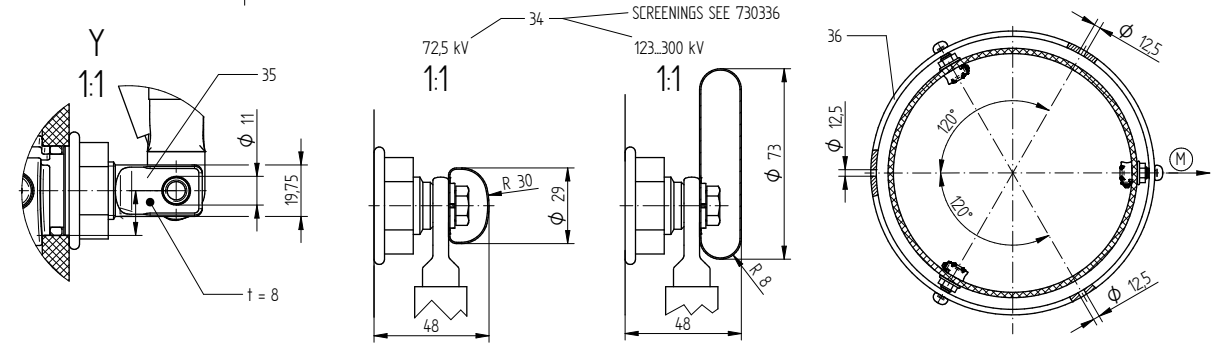
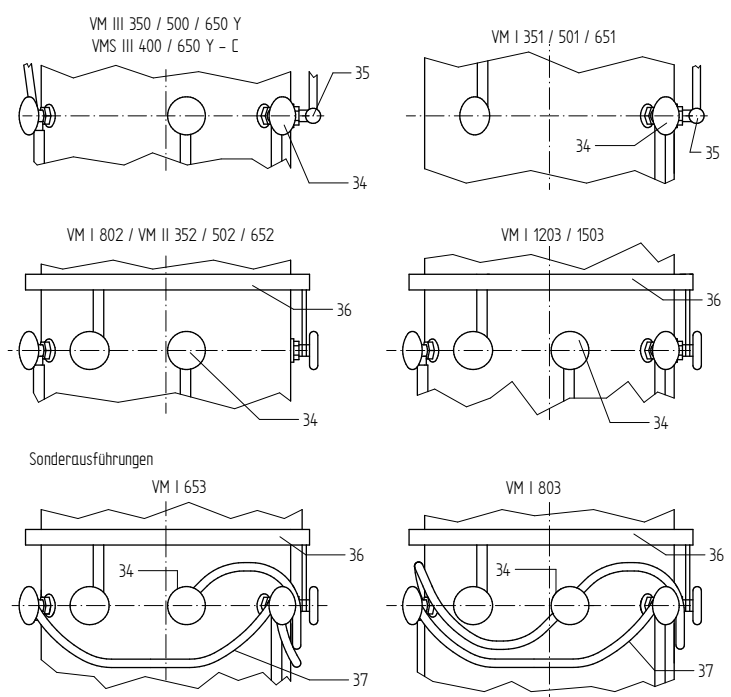
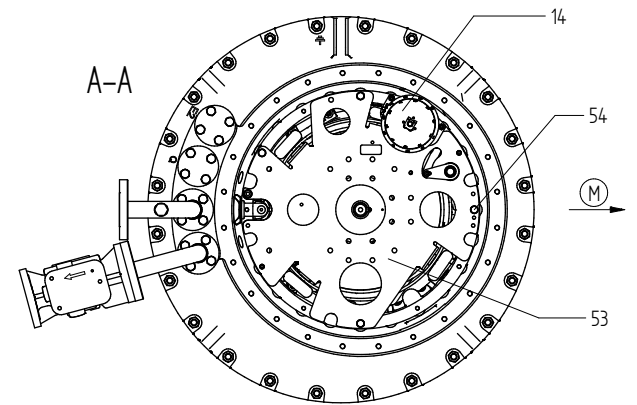
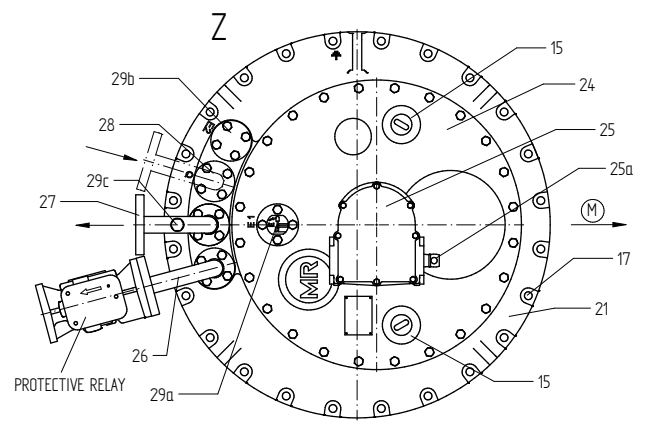
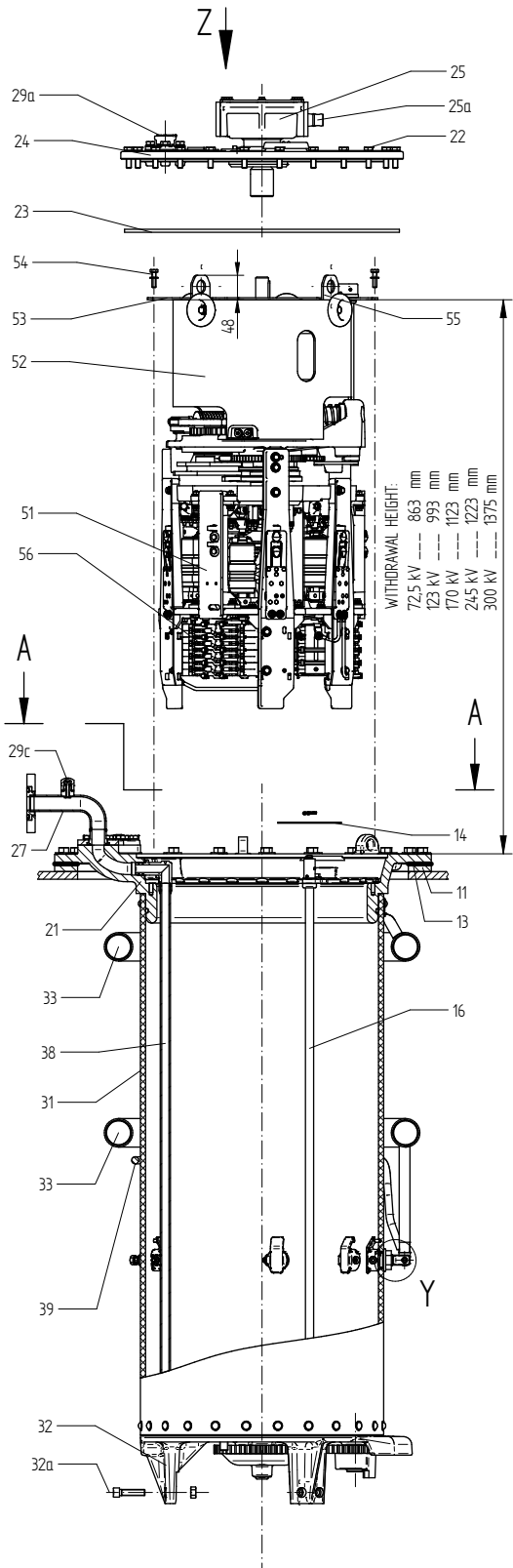

Datum	Name	Dokumentnummer
13.07.2018	BUTERUS	SED 2317110 001 03
Gez. bepr.	WILHELM	Änderungsnummer
16.07.2018	PRODASTSCHUK	1086956
Norm.		15

Maßangaben
 in mm, soweit
 nicht anders
 angegeben



ON-LOAD TAP-CHANGER VACUTAP® VM®, VMS®-C
 M-SELECTOR SIZE B/C/D/DE (CENTRIC DRIVE)
 INSTALLATION DRAWING

Serialnummer	
Materialnummer	Blatt
7462303E	1/2

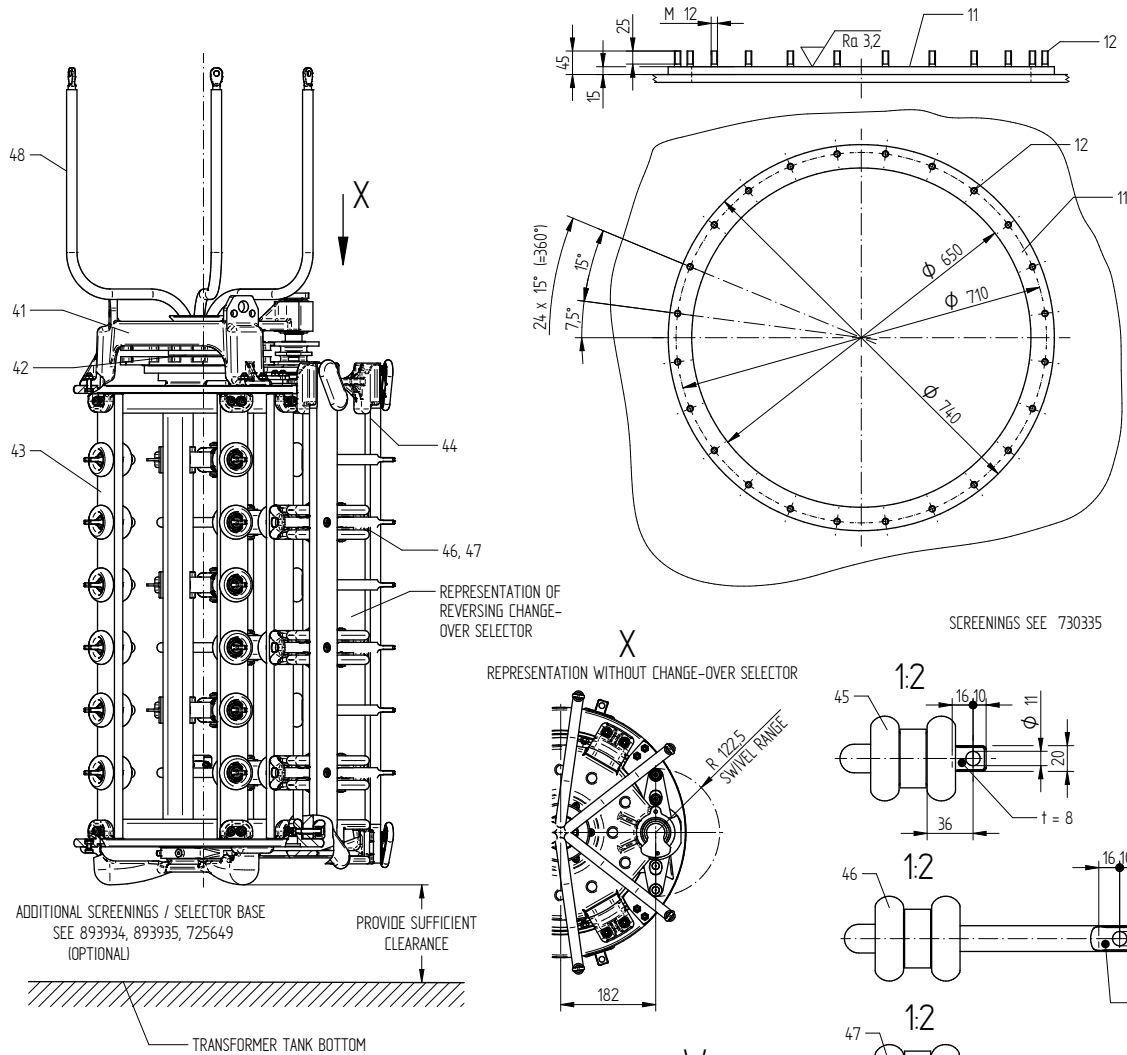

- 11 MOUNTING FLANGE ON TRANSFORMER COVER
- 12 FIXING BOLT M12
- 13 ON-LOAD TAP-CHANGER HEAD GASKET
- 14 TAP POSITION INDICATOR
- 15 INSPECTION WINDOW
- 16 DRIVE SHAFT FOR TAP POSITION INDICATOR
- 17 THROUGH-HOLES 15mm IN DIAMETER

- 21 ON-LOAD TAP-CHANGER HEAD
- 22 COVER BOLT
- 23 COVER GASKET
- 24 ON-LOAD TAP-CHANGER HEAD COVER
- 25 CENTRIC GEAR UNIT WITH DRIVE SHAFT 25a
- 26 PIPE CONNECTING R FOR PROTECTIVE RELAY
- 27 PIPE CONNECTING S FOR SUCTION PIPE
- 28 PIPE CONNECTING Q FOR OIL RETURN PIPE (WITH OIL FILTER ONLY)
- 29a AIR-VENT VALVE OF ON-LOAD TAP-CHANGER HEAD COVER
- 29b BLEEDING FACILITY FOR TRANSFORMER OIL COMPARTMENT
- 29c VENT SCREW FOR SUCTION PIPE

(M) → DRIVE SIDE OF SELECTOR

** NOT WITH MULTIPLE COARSE CHANGE-OVER SELECTOR

- 31 DIVERTER SWITCH OIL COMPARTMENT
- 32 OIL COMPARTMENT BASE WITH SUPPORTING BOLT 32a
- 33 SCREENING RINGS (WITH Um = 170 kV; 245 kV; 300 kV ONLY)
- 34 OIL COMPARTMENT CONNECTION TERMINAL
- 35 TERMINAL:
VM III 350/500/650, VMS III 400/650: NEUTRAL CONNECTION
VM I 351/501/651: TAKE-OFF TERMINAL
- 36 ON-LOAD TAP-CHANGER TAKE-OFF RING (ONLY VM I 802/803/1203/1503)
- 37 CONNECTING LEAD (ONLY VM I 653/803)
- 38 SUCTION PIPE
- 39 SCREENING RING (WITH Um = 123 kV ONLY)
- 41 SELECTOR SUSPENSION
- 42 SELECTOR GEAR
- 43 TAP SELECTOR
- 44 CHANGE-OVER SELECTOR
- 45 SELECTOR CONNECTION CONTACT (SEE CORRESPONDING DIMENSION DRAWING)
- 46 CHANGE-OVER SELECTOR CONNECTION CONTACT "K" OR "O" **
- 47 CHANGE-OVER SELECTOR CONNECTION CONTACT "+", "—" OR "—" **
- 48 SELECTOR CONNECTING LEAD

- 51 DIVERTER SWITCH INSERT
- 52 SUPPORTING CYLINDER
- 53 BASE PLATE
- 54 FIXING BOLT
- 55 EYEBOLT WITH THROUGH-HOLE 25 mm IN DIAMETER
- 56 TRANSITION RESISTORS

Datum	Name	Dokumentnummer
13.07.2018	BUTERUS	SED 2317110 001 03
Gez. bepr.	WILHELM	Änderungsnummer
16.07.2018	PRODASTSCHUK	1086956
Norm.		15

Maßangaben in mm, soweit nicht anders angegeben



ON-LOAD TAP-CHANGER VACUTAP® VM®, VMS®-C
M-SELECTOR SIZE B/C/D/DE (CENTRIC DRIVE)
INSTALLATION DRAWING

Serialnummer	
Materialnummer	Blatt
7462303E	2/2

© MASCHINENFABRIK REINHAUSEN GMBH 2018
 THE REPRODUCTION, DISTRIBUTION AND UTILIZATION OF THIS DOCUMENT AS WELL AS THE COMMUNICATION OF ITS CONTENTS TO OTHERS WITHOUT EXPRESS AUTHORIZATION IS PROHIBITED. OFFENDERS WILL BE HELD LIABLE FOR THE PAYMENT OF DAMAGES. ALL RIGHTS RESERVED IN THE EVENT OF THE GRANT OF A PATENT, UTILITY MODEL OR DESIGN.

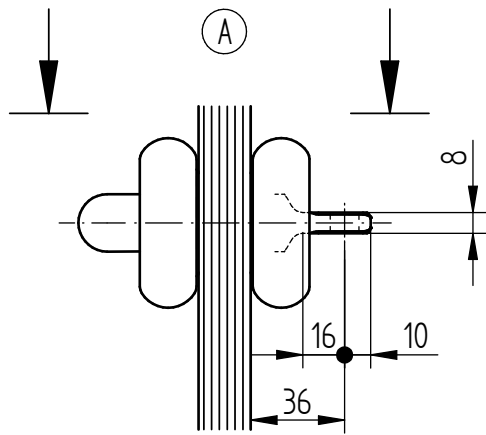

THROUGH-HOLE VERTICAL

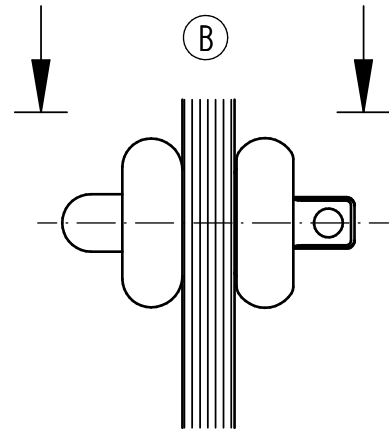
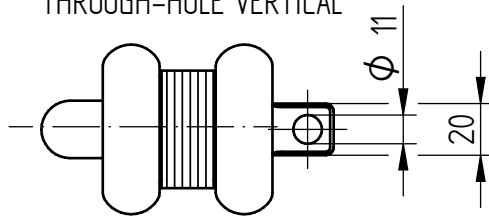

THROUGH-HOLE HORIZONTAL

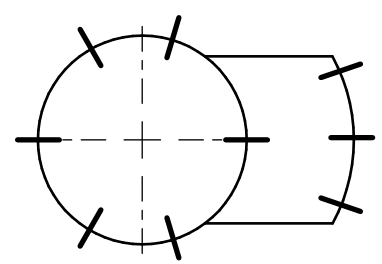
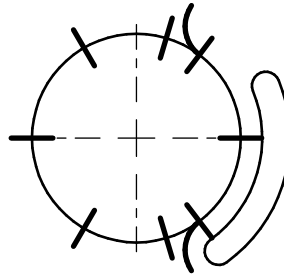
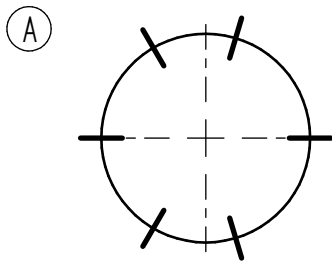
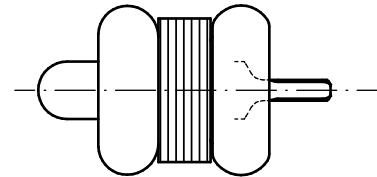

M III 350 / 500 / 600Y - 0
 VM III 350 / 500 / 650Y - 0
 VMS III 400 / 650Y - C - 0
 M II 352 / 502 / 602 - 0
 VM II 352 / 502 / 652 - 0
 M I 351 / 501 / 601 - 0
 VM I 351 / 501 / 651 - 0

M III 350 / 500 / 600Y - W
 VM III 350 / 500 / 650Y - W
 VMS III 400 / 650Y - C - W
 M II 352 / 502 / 602 - W
 VM II 352 / 502 / 652 - W
 M I 351 / 501 / 601 - W
 VM I 351 / 501 / 651 - W

M III 350 / 500 / 600Y - G
 VM III 350 / 500 / 650Y - G
 VMS III 400 / 650Y - C - G
 M II 352 / 502 / 602 - G
 VM II 352 / 502 / 652 - G
 M I 351 / 501 / 601 - G
 VM I 351 / 501 / 651 - G

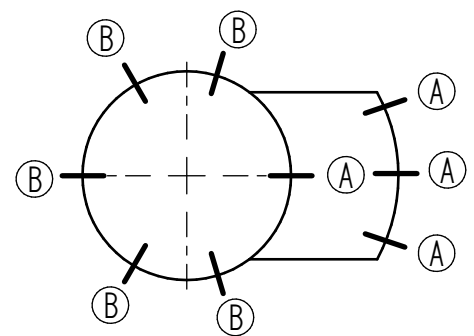
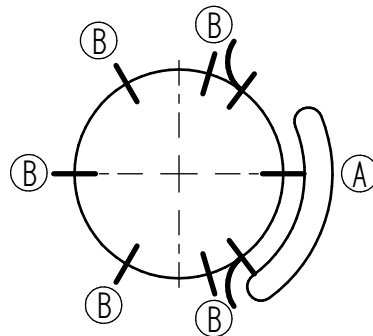
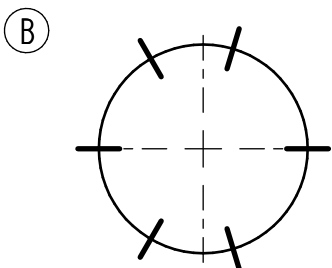

M I 802 - 0
 VM I 802 - 0
 VM I 1002 - 0
 M I 1203 / 1503 - 0
 VM I 1203 / 1503 - 0

M I 802 - W
 VM I 802 - W
 VM I 1002 - W
 M I 1203 / 1503 - W
 VM I 1203 / 1503 - W

M I 802 - G
 VM I 802 - G
 VM I 1002 - G
 M I 1203 / 1503 - G
 VM I 1203 / 1503 - G

(A) + (B)

DATE	NAME	DOCUMENT NO.
13.07.2018	BUJERUS	SED 1706800 000 03
16.07.2018	WILHELM	CHANGE NO.
16.07.2018	PRODASTSCHUK	1086956
SCALE		1:2

DIMENSION
IN mm
EXCEPT AS
NOTED



OLTC OILTAP® M / VACUTAP® VM®, VMS®-C
 INSTALLATION POSITION OF SELECTOR CONNECTION CONTACTS
 M-SELECTOR SIZE B/C/D/E

SERIAL NUMBER

MATERIAL NUMBER
890477BE

SHEET
1 / 1

© MASCHINENFABRIK REINHAUSEN GMBH 2018
 THE REPRODUCTION, DISTRIBUTION AND UTILIZATION OF THIS DOCUMENT AS WELL AS THE COMMUNICATION OF ITS CONTENTS TO OTHERS WITHOUT EXPRESS AUTHORIZATION IS
 PROHIBITED. OFFENDERS WILL BE HELD LIABLE FOR THE PAYMENT OF DAMAGES. ALL RIGHTS RESERVED IN THE EVENT OF A PATENT, UTILITY MODEL OR DESIGN.

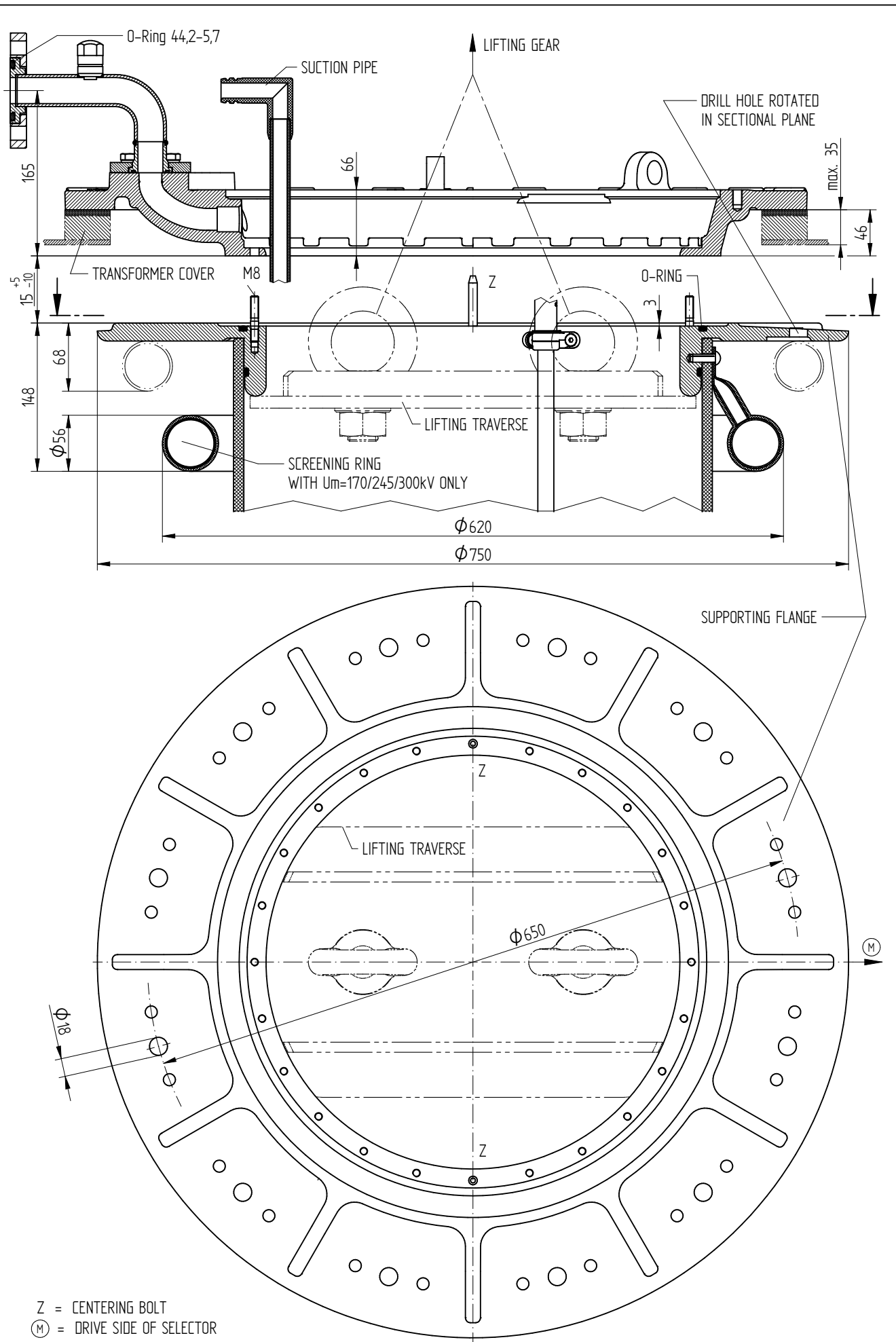

Z = CENTERING BOLT
 (M) = DRIVE SIDE OF SELECTOR

DATE	NAME	DOCUMENT NO.
13.07.2018	BUTERUS	SED 1507378 000 04
16.07.2018	WILHELM	CHANGE NO. SCALE
16.07.2018	PRODASTSCHUK	1086956 1:2,5

DIMENSION
 IN mm
 EXCEPT AS
 NOTED



ON-LOAD TAP-CHANGER
 OILTAP® M, R, RM, MS AND VACUTAP® VM®, VMS®
 SPECIAL DESIGN BELL-TYPE TANK INSTALLATION FOR Um UP TO 300 kV

SERIAL NUMBER	
MATERIAL NUMBER	SHEET
896762CE	1/1

Weitergabe sowie Vervielfältigung dieses Dokuments, Verwertung und Mitteilung seines Inhaltes sind verboten, soweit nicht ausdrücklich gestattet.
Zuwendungen verpflichten zu Schadenersatz. Alle Rechte für den Fall der Patent-, Gebrauchsmuster- oder Geschmacksustereintragung vorbehalten.

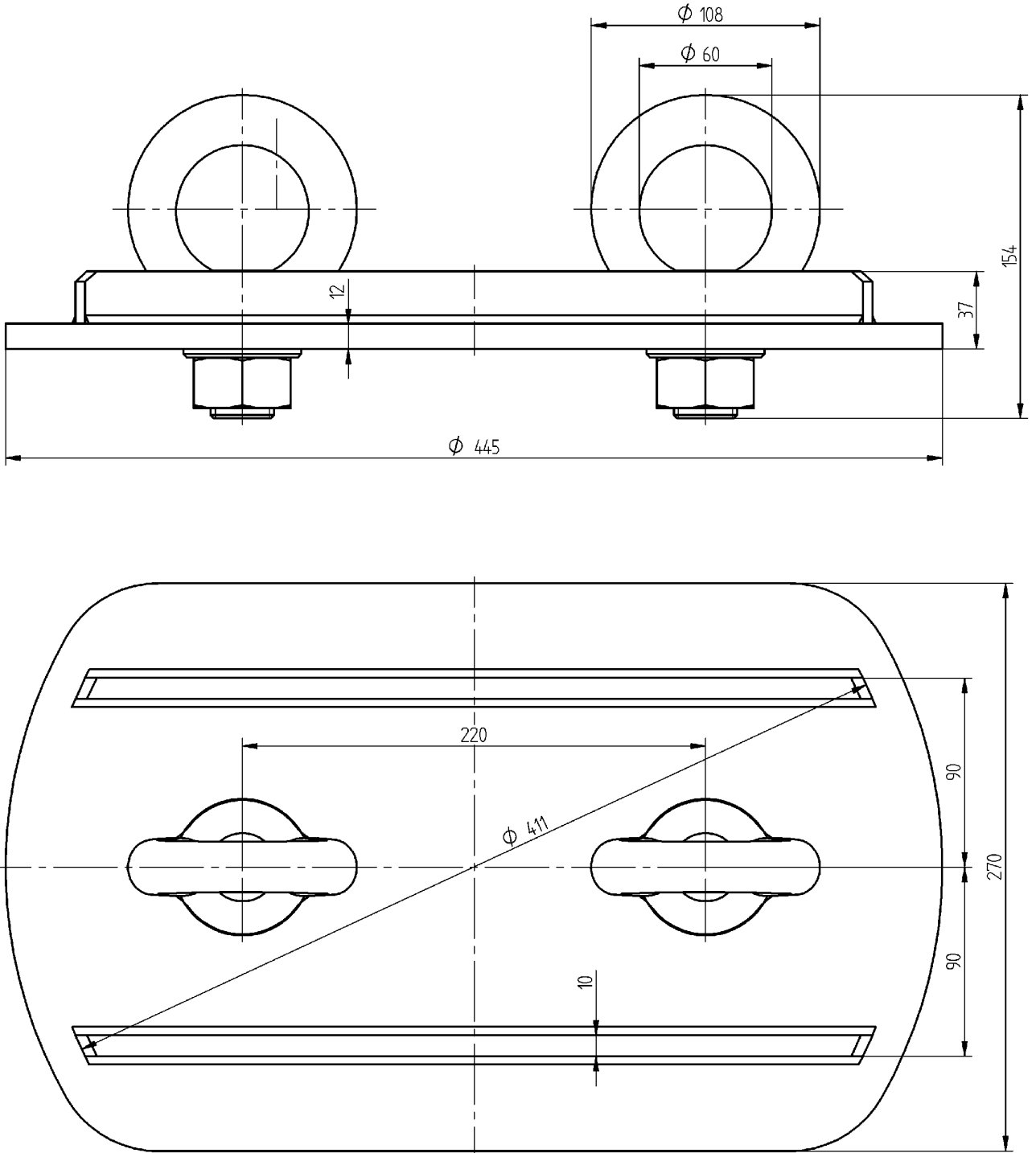

13,5 kg

gez.	PAG	21.06.11	
gepr.	SKL		
SE	1036752	21.06.11	PAG
4E	1001149	22.03.05	JPI
An. in	And.-Nr.	Tag	Name



ON-LOAD TAP CHANGER TYPE M, R, VM, VV
GLK-LIFTING TRAVERSE M,R without LUE

8901805E

© MASCHINENFABRIK REINHAUSEN GMBH 2018
 THE REPRODUCTION, DISTRIBUTION AND UTILIZATION OF THIS DOCUMENT AS WELL AS THE COMMUNICATION OF ITS CONTENTS TO OTHERS WITHOUT EXPRESS AUTHORIZATION IS PROHIBITED. OFFENDERS WILL BE HELD LIABLE FOR THE PAYMENT OF DAMAGES. ALL RIGHTS RESERVED IN THE EVENT OF THE GRANT OF A PATENT, UTILITY MODEL OR DESIGN.

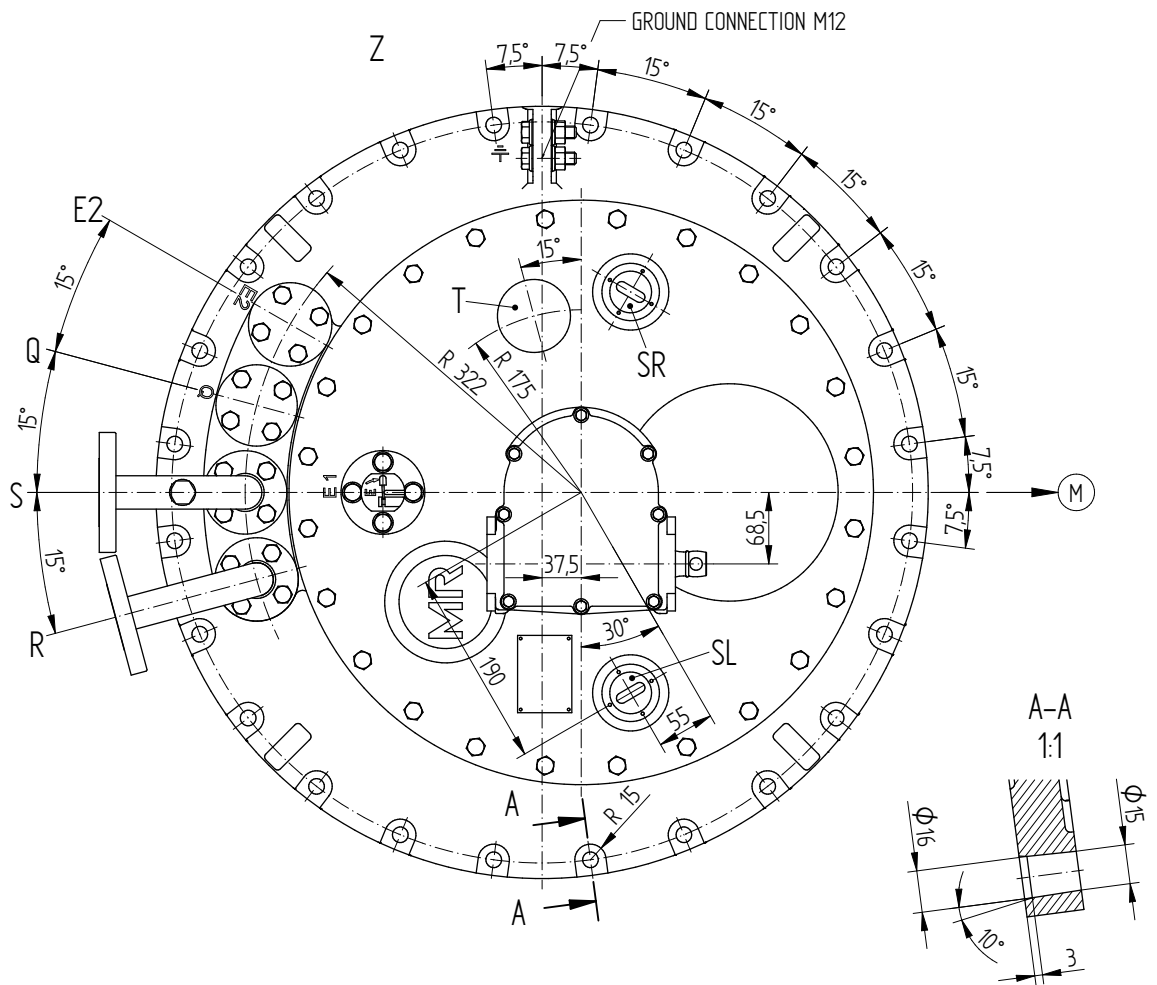
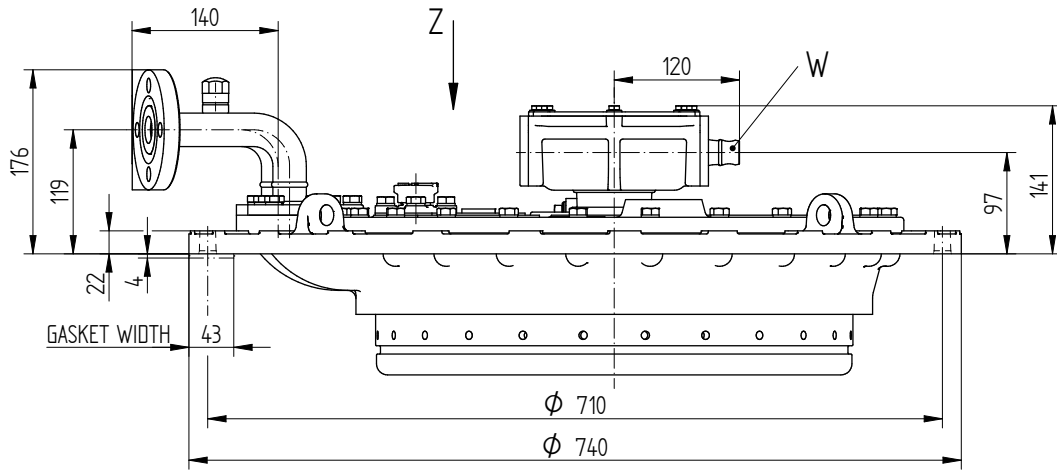

E1 = BLEEDING FACILITY FOR ON-LOAD TAP-CHANGER HEAD

E2 = BLEEDING FACILITY FOR SPACE UNDER THE HEAD OUTSIDE

THE TAP-CHANGER OIL COMPARTMENT (SAME PIPE CONNECTION AS R, S, Q OR BLEEDER SCREW CAN BE USED)

Q = CONNECTION FOR OIL RETURN PIPE OR TAP-CHANGE SUPERVISORY CONTROL

S = CONNECTION FOR SUCTION PIPE

R = CONNECTION FOR PROTECTIVE RELAY (EXCHANGEABLE WITH CONNECTION Q)

T = THERMOMETER BAG / TEMPERATURE SENSOR (OPTIONALLY)

SR = INSPECTION WINDOW, RIGHT

SL = INSPECTION WINDOW, LEFT

W = DRIVE SHAFT

(M) DRIVE SIDE OF SELECTOR

CONNECTIONS SWIVELING
 DIMENSIONS AND SELECTION 899496: / 899497.

DATE	NAME	DOCUMENT NO.
DFTR. 11.07.2018	BUTERUS	SED 1661272 001 04
CHKD. 16.07.2018	WILHELM	SCALE 1:2,5
STAND. 16.07.2018	PRODASTSCHUK	CHANGE NO. 1086956

DIMENSION
 IN mm
 EXCEPT AS
 NOTED



ON-LOAD TAP-CHANGER
 OILTAP® M, MS, R, RM AND VACUTAP® VR®, VM®, VMS®
 ON-LOAD TAP-CHANGER HEAD, CENTRIC DRIVE

SERIAL NUMBER

MATERIAL NUMBER
 893899FE

SHEET
 1/1

© MASCHINENFABRIK REINHAUSEN GMBH 2016
 THE REPRODUCTION, DISTRIBUTION AND UTILIZATION OF THIS DOCUMENT AS WELL AS THE COMMUNICATION OF ITS CONTENTS TO OTHERS WITHOUT EXPRESS AUTHORIZATION IS PROHIBITED. OFFENDERS WILL BE HELD LIABLE FOR THE PAYMENT OF DAMAGES. ALL RIGHTS RESERVED IN THE EVENT OF A PATENT, UTILITY MODEL OR DESIGN.

PIPE CONNECTION WITH TAP-CHANGE SUPERVISORY CONTROL BUSHING WITHOUT OIL FILTER UNIT

NOTICE!
 THE VENT SCREW ② OF THE MOUNTED HOUSING ① HAS TO BE ON THE TOP

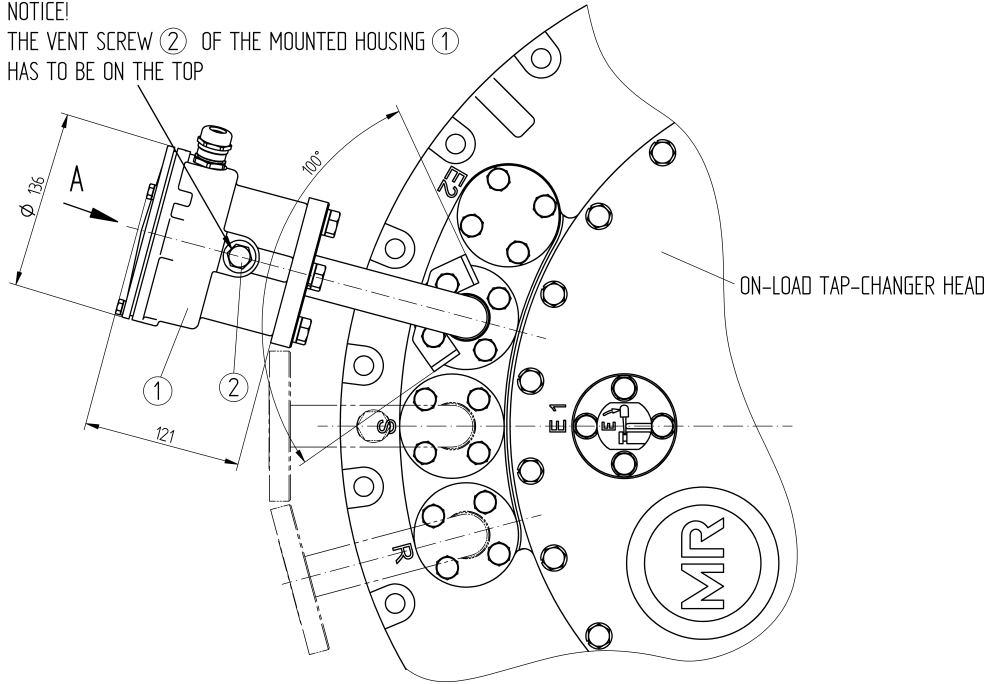

A ↷ 1:1

REPRESENTED WITHOUT COVER

M20x1.5
 CLAMPING RANGE FOR CONNECTION CABLE:
 EXTERNAL DIAMETER: 7 - 13 mm

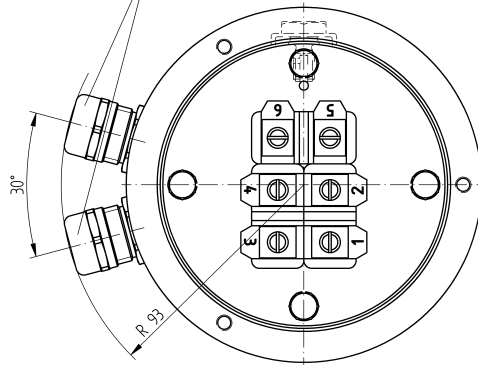

CONNECTION TERMINALS FOR TAP-CHANGE
 SUPERVISORY CONTROL

WIRING SEE CONNECTION DIAGRAM OF THE
 MOTOR-DRIVE UNIT

FUNCTION DIAGRAM FOR TAP-CHANGE SUPERVISORY
 CONTROL SEE MOTOR-DRIVE CONNECTION DIAGRAM

RATED CONTINUOUS CURRENT: 2A
 RATED VOLTAGE DC/AC (50HZ): 24V ... 250V
 DIELECTRIC STRENGTH: 1150V / 50HZ / 1 MIN.

DIELECTRIC TEST OF ALL VOLTAGE CARRYING
 TERMINALS TO GROUND:
 2000V AC , 50HZ , TEST-DURATION 1 MIN.

DATE	NAME	DOCUMENT NO.
03.11.2016	RAEDLINGER	SED 2425358 001 02
04.11.2016	NERRETER	CHANGE NO.
04.11.2016	PRODASTSCHUK	1078202
DFTR.	SCALE	1:2
CHKD.		
STAND.		

DIMENSION
 IN mm
 EXCEPT AS
 NOTED



ON-LOAD TAP-CHANGER VACUTAP® VM, VR
PIPE CONNECTION WITH TAP-CHANGE SUPERVISORY CONTROL

SERIAL NUMBER

MATERIAL NUMBER
 7661612E

SHEET
 1/1

The copying, distribution and utilization of this document as well as the communication of its contents to others without expressed authorization is prohibited. Offenders will be held liable for the payment of damages. All rights reserved in the event of the grant of a patent, utility model or ornamental design registration.

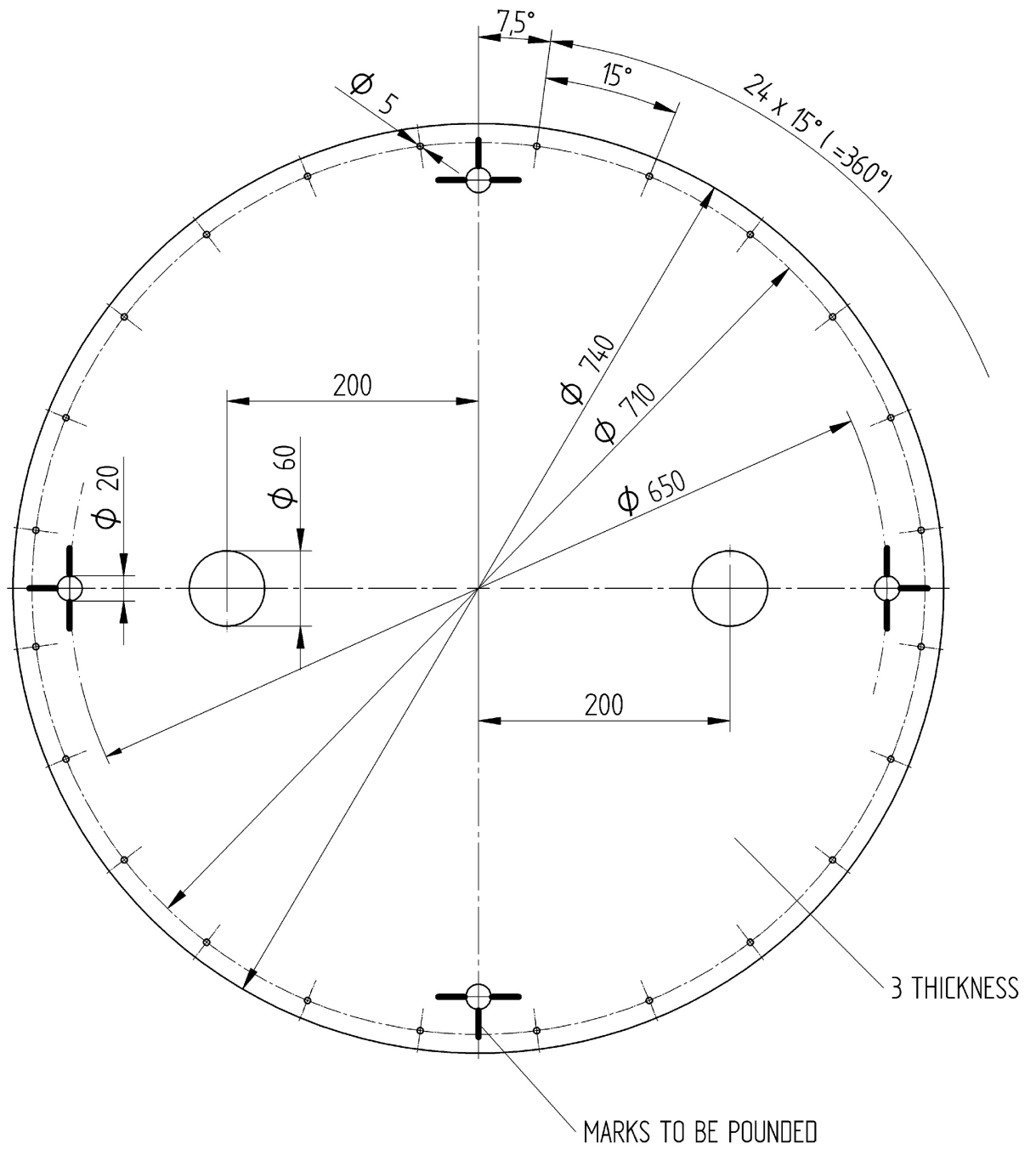

gep.	BHA	08.09.04	Meier
01	016623	1107108	BM
00	052749	08/05/04	BAK
			Fig.
			Name
			Part No.



ON-LOAD TAP-CHANGER VACUTAP[®], OILTAP[®]
 DRILLING TEMPLATE FOR
 ON-LOAD TAP-CHANGER HEAD

8901838E

© MASCHINENFABRIK REINHAUSEN GMBH 2014
 THE REPRODUCTION, DISTRIBUTION AND UTILIZATION OF THIS DOCUMENT AS WELL AS THE COMMUNICATION OF ITS CONTENTS TO OTHERS WITHOUT EXPRESS AUTHORIZATION IS PROHIBITED. OFFENDERS WILL BE HELD LIABLE FOR THE PAYMENT OF DAMAGES. ALL RIGHTS RESERVED IN THE EVENT OF THE GRANT OF A PATENT, UTILITY MODEL OR DESIGN.

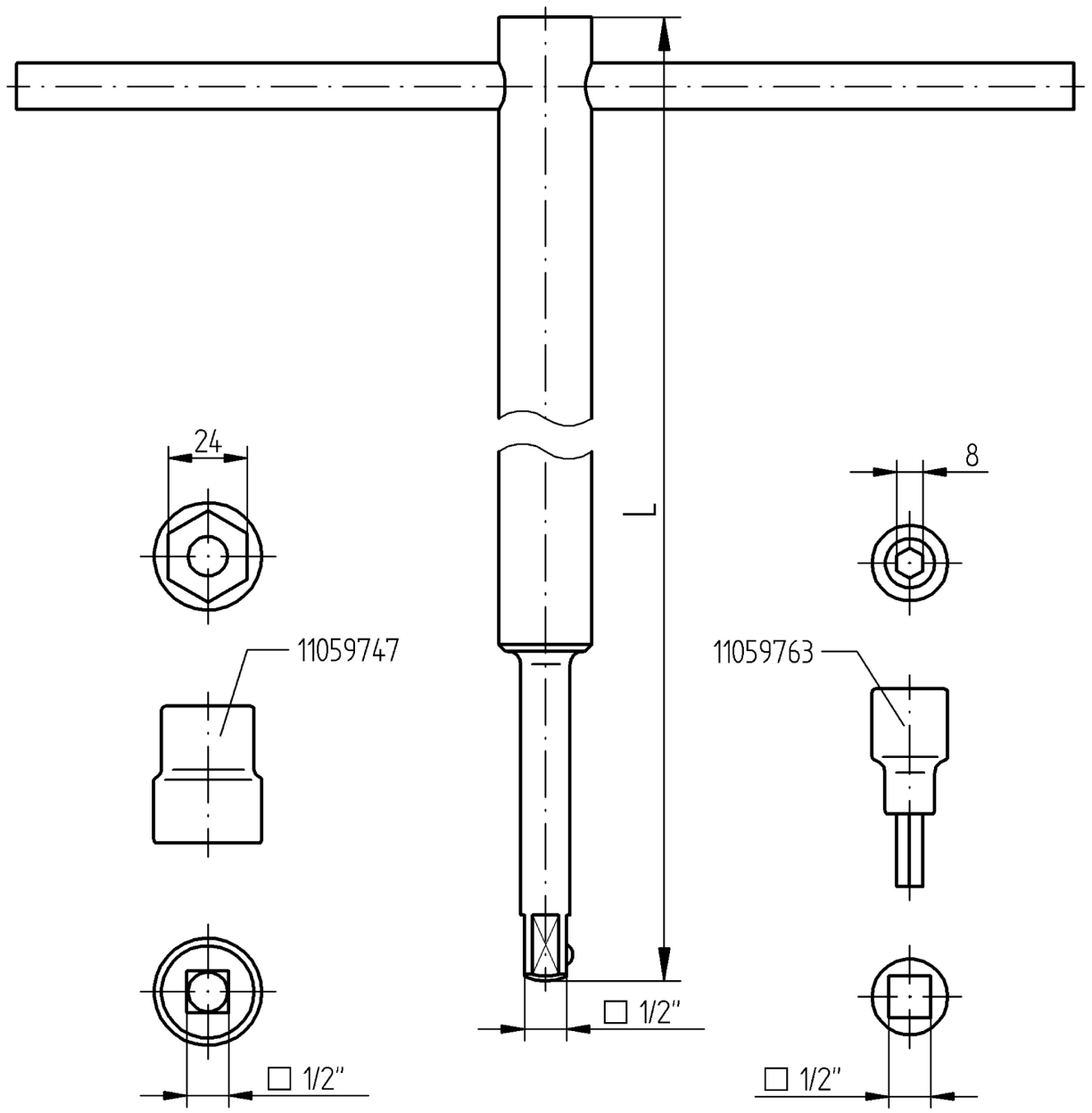

DATE	NAME	DOCUMENT NO.
28.04.2014	RAEDLINGER	SED 1964530 000 01
17.06.2014	HAUER	CHANGE NO.
17.06.2014	PRODASTSCHUK	1057233
		SCALE
		1:2

SOCKET WRENCH	ITEM NO. 014820: L = 1350 mm	ITEM NO. 017660: L = 1860 mm
TO BE USED FOR ON-LOAD TAP-CHANGERS	TYPE M (EXEPT M Δ) TYPE MS TYPE VM®	TYPE M III 350 Δ / 600 Δ TYPE T TYPE R TYPE RM TYPE G TYPE VR®

DIMENSION IN mm EXCEPT AS NOTED



ON-LOAD TAP-CHANGER
 OILTAP® MS, M, T, RM, R, G AND VACUTAP® VR®, VM®
 SOCKET WRENCH FOR KEROSENE DRAIN PLUG

SERIAL NUMBER	
MATERIAL NUMBER 890182BE	SHEET 1/1

© MASCHINENFABRIK REINHAUSEN GMBH 2016

Weitergabe sowie Vervielfältigung dieses Dokuments, Verwertung und Mitteilung seines Inhaltes sind verboten, soweit nicht ausdrücklich gestattet. Zuwiderhandlungen verpflichten zu Schadensersatz. Alle Rechte für den Fall der Patent-, Gebrauchsmuster- oder Geschmacksustereintragung vorbehalten.

Datum	01.06.2016	Name	BRANDL	Dokumentnummer	SED 2127250 000 02
Gez.	01.06.2016	Huberth	HUBERTH	Änderungsnummer	Maßstab
Norm.	01.06.2016	Prodastrichuk	PRODASTRICHUK	1074942	1:2

Maßangaben
in mm, soweit
nicht anders
angegeben



Zubehör Stufenschalter
Winkeltrieb CD6400BEVEL GEAR CD6400
Maßzeichnung

Serialnummer

Materialnummer
8929167M

Blatt
1 / 1

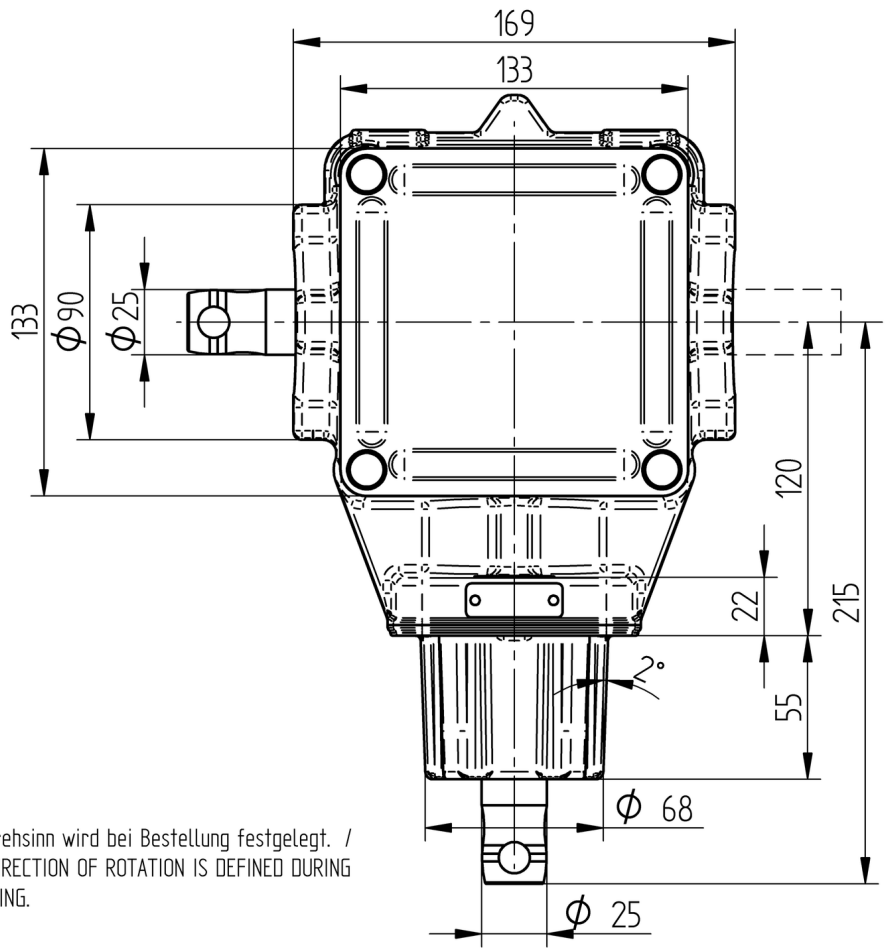

Der Drehsinn wird bei Bestellung festgelegt. /
THE DIRECTION OF ROTATION IS DEFINED DURING
ORDERING.

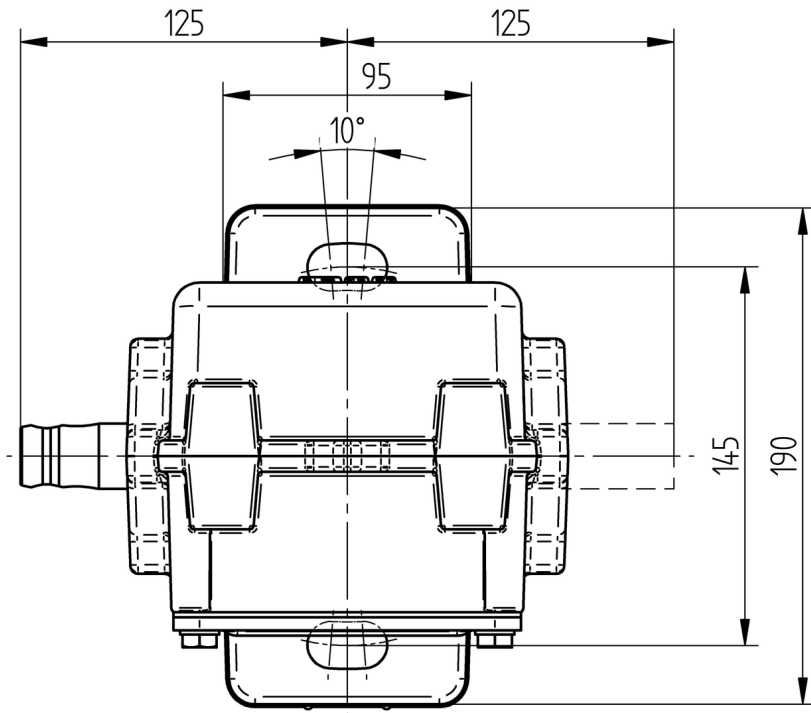

Maschinenfabrik Reinhausen GmbH

Falkensteinstrasse 8
93059 Regensburg
Germany
+49 941 4090-0
info@reinhausen.com
[reinhausen.com](https://www.reinhausen.com)

Please note:
The data in our publications may differ from the data of the devices delivered.
We reserve the right to make changes without notice.
4338382/03 EN - VACUTAP[®] VM[®] Installation and commissioning instructions -
F0387902 - 06/23
Maschinenfabrik Reinhausen GmbH 2023

THE POWER BEHIND POWER.